

BOARD OF SELECTMEN AGENDA

MONDAY, December 18, 2017

SELECTMEN MEETING 7:00 P.M.

SELECTMEN'S CONFERENCE ROOM TOWN OFFICES

REGULAR MEETING – BOARD OF SELECTMEN – Selectmen Conference Room

- I. Call to Order– 7:00 P.M.
- II. Opening Ceremonies – 7:00 P.M.
 - A. Moment of Silence/Pledge of Allegiance
- III. Communications/Announcements/Liaison Reports – 7:05 P.M.
- IV. Citizens Petitions and Presentations – 7:10 P.M.
- V. Public Hearing – 7:15 P.M.
 - A. Mobilitie, LLC – (10 minutes)

Hearing is being held on the petition of Mobilitie, LLC for permission to attach small cell backhaul equipment to an existing pole located at the Enmore Street and MA Route 133, Haverhill Street, intersection. The existing pole is owned by National Grid.
- VI. Regular Business of the Board – 7:25 P.M.
 - A. Vaping Presentation – (10 minutes)

The Health Director and Healthy Communities Tobacco Awareness Program Director will present information to the Board on Vaping.
 - B. Signing Warrant for Special Town Meeting – (5 minutes)

Board to consider to vote to sign the Special Town Meeting Warrant.
 - C. FY2019 – FY2023 Capital Improvement Program – (15 minutes)

Board to consider to vote to accept the Town of Andover's FY2019 – FY2023 CIP.
 - D. Update on the Dascomb Road Project – (10 minutes)

Lupoli Companies will give the Board an update on the Dascomb Road Project.
 - E. Gift of Funds – (10 minutes)

Board to consider voting to accept a gift of \$20,000 from the Lupoli Companies for the purpose of funding peer reviews and studies deemed necessary by the Dascomb Road Task Force.
 - F. Andover Community Access and Media, Inc. – (5 minutes)

Board to consider to vote to sign the renewal agreement with Andover Community Access and Media, Inc.
 - G. New Meeting Dates – (5 minutes)

Board to consider to vote on the following meeting dates: January 8th, 22nd 2018, February 5th, 26th 2018, March 12th, 26th 2018 and April 9th, 23rd 2018.

VII. Consent Agenda – 8:25 P.M.

A. APPOINTMENTS – (Town Manager)

That the following appointments by the Town Manager be approved:

DEPARTMENT/ COMMITTEE	NAME	POSITION	RATE/ TERM	DOH
Facilities Dept.	Robert Rafferty (v. J. Sgross)	Temp. Carpenter 2 nd Shift	\$58,109	12/19/17
Municipal Services	Jason Walsh	Season Laborer Temp.	\$11.00/hr.	12/19/17
Recreation Services	Felicia Lazarakis	Group Leader	\$16.00/hr.	11/27/17
Recreation Services	Daniel McCarthy	Basketball Coach	\$11.00/hr.	12/02/17
Youth Services	Gregory Poelker- McKee	AYS Counselor 2	\$11.00/hr.	11/20/17
Youth Services	Jesse Ford	AYS Counselor 2	\$11.00/hr.	11/27/17
Youth Services	Samantha Sylvester	AYS Counselor 2	\$11.00/hr.	11/20/17

VIII. Approval of Minutes from Previous Board of Selectmen Meetings - 8:30 P.M
November 13, 2017 (Regular Meeting)

IX. Adjournment – 8:35 P.M.

If any member of the public wishing to attend this meeting seeks special accommodations in accordance with the Americans with Disabilities Act, please contact Wendy Adams at 978-623-8210 or wadams@andoverma.gov in the Town Manager's Office.



TOWN OF ANDOVER

Town Clerk's Office

36 Bartlet Street
Andover, MA 01810
978-623-8230
townclerk@andoverma.gov

NOTICE

You are hereby notified that a Public Hearing will be held by the Andover Board of Selectmen at the Town Offices on Bartlet Street, in the third floor Selectmen's Conference Room on Monday, December 18, 2017 at 7:00 P.M.

This hearing is being held on the petition of Mobilitie, LLC for permission to attach small cell backhaul equipment to an existing pole located at the **Enmore Street and MA Route 133, Haverhill Street**, intersection. The existing pole is owned by National Grid.

Plan(s) of the proposed work can be found in the Meeting Packet on the Board of Selectmen page on the Town of Andover website, www.andoverma.gov.

Should you have any major concerns about this proposal, please contact Mobilitie LLC representative Eric Kallio by email at EKallio@mobilitie.com or phone at 978-808-8258 prior to the above-mentioned Selectmen's meeting date. Representatives from Mobilitie LLC will also be available at 6:45 P.M. on the above date to answer any questions you may have relating to the proposed work.

If you have questions about this notice please contact the Town Manager's office by email to manager@andoverma.gov or phone 978-623-8225.

By order of the
Board of Selectmen

Lawrence J. Murphy
Town Clerk

Plan No.: BS90XSC47F
Date: December 8, 2017



September 18, 2017

Board of Selectmen
Town of Andover Massachusetts
36 Bartlet Street
Andover, MA 01810

RE: Utility Petition Application to Attach Small Cell Backhaul Equipment to Existing Utility Pole

Applicant: Mobilitie LLC (“Mobilitie”)
Location: Enmore Street and MA-133 Haverhill Street, Andover, MA (Candidate BS90XSC47F)
Authority: Town of Andover Board of Selectmen

Dear Chair Paul J. Salafia and members of the Board of Selectmen:

The purpose of this correspondence is to file Mobilitie’s enclosed application for a utility petition and order to attach small cell backhaul equipment to an existing utility pole that is located at the Enmore Street and MA-133 Haverhill Street intersection and is owned by National Grid.

APPLICANT INFORMATION

For over 11 years, Mobilitie has deployed a variety of signal strengthening services across the nation. Mobilitie is the nation’s largest privately held wireless infrastructure company. In Massachusetts, Mobilitie is registered as a Competitive Local Exchange Carrier (“CLEC”), which is regulated by the Department of Telecommunications and Cable. As provided in this registration, Mobilitie may provide transport, backhaul, broadband, voice, data as well as other infrastructure used by carriers, emergency responders, public safety agencies, backhaul providers and other companies.

Mobilitie is currently in the process of rolling out a Hybrid Transport Network (HTN) to more effectively deploy low cost, high-bandwidth connectivity throughout urban, suburban and rural communities. This HTN will provide backhaul connectivity solutions for customers. Mobilitie will provide a method to connect devices back to a core network (i.e. existing locations), through these small cell locations, where data is processed and routed. Due to the increased demand for data in certain areas, existing locations require enhanced support to provide customers with more reliable service. Small cells are the future for communities that seek non-obtrusive and concealed ways to increase coverage and capacity for its residents. Small cell deployment is essential for the Internet of Things and 5G. The addition of small cells to existing wireless networks will help responders more accurately located wireless 911 calls leading to significant E911 readiness and first responder improvements.

Our primary customer is Sprint. Mobilitie’s network, however, can support a variety of technologies and services that require connectivity to the internet, including but not limited to, driverless and connected vehicles (commercial, personal and agricultural), remote weather stations and other mobile service providers. Mobilitie’s small cell sites involve the installation of a small, low-powered transmit/receive antenna that communicates with

wireless devices, a wireless backhaul antenna that connects the facility to the carrier's core network and compact radio equipment mounted on either new or existing utility light poles. This proposed Sprint small cell location will add capacity to the existing wireless network in Andover and is designed to blend with existing infrastructure.

PROJECT NARRATIVE

Mobilitie's equipment, including its antennas and supporting MMS boxes, have been designed to avoid aesthetic impact on residents and compliment the overall community. Mobilitie has developed a host of structures to accommodate various community and local situations that include attachments to basic wooden telephone poles as well as stealth designed street light structures. As a company, Mobilitie is committed to meeting municipal design standards, while making sure residents have the highest quality connectivity to wireless communication. The site is designed and intended to provide additional data capacity and denser coverage in the city to satisfy the growing data service needs.

Summary of key points for the proposed installation:

<u>Location:</u>	Intersection of Enmore Street and MA-133 Haverhill Street
<u>Height of Existing Pole:</u>	30'
<u>Height of Existing Pole w/Proposed Equipment:</u>	33'
<u>Ownership:</u>	National Grid
<u>Status of Application:</u>	Site License in Progress

CLOSING REMARKS

In summary, the attached small cell backhaul equipment is necessary to support and enhance the existing Sprint locations in Andover to provide reliable data coverage for customers now and in the future. The need is driven by the exponential increase for wireless data services by Sprint customers in the proposed area.

To provide high quality service to consumers and support this demand as well as expected future demand with 5G, Mobilitie request that the Board of Selectmen grant the utility petition and order for this installation and any conditions as deemed necessary to allow this proposed installation in the Town of Andover.

Thank you for your consideration in this matter. If the Board of Selectmen should have any questions regarding this petition, please do not hesitate to contact me directly at 978-808-8258 or by email at EKallio@mobilitie.com.

Truly Yours,

Eric Kallio
Permitting Manager, New England
62A West Street
Swanzey, NH 03446

SITE ID-CANDIDATE LETTER/CASCADE ID-CANDIDATE LETTER:

9MAB001157F/BS90XSC47F

LATITUDE/LONGITUDE:

42.673605/-71.143467

CROSS STREET:

ENMORE ST & MA-133/HAVERHILL ST

CITY, STATE, ZIP:

ANDOVER, MA 01810



IF YOU DIG IN ANY STATE
DIAL 811 FOR THE LOCAL
"ONE CALL CENTER" -
IT'S THE LAW

THE UTILITIES SHOWN HEREIN ARE FOR THE CONTRACTORS
CONVENIENCE ONLY. THERE MAY BE OTHER UTILITIES NOT
SHOWN ON THESE PLANS. THE ENGINEER/SURVEYOR ASSUMES
NO RESPONSIBILITY FOR THE LOCATIONS SHOWN AND IT SHALL
BE THE CONTRACTOR'S RESPONSIBILITY TO VERIFY ALL THE
UTILITIES WITHIN THE LIMITS OF THE WORK. ALL DAMAGE MADE
TO THE (E) UTILITIES BY THE CONTRACTOR SHALL BE THE
SOLE RESPONSIBILITY OF THE CONTRACTOR.



3475 PIEDMONT ROAD NE
SUITE 1000
ATLANTA, GEORGIA 30305
PHONE: (312) 638-5400

PROJECT NO: ER600201
DRAWN BY: J. RECAÑA
CHECKED BY: C. O'DELL

PRELIM - NOT FOR CONSTRUCTION

08.21.17 PRELIM - NOT FOR CONSTRUCTION

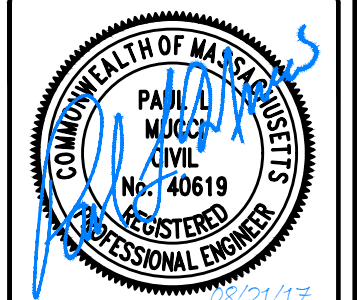

IT IS A VIOLATION OF THE LAW FOR ANY
PERSON, UNLESS THEY ARE ACTING UNDER THE
DIRECTION OF A LICENSED PROFESSIONAL
ENGINEER, TO ALTER THIS DOCUMENT

BS90XSC47F
9MAB001157F
ENMORE ST &
MA-133/HAVERHILL ST
ANDOVER, MA 01810
UTILITY POLE

SHEET TITLE
TITLE SHEET

SHEET NUMBER
T-1

GENERAL NOTES

THE FACILITY IS UNMANNED AND NOT FOR HUMAN HABITATION. A
TECHNICIAN WILL VISIT THE SITE AS REQUIRED FOR ROUTINE
MAINTENANCE. THE PROJECT WILL NOT RESULT IN ANY SIGNIFICANT
DISTURBANCE OF EFFECT ON DRAINAGE; NO SANITARY SEWER
SERVICE, POTABLE WATER OR TRASH DISPOSAL IS REQUIRED AND
NO COMMERCIAL SIGNAGE IS PROPOSED.

SITE INFORMATION

SITE ID:	9MAB001157F
CASCADE ID:	BS90XSC47F
LATITUDE:	42.673605
LONGITUDE:	-71.143467
CROSS STREET:	ENMORE ST & MA-133/HAVERHILL ST
CITY, STATE, ZIP:	ANDOVER, MA 01810
COUNTY:	ESSEX COUNTY
JURISDICTION:	TOWN OF ANDOVER
PROPERTY OWNER:	PUBLIC RIGHT-OF-WAY
APPLICANT:	MOBILITIE, LLC 3475 PIEDMONT ROAD NE; SUITE 1000 ATLANTA, GEORGIA 30305 PHONE: (312) 638-5400

ENGINEER

JACOBS ENGINEERING GROUP, INC. CONTACT: KARL KRATINA
5449 BELLS FERRY ROAD PROJECT MANAGER
ACWORTH, GA 30102 TEL: (678) 460-1416
PROJECT: ER600201

DO NOT SCALE DRAWINGS

CONTRACTORS SHALL VERIFY ALL PLANS, (E) DIMENSIONS & FIELD
CONDITIONS ON THE JOB SITE & SHALL IMMEDIATELY NOTIFY THE
ARCHITECT/ENGINEER IN WRITING OF ANY DISCREPANCIES BEFORE
PROCEEDING WITH THE WORK OR BE RESPONSIBLE FOR SAME.

LOCATION MAPS

VICINITY MAP

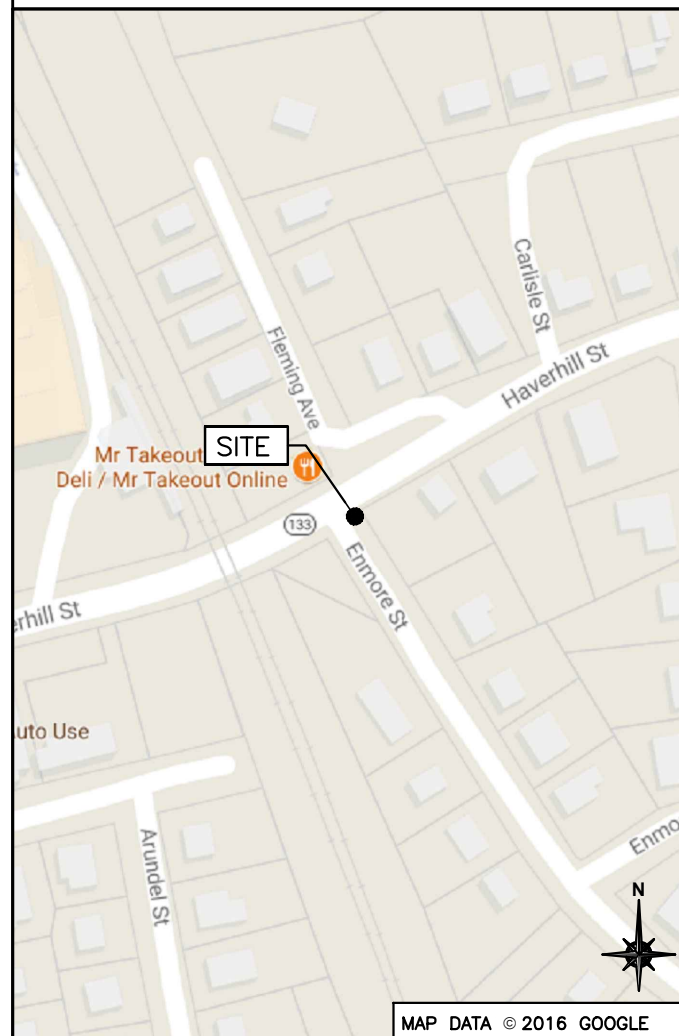

REGIONAL MAP



PROJECT DESCRIPTION

END USER PROPOSES TO INSTALL EQUIPMENT ON AN
EXISTING WOOD POLE WITHIN AN EXISTING RIGHT-OF-WAY.
THE SCOPE WILL CONSIST OF THE FOLLOWING:

- INSTALL PROPOSED BACKHAUL TRANSPORT EQUIPMENT ON
AN EXISTING WOOD UTILITY POLE

CODES

INTERNATIONAL BUILDING CODE
NATIONAL ELECTRICAL SAFETY CODE
TIA/EIA-222-G-2 OR LATEST EDITION
LOCAL BUILDING/PLANNING CODE

DRAWING INDEX

SHEET NO:	SHEET TITLE
T-1	TITLE SHEET
SP-1	EXHIBIT PHOTO & SITE PLAN
EV-1	POLE ELEVATIONS
EV-2	POLE ELEVATIONS
PL-1	PLUMBING & RISER DIAGRAM
EQ-1	EQUIPMENT DETAILS
EQ-2	EQUIPMENT DETAILS
EQ-3	EQUIPMENT DETAILS
EX-1	EXCAVATION DETAILS
E-1	ELECTRICAL DETAILS
G-1	GROUNDING DETAILS
TC-1	VEHICULAR TRAFFIC CONTROL PLAN
TC-2	PEDESTRIAN SAFETY PLAN
GN-1	GENERAL NOTES
GN-2	GENERAL NOTES
GN-3	GENERAL NOTES

MAP DATA © 2016 GOOGLE

MAP DATA © 2016 GOOGLE

ALL (N) EQUIPMENT INSTALLATIONS SHALL COMPLY WITH NATIONAL GRID REQUIREMENTS

mobilitie
Intelligent Infrastructure

3475 PIEDMONT ROAD NE
SUITE 1000
ATLANTA, GEORGIA 30305
PHONE: (312) 638-5400

PROJECT NO: ER600201
DRAWN BY: J. RECAÑA
CHECKED BY: C. O'DELL

PRELIM - NOT FOR CONSTRUCTION

A 08.21.17 PRELIM - NOT FOR CONSTRUCTION

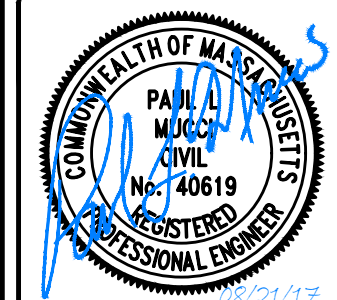

IT IS A VIOLATION OF THE LAW FOR ANY PERSON, UNLESS THEY ARE ACTING UNDER THE DIRECTION OF A LICENSED PROFESSIONAL ENGINEER, TO ALTER THIS DOCUMENT

BS90XSC47F
9MAB001157F
ENMORE ST &
MA-133/HAVERHILL ST
ANDOVER, MA 01810
UTILITY POLE

SHEET TITLE

POLE ELEVATIONS

SHEET NUMBER

EV-1

NOTE:
PROPOSED EQUIPMENT SHALL BE INSTALLED NO HIGHER THAN 30" BELOW BELOW TELEPHONE UTILITY LINES

ANTENNAS SHALL NOT BE INSTALLED ON POLES WITH AIRBREAK OR LOADBREAK SWITCHES, LINE RECLOSERS, SECTIONALIZERS, CAPACITORS, VOLTAGE REGULATOR, TRANSFORMERS, PRIMARY OR SECONDARY RISERS, MAJOR COMMUNICATIONS OR FIRE ALARM EQUIPMENT, OTHER ANTENNAS, THREE OR FOUR-WAY PRIMARY JUNCTION POLES AND BACKYARD POLES.

NOTE:
PROJECT SCOPE OF WORK DOES NOT INCLUDE A STRUCTURAL EVALUATION OF THIS POLE OR STRUCTURE. NEW EQUIPMENT SHOWN ON THIS PLAN HAVE NOT BEEN EVALUATED TO VERIFY THE POLE OR STRUCTURE HAS THE CAPACITY TO ADEQUATELY SUPPORT THE EQUIPMENT. PRIOR TO ANY INSTALLATION, A STRUCTURAL EVALUATION OF THE POLE OR STRUCTURE SHOULD BE PERFORMED.

(E) CLASS 3 OR CLASS 4 WOOD POLE

EXISTING SIDE VIEW

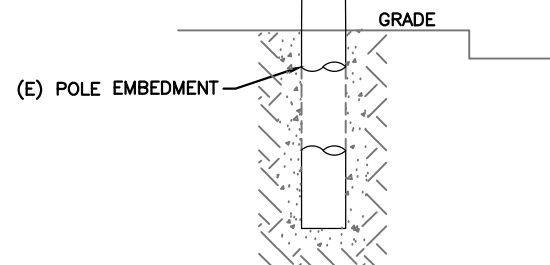

(N) OMNI-DIRECTIONAL ANTENNA TO BE INSTALLED WITH 3/8" THROUGH BOLT

(N) 2" PVC MIN. STRAPPED TO POLE AT 30" INTERVALS

(E) STREET LIGHT

(E) SECONDARY POWER (TYP.)

(E) COMMUNICATION LINES (TYP.)

(N) UE RELAY ATTACHED WITH 3/8" THROUGH BOLT

(N) RF FILTER ATTACHED WITH 3/8" THROUGH BOLT

(E) SIGN

(N) GPS UNIT MOUNTED TO RADIO

(N) RADIO ATTACHED WITH 3/8" THROUGH BOLT

(N) AC POWER DISTRIBUTION PANEL ATTACHED WITH 3/8" THROUGH BOLT

(N) 100A METER ATTACHED WITH 3/8" THROUGH BOLT

(N) DISCONNECT ATTACHED WITH 3/8" THROUGH BOLT

(E) CLASS 3 OR CLASS 4 WOOD POLE

(N) POWER CONDUIT & WIRE PER CODE. SIZE TBD

(1) (N) 2" RIGID CONDUIT FOR POWER TO BE INSTALLED BY POWER COMPANY

NOTES:

1. ALL HARDWARE SHALL BE STAINLESS STEEL.
2. ALL CABLES SHALL BE SECURED TO POLE EVERY 36" OR LESS.
3. LIGHTNING RODS SHALL BE INCLUDED AS REQUIRED.

T/ OF (N) ANTENNA = ± 33'-4"

☐ OF (N) ANTENNA = ± 32'-1"

B/ OF (N) ANTENNA = ± 30'-10"

T/ OF (E) POLE = ± 30'-0"

☐ OF (N) UE RELAY = ±17'-6"

B/ OF (N) UE RELAY = ±17'-0"

☐ OF (N) RF FILTER = ±16'-0"

☐ OF (N) RADIO HEAD = ±13'-9"

☐ OF (N) AC DISTRIBUTION BOX = ±11'-11"

☐ OF (N) METER = ±10'-4"

B/ OF (N) DISCONNECT = ±8'-0"

NEW SIDE VIEW

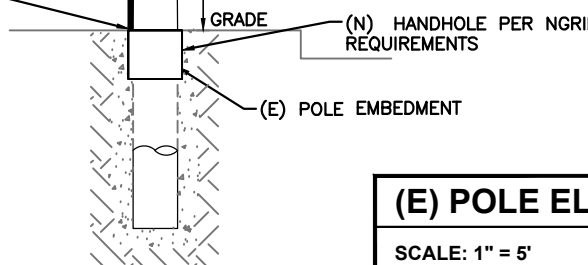

(E) POLE ELEVATIONS

SCALE: 1" = 5'

1

PREFERRED RISER QUADRANTS NOT TO SCALE

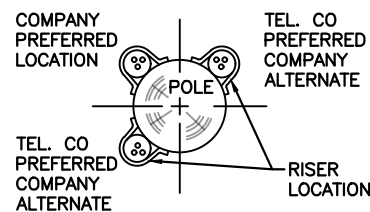

CURB

STREET ← TRAFFIC FLOW

ALL (N) EQUIPMENT INSTALLATIONS SHALL COMPLY WITH NATIONAL GRID REQUIREMENTS

mobilitie
Intelligent Infrastructure

3475 PIEDMONT ROAD NE
SUITE 1000
ATLANTA, GEORGIA 30305
PHONE: (312) 638-5400

NOTE:
PROPOSED EQUIPMENT SHALL BE INSTALLED NO HIGHER THAN 30" BELOW BELOW TELEPHONE UTILITY LINES

ANTENNAS SHALL NOT BE INSTALLED ON POLES WITH AIRBREAK OR LOADBREAK SWITCHES, LINE RECLOSERS, SECTIONALIZERS, CAPACITORS, VOLTAGE REGULATOR, TRANSFORMERS, PRIMARY OR SECONDARY RISERS, MAJOR COMMUNICATIONS OR FIRE ALARM EQUIPMENT, OTHER ANTENNAS, THREE OR FOUR-WAY PRIMARY JUNCTION POLES AND BACKYARD POLES.

NOTE:
PROJECT SCOPE OF WORK DOES NOT INCLUDE A STRUCTURAL EVALUATION OF THIS POLE OR STRUCTURE. NEW EQUIPMENT SHOWN ON THIS PLAN HAVE NOT BEEN EVALUATED TO VERIFY THE POLE OR STRUCTURE HAS THE CAPACITY TO ADEQUATELY SUPPORT THE EQUIPMENT. PRIOR TO ANY INSTALLATION, A STRUCTURAL EVALUATION OF THE POLE OR STRUCTURE SHOULD BE PERFORMED.

(E) CLASS 3 OR CLASS 4 WOOD POLE

(N) OMNI-DIRECTIONAL ANTENNA TO BE INSTALLED WITH 3/8" THROUGH BOLT

(N) 2" PVC MIN. STRAPPED TO POLE AT 30" INTERVALS

(E) STREET LIGHT

(E) SECONDARY POWER (TYP.)

(E) COMMUNICATION LINES (TYP.)

(E) EQUIPMENT

(N) UE RELAY ATTACHED WITH 3/8" THROUGH BOLT

(N) RF FILTER ATTACHED WITH 3/8" THROUGH BOLT

(N) GPS UNIT MOUNTED TO RADIO

(N) RADIO ATTACHED WITH 3/8" THROUGH BOLT

(N) AC POWER DISTRIBUTION PANEL ATTACHED WITH 3/8" THROUGH BOLT

(E) SIGN

(N) 100A METER ATTACHED WITH 3/8" THROUGH BOLT

(N) DISCONNECT ATTACHED WITH 3/8" THROUGH BOLT

(E) CLASS 3 OR CLASS 4 WOOD POLE

(N) POWER CONDUIT & WIRE PER CODE. SIZE TBD

(1) (N) 2" RIGID CONDUIT FOR POWER TO BE INSTALLED BY POWER COMPANY

NOTES:

1. ALL HARDWARE SHALL BE STAINLESS STEEL.
2. ALL CABLES SHALL BE SECURED TO POLE EVERY 36" OR LESS.
3. LIGHTNING RODS SHALL BE INCLUDED AS REQUIRED.

T/ OF (N) ANTENNA = ± 33'-4"

℄ OF (N) ANTENNA = ± 32'-1"

B/ OF (N) ANTENNA = ± 30'-10"

T/ OF (E) POLE = ± 30'-0"

℄ OF (N) UE RELAY = ±17'-6"

B/ OF (N) UE RELAY = ±17'-0"

℄ OF (N) RF FILTER = ±16'-0"

℄ OF (N) RADIO HEAD = ±13'-9"

℄ OF (N) AC DISTRIBUTION BOX = ±11'-11"

℄ OF (N) METER = ±10'-4"

B/ OF (N) DISCONNECT = ±8'-0"

8' MIN./9' MAX
2'

NEW BACK VIEW

(N) HANDHOLE PER NGRD REQUIREMENTS

(E) POLE EMBEDMENT

EXISTING BACK VIEW

(E) POLE EMBEDMENT

GRADE

PREFERRED RISER QUADRANTS NOT TO SCALE

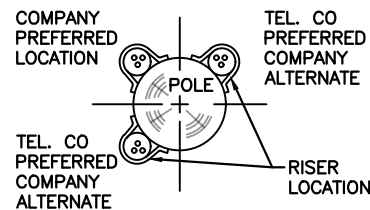

STREET ← TRAFFIC FLOW

(E) POLE ELEVATIONS

SCALE: 1" = 5'

1

PROJECT NO: ER600201
DRAWN BY: J. RECAÑA
CHECKED BY: C. O'DELL

PRELIM - NOT FOR CONSTRUCTION

08.21.17 PRELIM - NOT FOR CONSTRUCTION

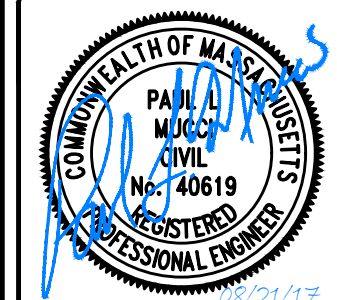

IT IS A VIOLATION OF THE LAW FOR ANY PERSON, UNLESS THEY ARE ACTING UNDER THE DIRECTION OF A LICENSED PROFESSIONAL ENGINEER, TO ALTER THIS DOCUMENT

BS90XSC47F
9MAB001157F
ENMORE ST &
MA-133/HAVERHILL ST
ANDOVER, MA 01810
UTILITY POLE

SHEET TITLE
POLE ELEVATIONS

SHEET NUMBER
EV-2

NOTE:
(E) POLE MOUNTED EQUIPMENT
NOT SHOWN FOR CLARITY.

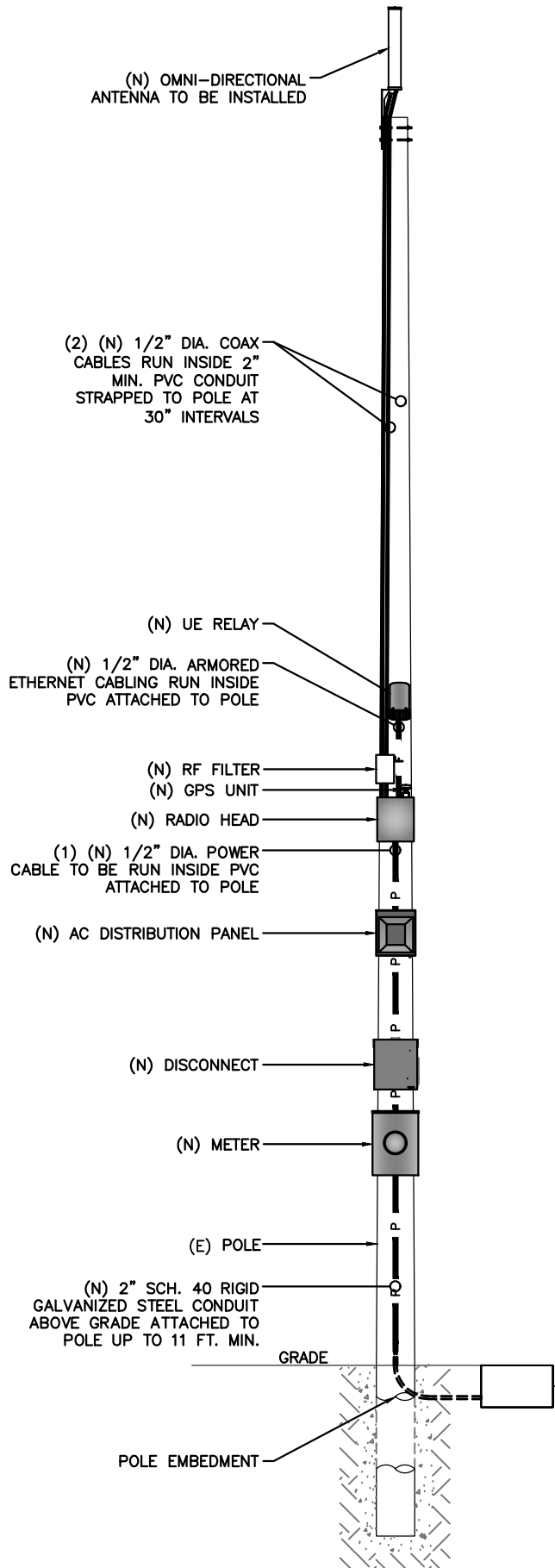

NOTE:
CABLING DIAGRAM IS FOR CLARITY OF
CABLE ROUTE AND TERMINATION ONLY.
CONTRACTOR SHALL INSTALL CABLES
WITH MINIMAL VISUAL IMPACT ON (E)
WOOD POLE. SEE ELEVATION DRAWING
FOR EQUIPMENT AND ANTENNA
LOCATIONS.

CABLING NOTES:

- A) WOOD, CONCRETE AND EXISTING METALLIC POLES
 - i) FROM GRADE LINE TO 11'-0" ABOVE GRADE, ALL CABLES/CONDUCTORS EXCEPT GROUNDING CONDUCTOR MUST RUN IN RIGID GALVANIZED STEEL CONDUIT (RGS)
 - ii) GROUNDING CONDUCTORS IN EXPOSED LOCATIONS MUST BE INSTALLED IN PVC.
 - iii) IN EARTH INSTALL PVC CONDUIT FOR BACKHAUL AND ELECTRICAL SERVICE. TRANSITION TO RGS AT GRADE LINE.
 - iv) ABOVE 11'-0" ALL CABLES (POWER, ETHERNET, COAXIAL) MUST RUN IN PVC UTILITY POLE RISER.
 - (1) AT MAJOR EQUIPMENT, EXTEND UTILITY DUCT IMMEDIATELY ADJACENT TO THE EQUIPMENT. INSTALL CABLES IN THE UTILITY POLE RISER CREATING CABLE DRIP LOOPS NOT LESS THAN THE CABLE BENDING RADIUS.
 - (2) INSIDE THE UTILITY POLE RISER, UTILIZE 1/2" COAX BLOCKS WITH LAG SCREWS TO SUPPORT COAX, RADIO AND MW POWER, RF COAX, AND ETHERNET CABLES TO WITHIN 12" OF THE EQUIPMENT BEING SERVED AND ON INTERVALS NOT TO EXCEED 4'.
 - v) FOR UNDERGROUND HFC/PUBLIC BACKHAUL, ROUTE ETHERNET CABLE IN CONDUIT UP THE POLE AND ENTER THE UTILITY POLE RISER. SEAL EXPOSED END OF CONDUIT WITH A CABLE TERMINATION FITTING.
 - vi) BY APPROVAL IN SELECT CASES LIQUID-TIGHT FLEXIBLE METALLIC CONDUIT (LFMC) MAY BE USED IN LENGTHS NOT TO EXCEED 36" TO EXTEND THE ELECTRICAL SERVICE CONDUIT TO THE AC DISTRIBUTION BOX. EXAMPLE: UTILITY-REQUIRED DISCONNECT ON POLE W/ AC DISTRIBUTION BOX ON OPPOSITE SIDE OF POLE. NOT REQUIRED FOR COAX.
- B) NEW METALLIC POLES
 - i) PROCURE NEW POLES WITH SUITABLE HAND HOLES SUCH THAT HAND HOLES EXIST AT ALL EQUIPMENT LOCATIONS.
 - ii) WHERE REQUIRED, INSTALL POLE BASE SUCH THAT THE ELECTRICAL FEED AND BACKHAUL (IF UNDERGROUND) CIRCUIT ENTER THE POLE THROUGH THE POLE BASE.

PLUMBING DIAGRAM

SCALE: NOT TO SCALE

1

BILL OF MATERIALS							
QTY.	DESCRIPTION	MANUFACTURER	MODEL NUMBER	AZIMUTH	CABLE	DIMENSIONS (HxWxD)	WEIGHT
1	ANTENNA	ALPHA WIRELESS	AW3477-S	TBD	18'±	30.7" X 4.7" DIAMETER	7 LBS
1	UE RELAY	AIRSPAN	iR460-SPB-ST-1-P-0	TBD	3'±	13" X 7" DIAMETER	8.8 LBS
-	-	-	-	-	-	-	-
1	GPS	NOKIA	FAWD/472932A	-	-	3.1" X 2.1" DIAMETER	0.3 LBS
1	RADIO	NOKIA	FWHR B41 HP	-	3'±	9.7" X 12.9" X 6.3"	24.7 LBS
1	RF REJECT FILTER	RFS	FIMM1963S-1C	-	-	12.8" X 4.8" X 2.8"	5.7 LBS
1	AC DISTRIBUTION PANEL	RAYCAP	RSTAC-3112-P-120	-	1'±	9.25" X 9.5" X 3.81"	14 LBS
1	NEMA TYPE-3R DISCONNECT	SIEMENS	GF222NR (EXAMPLE)	-	1'±	15.45" X 8.7" X 5.95"	14 LBS
1	METER SOCKET	MILBANK	U4801-XL-5T9 (EXAMPLE)	-	70'±	19" X 13" X 4.84"	21 LBS

RFDS REVISION TYPE: NOT FINAL
RFDS REVISION NUMBER: N/A
RFDS REVISION TIMESTAMP: N/A

BILL OF MATERIALS

SCALE: NOT TO SCALE

2

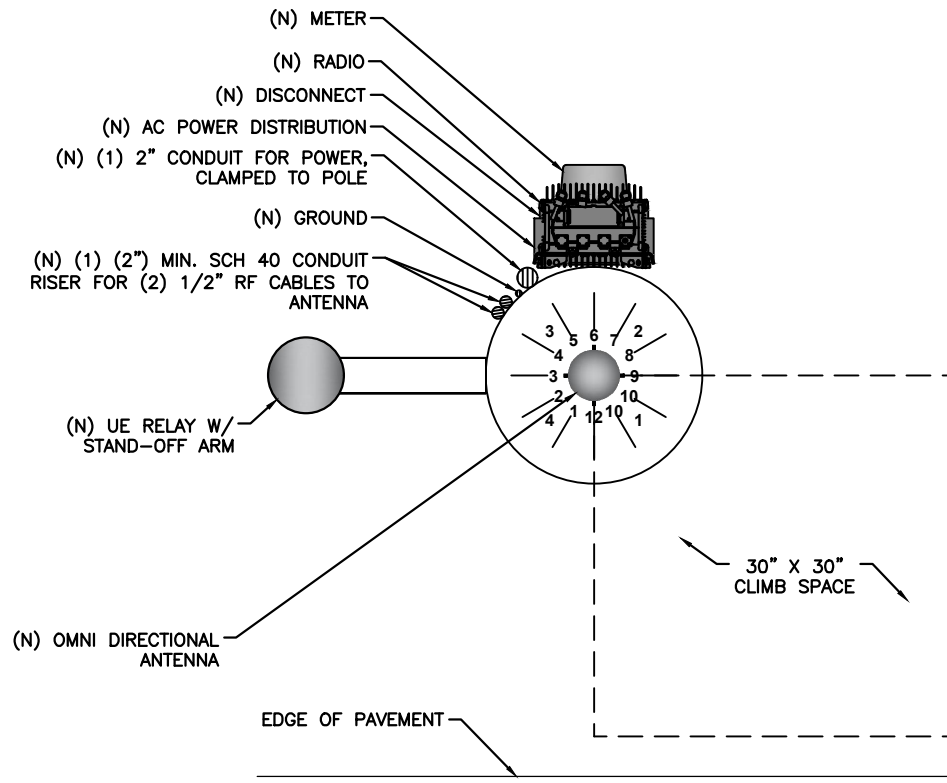

RISER ORIENTATION DIAGRAM

SCALE: NOT TO SCALE

3

mobilitie
Intelligent Infrastructure
3475 PIEDMONT ROAD NE
SUITE 1000
ATLANTA, GEORGIA 30305
PHONE: (312) 638-5400

PROJECT NO: ER600201
DRAWN BY: J. RECAÑA
CHECKED BY: C. O'DELL

PRELIM - NOT FOR CONSTRUCTION

08.21.17 PRELIM - NOT FOR CONSTRUCTION



IT IS A VIOLATION OF THE LAW FOR ANY PERSON, UNLESS THEY ARE ACTING UNDER THE DIRECTION OF A LICENSED PROFESSIONAL ENGINEER, TO ALTER THIS DOCUMENT

BS90XSC47F
9MAB001157F
ENMORE ST &
MA-133/HAVERHILL ST
ANDOVER, MA 01810
UTILITY POLE

SHEET TITLE
PLUMBING & RISER DIAGRAM

SHEET NUMBER
PL-1

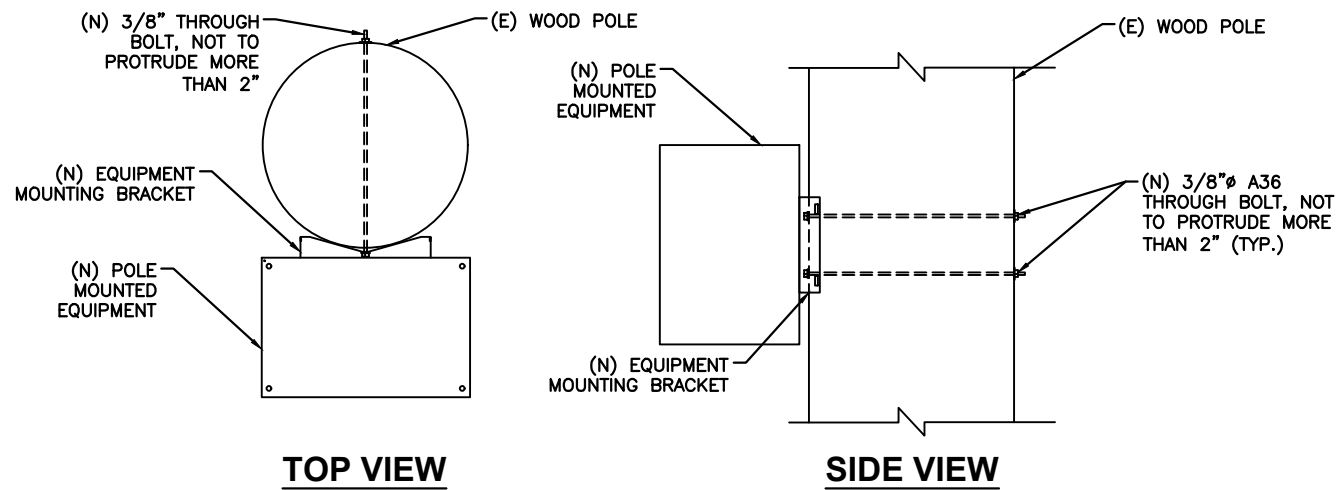

EQUIPMENT MOUNTING DETAIL
SCALE: NOT TO SCALE **1**

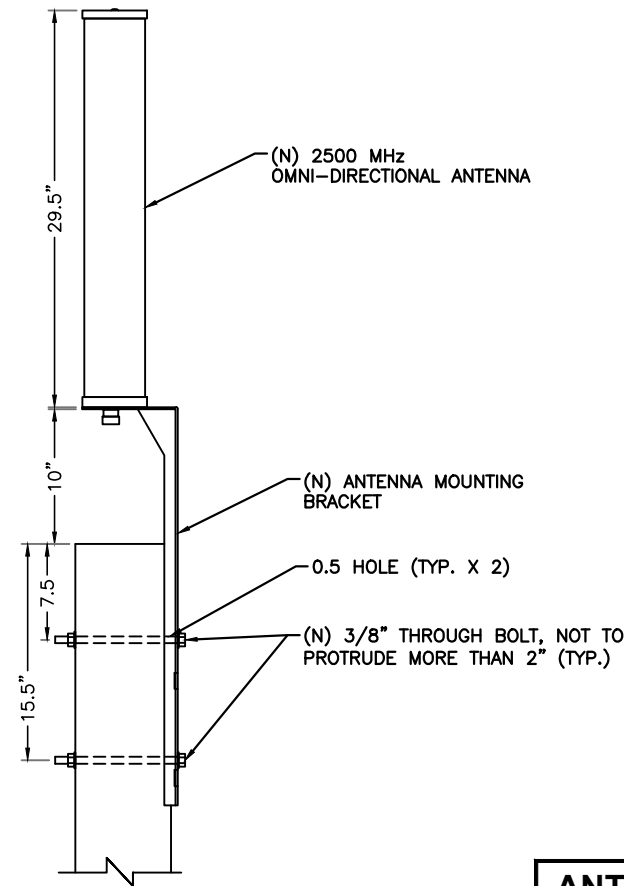

NOTE:
1. MOUNTING BRACKET ACCOMMODATES POLE SIZES FROM 3" TO 10" DIAMETER.
2. JACOBS HAS NOT PERFORMED A STRUCTURAL EVALUATION FOR THE MOUNTING BRACKET. REFER TO THE MANUFACTURER FOR ADDITIONAL INFORMATION.

ALL (N) EQUIPMENT INSTALLATIONS SHALL COMPLY WITH NATIONAL GRID REQUIREMENTS

ANTENNA MOUNTING DETAIL
SCALE: NOT TO SCALE **3**

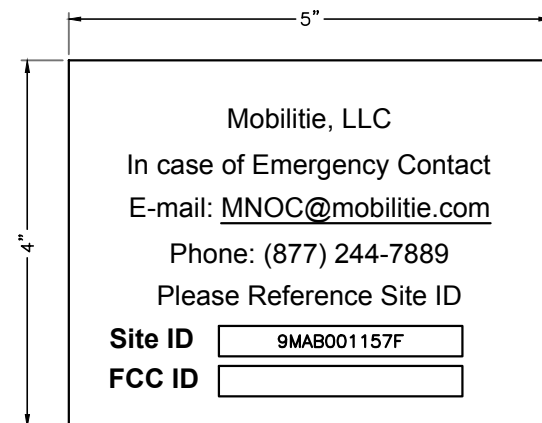
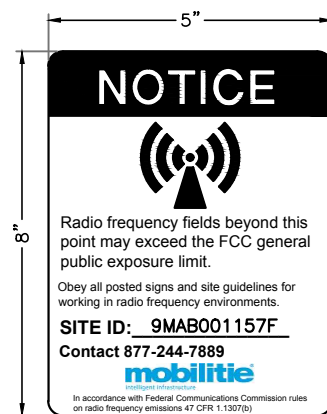

ANTENNA SIGNAGE:
ON WOOD POLES – SIGN ON ALUMINUM WITH SS SCREW TO THE POLE
ON METAL POLES – ADHESIVE VINYL OR PLACARD STRAPPED WITH SS TIES
ON CONCRETE / COMPOSITE – PLACARD STRAPPED WITH SS TIES
SIGN PLACEMENT:
AFFIX TO THE STRUCTURE 3–4' BELOW THE COMMERCIAL RF ANTENNA(S)
SIZE APPROX. 8" x 5"

OWNER / OPERATOR NOTE:
SITE ID LABEL TO BE AFFIXED AT OR NEAR THE POINT OF POWER CONNECTION WITH TZeS241 LABELING TAPE OR EQUIVALENT BLACK ON WHITE LABELING TAPE OF AT LEAST 18mm WIDTH WITH EXTRA-STRENGTH ADHESIVE. USE ANY COMPATIBLE P-TOUCH LABEL MAKER. TEXT SHOULD BE PRINTED IN ALL CAPS WITH A MINIMUM HEIGHT OF 1/2".

EMERGENCY CONTACT SIGN

ANTENNA SIGNAGE

POLE MOUNTED SIGNS
SCALE: NOT TO SCALE **2**

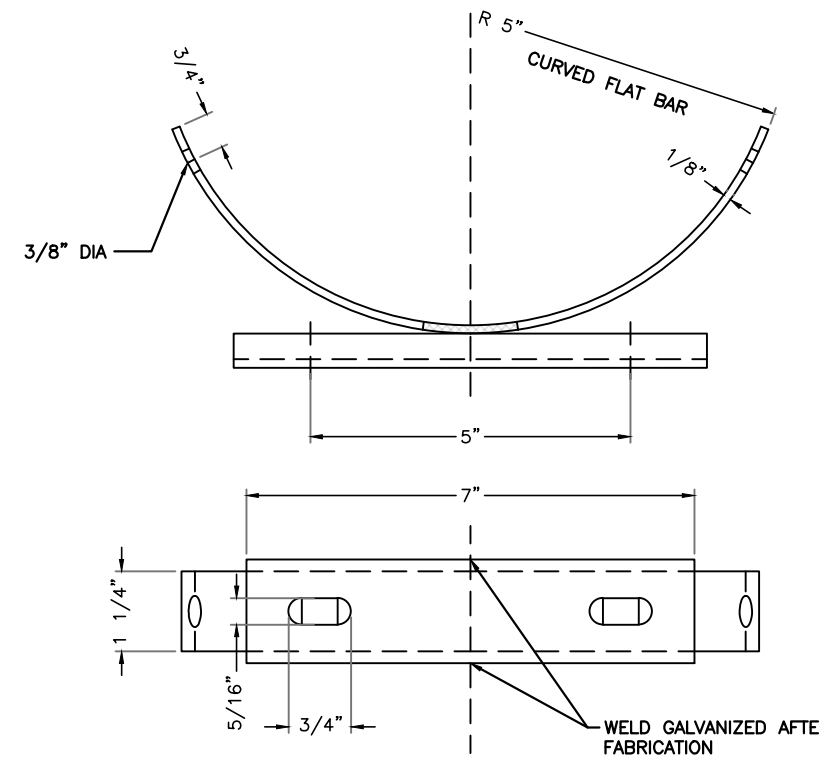

NOTE:
ATTACH THE BRACKET TO THE POLE WITH GALVANIZED LAG SCREWS AND THE SOCKET TO THE BRACKET WITH STAINLESS STEEL BOLTS, NUTS AND LOCK WASHERS. FABRICATE AND INSTALL PER NATIONAL GRID STANDARDS

METER SOCKET BRACKET AND CONNECTIONS
SCALE: NOT TO SCALE **4**



3475 PIEDMONT ROAD NE
SUITE 1000
ATLANTA, GEORGIA 30305
PHONE: (312) 638-5400

PROJECT NO: ER600201
DRAWN BY: J. RECAÑA
CHECKED BY: C. O'DELL

PRELIM - NOT FOR CONSTRUCTION

A 08.21.17 PRELIM - NOT FOR CONSTRUCTION



IT IS A VIOLATION OF THE LAW FOR ANY PERSON, UNLESS THEY ARE ACTING UNDER THE DIRECTION OF A LICENSED PROFESSIONAL ENGINEER, TO ALTER THIS DOCUMENT

BS90XSC47F
9MAB001157F
ENMORE ST &
MA-133/HAVERHILL ST
ANDOVER, MA 01810
UTILITY POLE

SHEET TITLE
EQUIPMENT DETAILS

SHEET NUMBER
EQ-2

- NOTES:
 1. POLES COVERED BY THIS SPECIFICATION SHALL COMPLY WITH ANSI O5.1 LATEST EDITION.
 2. THROUGH HOLES ARE TO BE 11/16" DIAMETER, AND TO BE DRILLED PERPENDICULAR TO LONGITUDINAL POLE AXIS.

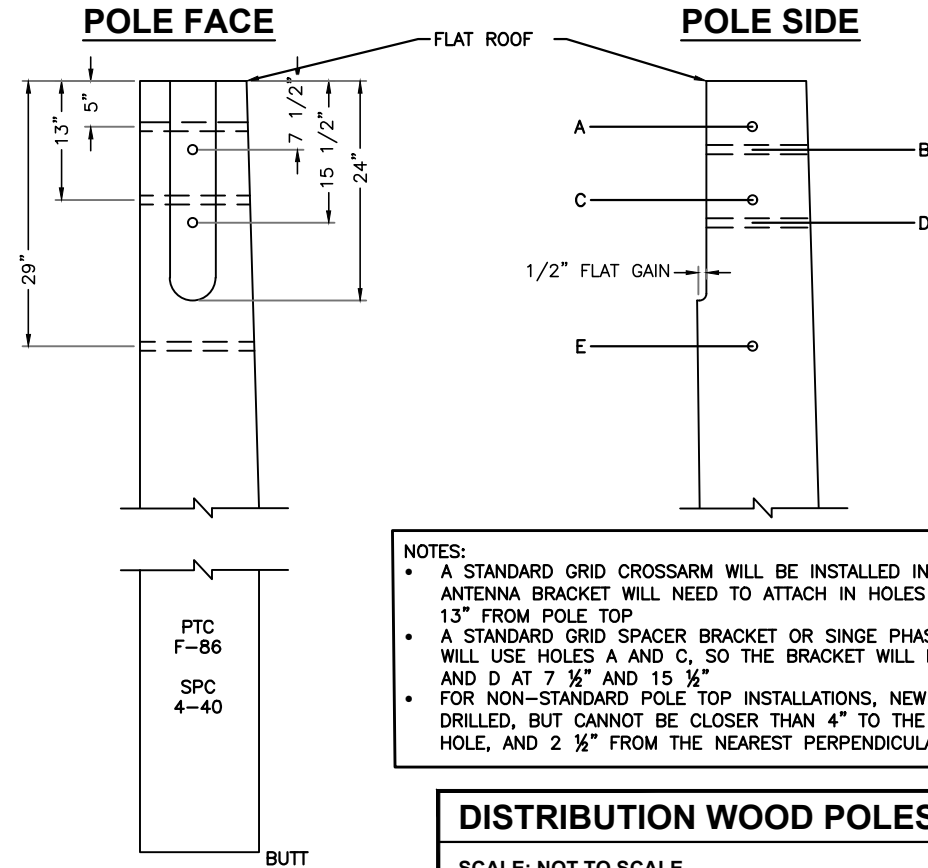

- NOTES:
- A STANDARD GRID CROSSARM WILL BE INSTALLED IN HOLE B, SO THE ANTENNA BRACKET WILL NEED TO ATTACH IN HOLES A AND C AT 5" AND 13" FROM POLE TOP
 - A STANDARD GRID SPACER BRACKET OR SINGLE PHASE SIDE ARM BRACKET WILL USE HOLES A AND C, SO THE BRACKET WILL NEED TO USE HOLES B AND D AT 7 1/2" AND 15 1/2"
 - FOR NON-STANDARD POLE TOP INSTALLATIONS, NEW HOLES MAY BE DRILLED, BUT CANNOT BE CLOSER THAN 4" TO THE NEAREST PARALLEL HOLE, AND 2 1/2" FROM THE NEAREST PERPENDICULAR HOLE

DISTRIBUTION WOOD POLES
 SCALE: NOT TO SCALE

1

*COMMUNICATIONS WORKER SAFETY ZONE

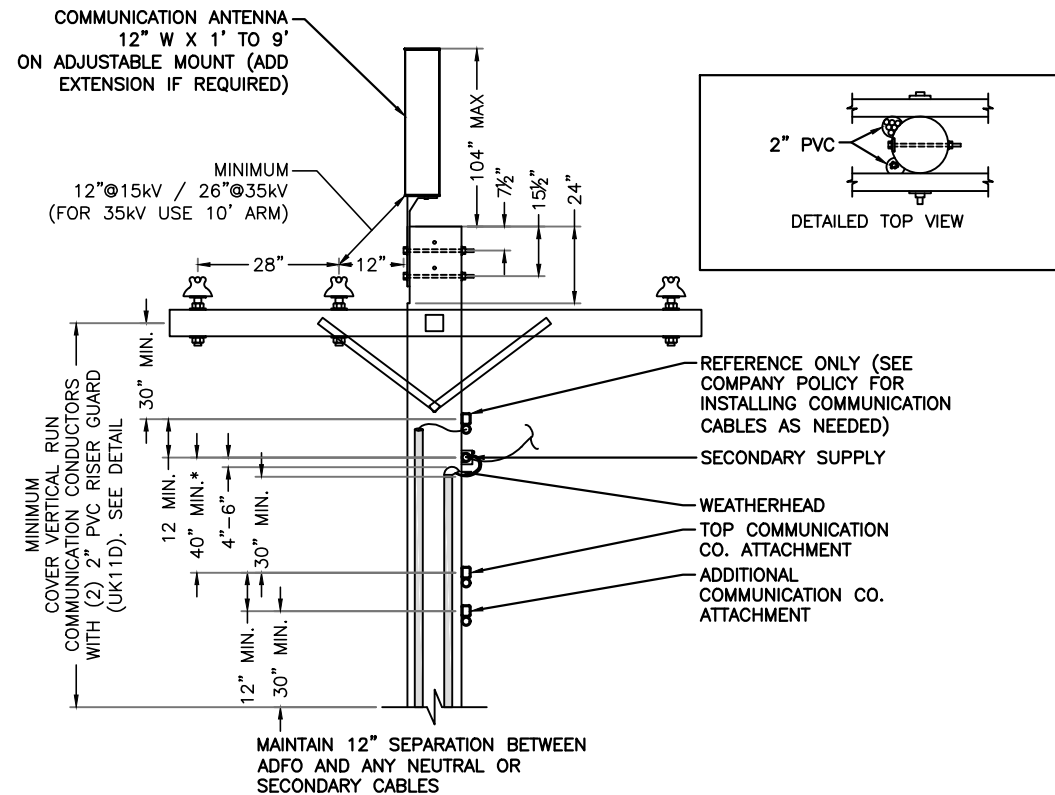

UTILITY CLEARANCE REQUIREMENTS
 SCALE: NOT TO SCALE

2

NOT USED
 SCALE: NOT TO SCALE

3



3475 PIEDMONT ROAD NE
 SUITE 1000
 ATLANTA, GEORGIA 30305
 PHONE: (312) 638-5400

PROJECT NO: ER600201
 DRAWN BY: J. RECAÑA
 CHECKED BY: C. O'DELL

PRELIM - NOT FOR CONSTRUCTION

A 08.21.17 PRELIM - NOT FOR CONSTRUCTION



IT IS A VIOLATION OF THE LAW FOR ANY PERSON, UNLESS THEY ARE ACTING UNDER THE DIRECTION OF A LICENSED PROFESSIONAL ENGINEER, TO ALTER THIS DOCUMENT

BS90XSC47F
 9MAB001157F
 ENMORE ST &
 MA-133/HAVERHILL ST
 ANDOVER, MA 01810
 UTILITY POLE

SHEET TITLE
EQUIPMENT DETAILS

SHEET NUMBER
EQ-3

PROJECT NO: ER600201
DRAWN BY: J. RECAÑA
CHECKED BY: C. O'DELL

PRELIM - NOT FOR CONSTRUCTION

A 08.21.17 PRELIM - NOT FOR CONSTRUCTION



IT IS A VIOLATION OF THE LAW FOR ANY PERSON, UNLESS THEY ARE ACTING UNDER THE DIRECTION OF A LICENSED PROFESSIONAL ENGINEER, TO ALTER THIS DOCUMENT

BS90XSC47F
9MAB001157F
ENMORE ST &
MA-133/HAVERHILL ST
ANDOVER, MA 01810
UTILITY POLE

SHEET TITLE
EXCAVATION DETAILS

SHEET NUMBER
EX-1

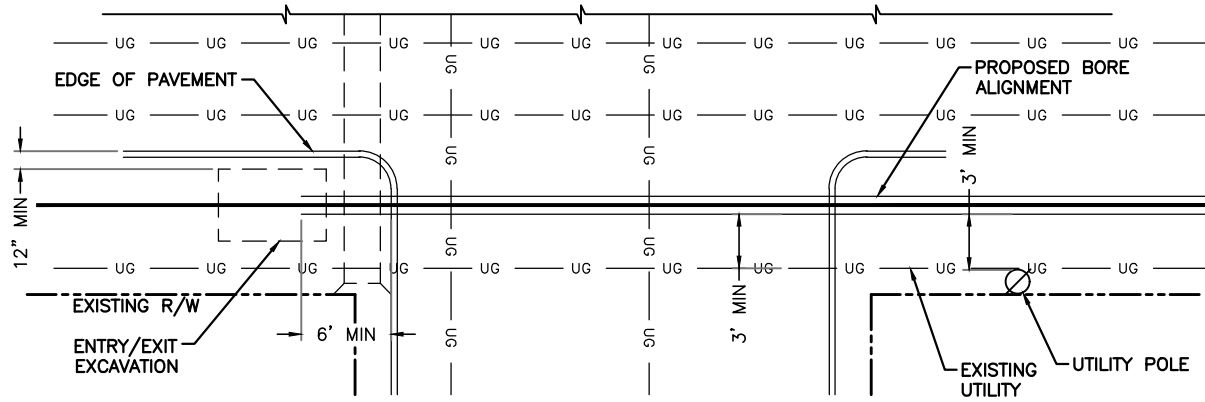

SUGGESTED HORIZONTAL MINIMUM CLEARANCES

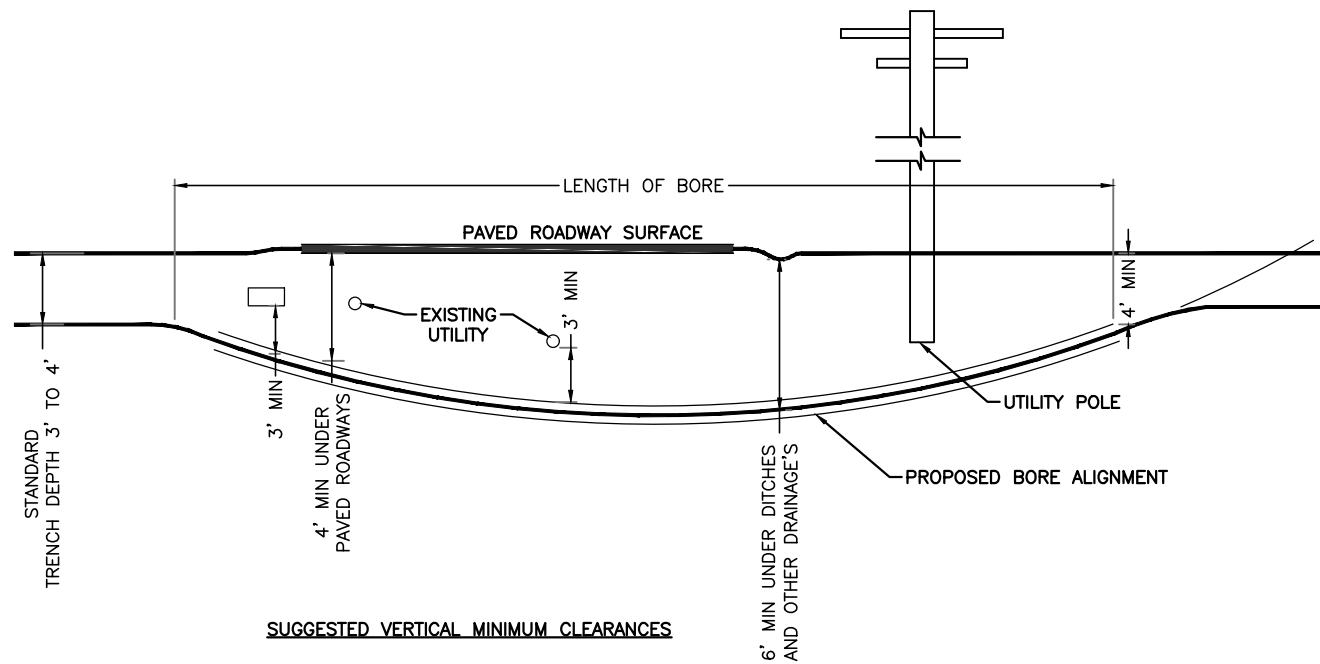

SUGGESTED VERTICAL MINIMUM CLEARANCES

DIRECTIONAL BORING DETAILS

SCALE: NOT TO SCALE

1

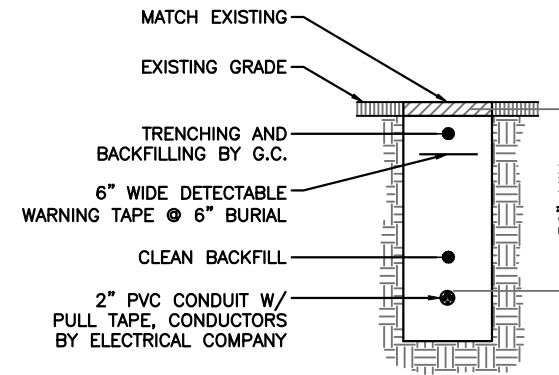

TRENCH SECTION DETAIL

SCALE: NOT TO SCALE

2

NOT USED

SCALE: NOT TO SCALE

3

PLAN NOTES:

1. PLANS DEPICTED ARE GENERAL GUIDELINES FOR TEMPORARY VEHICULAR TRAFFIC CONTROL PLANS (TCP) TO INCLUDE PEDESTRIAN AND WORKER SAFETY. CONTRACTOR IS REQUIRED TO HAVE PREPARED A SITE-SPECIFIC TCP FOR REVIEW AND APPROVAL BY THE HIGHWAY AUTHORITY HAVING JURISDICTION. IF REQUIRED, THE FIRM PREPARING THE TCP SHALL BE AUTHORIZED OR CERTIFIED BY THE AUTHORITY HAVING JURISDICTION.
2. EXTEND CHANNELIZATION DEVICES INTO SHOULDER WHERE APPLICABLE.
3. DISTANCES AS INDICATED IN TABLE 1 SHOULD BE INCREASED FOR CONDITIONS THAT WOULD AFFECT STOPPING. DISTANCE SUCH AS DOWNGRADES OR LIMITED SIGHT DISTANCES. DISTANCES CAN BE DECREASED FOR LOW-SPEED (RESIDENTIAL) AREAS WITH APPROVAL BY THE AUTHORITY HAVING JURISDICTION. NIGHT-TIME WORK IS PROHIBITED UNLESS IT IS REQUIRED AS A CONDITION OF APPROVAL BY THE HIGHWAY AND LOCAL AUTHORITY HAVING JURISDICTION.
4. SHOULDER TAPERS SHOULD BE 1/3 OF THE ON-STREET TAPER LENGTH.
5. MAINTAIN A MINIMUM LANE WIDTH OF 10'.

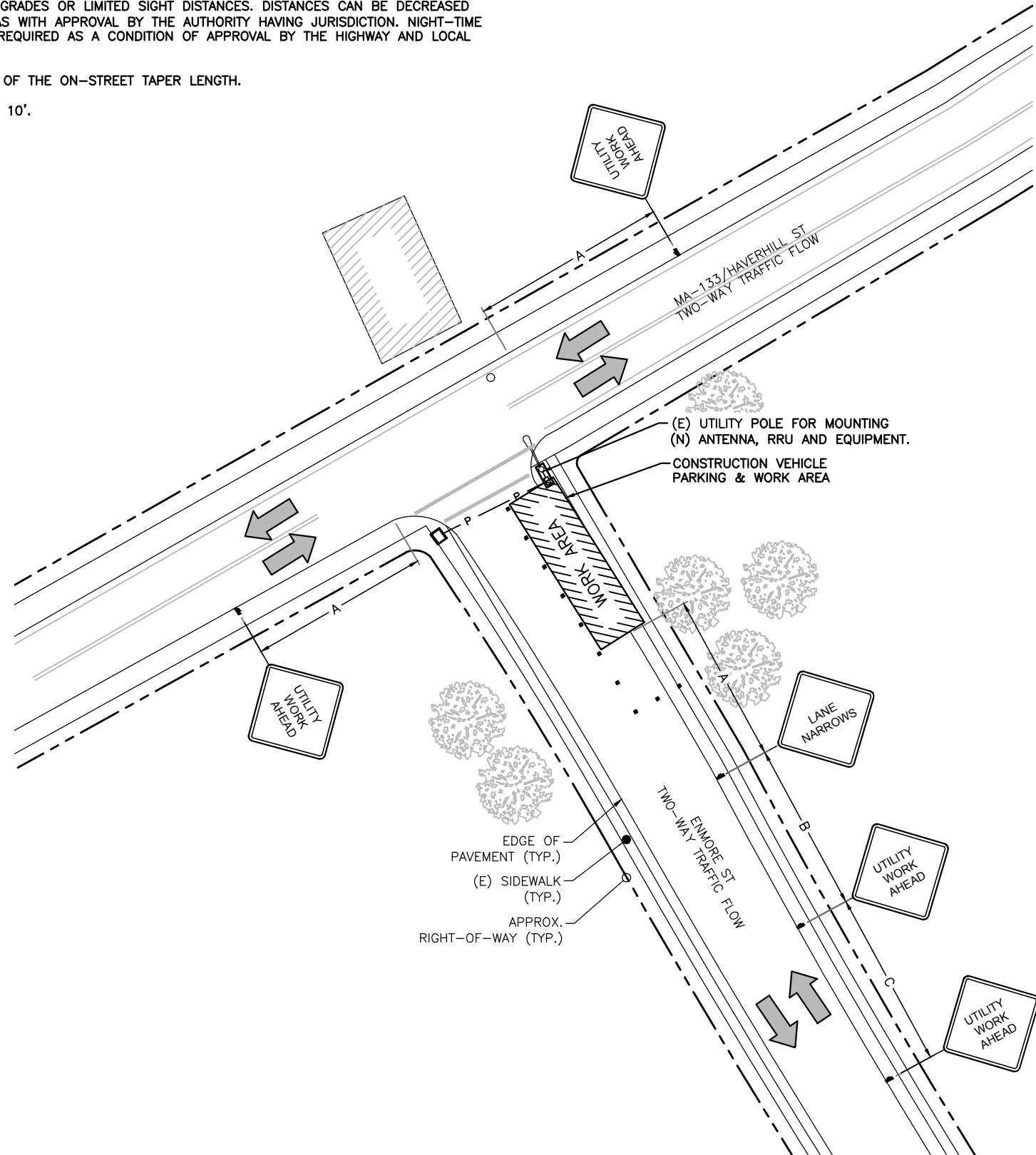

■ - SIGN

POSTED SPEED (MPH)	DISTANCE BETWEEN SIGNS			TAPER L (SEE NOTE)	BUFFER
	A	B	C		
15	100'	100'	100'	45'	100'
20	100'	100'	100'	80'	115'
25	100'	100'	100'	125'	155'
30	200'	200'	200'	180'	200'
35	200'	200'	200'	245'	250'
40	350'	350'	350'	320'	305'
45	350'	350'	350'	540'	360'
50	500'	500'	500'	600'	425'
55	500'	500'	500'	660'	495'
60	500'	500'	500'	720'	570'
65	500'	500'	500'	780'	645'

NOTES:
 A) DISTANCES IN FEET UNLESS OTHERWISE NOTED.
 B) CONTRACTOR TO VERIFY EXISTING SPEED LIMIT.
 C) DISTANCES SHOWN ARE NOT VALID FOR LIMITED ACCESS HIGHWAYS. CONSULT STATE DOT MANUAL FOR DISTANCES.
 D) ADJUST DISTANCES TO COMPLY WITH REQUIREMENT OF THE STATE OR LOCAL HIGHWAY AUTHORITY HAVING JURISDICTION. SEE NOTE 1, SHEET TC-2.
 E) TAPER LENGTHS SHOWN BASED ON 12' LANE WIDTH. SEE NOTE 18, SHEET TC-2.

VEHICULAR TRAFFIC CONTROL PLAN

SCALE: NOT TO SCALE

1



3475 PIEDMONT ROAD NE
 SUITE 1000
 ATLANTA, GEORGIA 30305
 PHONE: (312) 638-5400

PROJECT NO: ER600201
 DRAWN BY: J. RECAÑA
 CHECKED BY: C. O'DELL

PRELIM - NOT FOR CONSTRUCTION

A 08.21.17 PRELIM - NOT FOR CONSTRUCTION

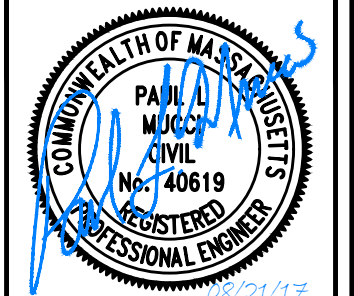

IT IS A VIOLATION OF THE LAW FOR ANY PERSON, UNLESS THEY ARE ACTING UNDER THE DIRECTION OF A LICENSED PROFESSIONAL ENGINEER, TO ALTER THIS DOCUMENT

BS90XSC47F
 9MAB001157F
 ENMORE ST &
 MA-133/HAVERHILL ST
 ANDOVER, MA 01810
 UTILITY POLE

SHEET TITLE
VEHICULAR TRAFFIC CONTROL PLAN

SHEET NUMBER

TC-1

TRAFFIC CONTROL GENERAL NOTES

1. ALL TEMPORARY TRAFFIC CONTROL SIGNAGE, LAYOUTS AND PROCEDURES SHALL COMPLY WITH LOCAL JURISDICTIONAL REQUIREMENTS AND MANUAL OF UNIFORM TRAFFIC CONTROL DEVICES (MUTCD), LATEST EDITION, WHICHEVER IS MORE STRINGENT.
2. PRIOR TO ANY ROAD CONSTRUCTION, TRAFFIC CONTROL SIGNS AND DEVICES SHALL BE IN PLACE.
3. TRAFFIC CONTROL DEVICES FOR LANE CLOSURES INCLUDING SIGNS, CONES, BARRICADES, ETC. SHALL BE PLACED AS SHOWN ON PLANS. SIGNS SHALL NOT BE PLACED WITHOUT ACTUAL LANE CLOSURES AND SHALL BE IMMEDIATELY REMOVED UPON REMOVAL OF THE CLOSURES.
4. SELECTION, PLACEMENT, MAINTENANCE, AND PROTECTION OF TRAFFIC, PEDESTRIANS, AND WORKERS SHALL BE IN ACCORDANCE WITH THE MANUAL OF UNIFORM TRAFFIC CONTROL DEVICES (MUTCD) – PART VI "TEMPORARY TRAFFIC CONTROL", AND LOCAL JURISDICTIONAL REQUIREMENTS UNLESS OTHERWISE NOTED IN THE PLANS AND SPECIFICATIONS, AND SHALL BE APPROVED BY THE APPROPRIATE HIGHWAY AUTHORITY HAVING JURISDICTION.
5. ADVANCE WARNING SIGNS, DISTANCES, AND TAPER LENGTHS MAY BE EXTENDED TO ADJUST FOR REDUCED VISIBILITY DUE TO HORIZONTAL AND VERTICAL CURVATURE OF THE ROADWAY AND FOR ACTUAL TRAFFIC SPEEDS IF IN EXCESS OF POSTED SPEED LIMITS.
6. TAPERS SHALL BE LOCATED TO MAXIMIZE THE VISIBILITY OF THEIR TOTAL LENGTH.
7. CONFLICTING OR NON-OPERATING SIGNAL INDICATIONS ON THE (E) TRAFFIC SIGNAL SYSTEMS SHALL BE BAGGED OR COVERED.
8. ALL (E) ROAD SIGNS, PAVEMENT MARKINGS AND/OR PLOWABLE PAVEMENT REFLECTORS WHICH CONFLICT WITH THE (N) TRAFFIC CONTROL PLAN SHALL BE COVERED, REMOVED, OR RELOCATED. ALL TRAFFIC CONTROL DEVICES SHALL BE RESTORED TO MATCH PRE-CONSTRUCTION CONDITION AFTER COMPLETION OF WORK.
9. CONTRACTOR SHALL CONTACT LOCAL AUTHORITY HAVING HIGHWAY JURISDICTION AND PROVIDE ADDITIONAL "FLAGMEN" OR POLICE SUPERVISION, IF REQUIRED.
10. ALL EXCAVATED AREAS WITHIN OR ADJACENT TO THE ROADWAY SHALL BE BACKFILLED AND PLACED ON A MINIMUM 6H:1V SLOPE PRIOR TO END OF EACH WORK DAY. OTHER EXCAVATED AREAS WITHIN THE CLEAR ZONE ARE TO BE EITHER BACKFILLED OR PRECAST CONCRETE CURB BARRIER CONSTRUCTION BARRIER SET TEMPORARILY IN PLACE TO SHIELD VEHICULAR AND PEDESTRIAN TRAFFIC.
11. WHERE DICTATED BY LOCAL CONDITIONS, THE CONTRACTOR SHALL MAKE PROVISIONS FOR MAINTAINING PEDESTRIAN AND WORKER CROSSING LOCATIONS IN ACCORDANCE WITH ALL APPLICABLE CODES AND OSHA REQUIREMENTS.
12. CONSTRUCTION ZONE SPEED LIMIT IF REDUCED FROM POSTED LIMITS SHALL BE IN ACCORDANCE WITH MUTCD AND WILL BE DETERMINED BY THE AUTHORITY HAVING JURISDICTION.
13. THERE SHALL BE NO WORKERS, EQUIPMENT, OR OTHER VEHICLES IN THE BUFFER SPACE OR THE ROLL AHEAD SPACE.
14. DRIVEWAYS AND/OR SIDE STREETS ENTERING THE ROADWAY AFTER THE FIRST ADVANCE WARNING SIGN SHALL BE PROVIDED WITH AT LEAST ONE W20-1 SIGN (ROAD WORK AHEAD) AS A MINIMUM.
15. CONES MAY BE SUBSTITUTED FOR DRUMS AND INSTALLED UPON THE APPROVAL OF THE AUTHORITY HAVING JURISDICTION PROVIDED THEY COMPLY WITH MUTCD.
16. THE SPACING BETWEEN CONES, TUBULAR MARKERS, VERTICAL PANELS, DRUMS, AND BARRICADES SHOULD NOT EXCEED A DISTANCE IN FEET EQUAL TO 1.0 TIMES THE SPEED LIMIT IN MPH WHEN USED FOR TAPER CHANNELIZATION, AND A DISTANCE IN FEET EQUAL TO 2.0 TIMES THE SPEED LIMIT IN MPH WHEN USED FOR TANGENT CHANNELIZATION.
17. WHEN CHANNELIZATION DEVICES HAVE THE POTENTIAL OF LEADING VEHICULAR TRAFFIC OUT OF THE INTENDED VEHICULAR TRAFFIC SPACE, THE CHANNELIZATION DEVICES SHOULD BE EXTENDED A DISTANCE IN FEET OF 2.0 TIMES THE SPEED LIMIT IN MPH BEYOND THE DOWNSTREAM END OF THE TRANSITION AREA.
18. TAPER LENGTHS ARE CALCULATED AS FOLLOWS:
 $L = WS^2/60$ (40 MPH AND HIGHER) OR $L2 = WS$ (OVER 40 MPH),
 WHERE W= OFFSET WIDTH (FT), S= TRAFFIC SPEED (MPH).

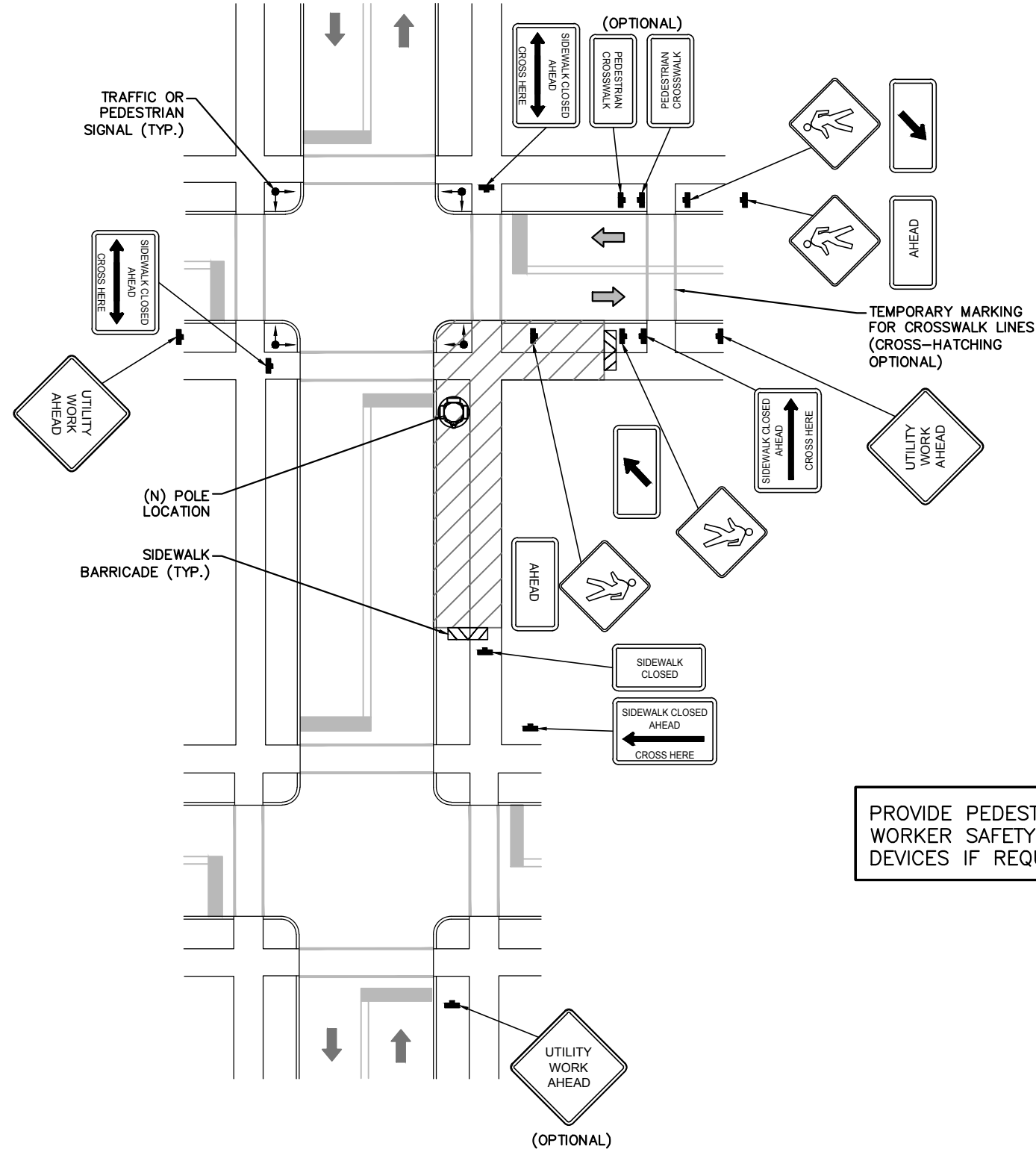

3475 PIEDMONT ROAD NE
 SUITE 1000
 ATLANTA, GEORGIA 30305
 PHONE: (312) 638-5400

PROJECT NO: ER600201
 DRAWN BY: J. RECAÑA
 CHECKED BY: C. O'DELL

PRELIM - NOT FOR CONSTRUCTION

08.21.17 PRELIM - NOT FOR CONSTRUCTION



IT IS A VIOLATION OF THE LAW FOR ANY PERSON, UNLESS THEY ARE ACTING UNDER THE DIRECTION OF A LICENSED PROFESSIONAL ENGINEER, TO ALTER THIS DOCUMENT

BS90XSC47F
 9MAB001157F
 ENMORE ST &
 MA-133/HAVERHILL ST
 ANDOVER, MA 01810
 UTILITY POLE

SHEET TITLE
PEDESTRIAN SAFETY PLAN

SHEET NUMBER
TC-2

GENERAL CONSTRUCTION NOTES:

1. ALL WORK SHALL CONFORM TO THE REQUIREMENTS OF THE LOCAL BUILDING CODE, THE LATEST ADOPTED EDITION AND ALL OTHER APPLICABLE CODES AND ORDINANCES.
2. CONTRACTOR SHALL CONSTRUCT SITE IN ACCORDANCE WITH THESE DRAWINGS AND LATEST MOBILITIE CONSTRUCTION STANDARDS. THE SPECIFICATION IS THE RULING DOCUMENT AND ANY DISCREPANCIES BETWEEN THE SPECIFICATION AND THE CONSTRUCTION DRAWINGS SHALL BE BROUGHT TO THE ATTENTION OF THE ARCHITECT/ENGINEER OR MOBILITIE CM PRIOR TO THE COMMENCEMENT OF WORK.
3. CONTRACTOR SHALL VISIT THE JOB SITE AND SHALL FAMILIARIZE THEMSELVES WITH ALL CONDITIONS AFFECTING THE (N) WORK AND SHALL MAKE PROVISIONS AS TO THE COST THEREOF. CONTRACTOR SHALL BE RESPONSIBLE FOR FAMILIARIZING THEMSELVES WITH ALL CONTRACT DOCUMENTS, FIELD CONDITIONS AND DIMENSIONS AND CONFIRMING THAT THE WORK MAY BE ACCOMPLISHED, AS SHOWN, PRIOR TO PROCEEDING WITH CONSTRUCTION. ANY DISCREPANCIES SHALL BE BROUGHT TO THE ATTENTION OF THE ARCHITECT/ENGINEER OR MOBILITIE CM PRIOR TO THE COMMENCEMENT OF WORK. NO COMPENSATION WILL BE AWARDED BASED ON CLAIM OF LACK OF KNOWLEDGE OF FIELD CONDITIONS.
4. IT IS NOT THE INTENT OF THESE PLANS TO SHOW EVERY MINOR DETAIL OF CONSTRUCTION. CONTRACTOR IS REQUIRED TO FURNISH AND INSTALL ANY/ALL ITEMS FOR A COMPLETE AND FULLY FUNCTIONAL SYSTEM SUBJECT ONLY TO OWNER-SUPPLIED ITEMS. CONTRACTOR SHALL PROVIDE ANY/ALL REQUIREMENTS FOR THE EQUIPMENT TO BE PLACED IN PROPER WORKING ORDER.
5. PLANS ARE NOT TO BE SCALED. THESE PLANS ARE INTENDED TO BE A DIAGRAMMATIC OUTLINE ONLY UNLESS OTHERWISE NOTED. THE WORK SHALL INCLUDE FURNISHING MATERIALS, EQUIPMENT AND APPURTENANCES, AND LABOR NECESSARY TO EFFECT ALL INSTALLATIONS AS INDICATED ON THE DRAWINGS. OWNER PROVIDED AND CONTRACTOR INSTALLED MATERIALS WILL INCLUDE THE FOLLOWING, UNLESS NOTED OTHERWISE:
 - A) TRANSMITTER
 - B) UHF ANTENNA AND MOUNTING BRACKETS, GPS UNIT AND KU BACKHAUL
 - C) UHF COAX AND HANGERS
 - D) INTEGRATED LOAD CENTER
6. DIMENSIONS SHOWN ARE TO FINISH SURFACES UNLESS OTHERWISE NOTED. SPACING BETWEEN EQUIPMENT IS REQUIRED CLEARANCE. THEREFORE, IT IS CRITICAL TO FIELD VERIFY DIMENSIONS. SHOULD THERE BE ANY QUESTIONS REGARDING THE CONTRACT DOCUMENTS, (E) CONDITIONS AND/OR DESIGN INTENT, THE CONTRACTOR SHALL BE RESPONSIBLE FOR REPORTING ANY DISCREPANCIES TO THE ATTENTION OF THE MOBILITIE CM, IN WRITING, PRIOR TO THE COMMENCEMENT OF WORK.
7. DETAILS PROVIDED ARE FOR THE PURPOSE OF SHOWING DESIGN INTENT. MODIFICATIONS MAY BE REQUIRED TO SUIT JOB DIMENSIONS OR SITE CONDITIONS, AND SUCH MODIFICATIONS SHALL BE INCLUDED AS PART OF THE WORK.
8. CONTRACTOR SHALL PAY FOR APPLICABLE PERMITS, FEES, INSPECTIONS AND TESTING. CONTRACTOR IS TO OBTAIN PERMITS AND APPROVED SUBMITTALS PRIOR TO ORDERING MATERIALS AND THE COMMENCEMENT OF WORK.
9. THE TERM "PROVIDE" USED IN CONSTRUCTION DOCUMENTS AND SPECIFICATIONS, INDICATES THAT THE CONTRACTOR SHALL FURNISH AND INSTALL.
10. CONTRACTOR SHALL RECEIVE CLARIFICATION IN WRITING, AND SHALL RECEIVE IN WRITING AUTHORIZATION TO PROCEED BEFORE STARTING WORK ON ANY ITEMS NOT CLEARLY DEFINED OR IDENTIFIED BY THE CONTRACT DOCUMENTS.
11. CONTRACTOR SHALL SUPERVISE AND DIRECT THE WORK USING ACCEPTED INDUSTRY-STANDARD SKILLS AND ATTENTION. CONTRACTOR SHALL BE SOLELY RESPONSIBLE FOR CONSTRUCTION MEANS, METHODS, TECHNIQUES, SEQUENCES AND PROCEDURES AND FOR COORDINATING ALL PORTIONS OF THE WORK UNDER CONTRACT, UNLESS OTHERWISE NOTED.
12. CONTRACTOR SHALL BE RESPONSIBLE FOR THE SAFETY OF THE WORK AREA, ADJACENT AREAS AND BUILDING OCCUPANTS THAT ARE LIKELY TO BE AFFECTED BY THE WORK UNDER THIS CONTRACT. WORK SHALL CONFORM TO ALL OSHA REQUIREMENTS.
13. CONTRACTOR SHALL COORDINATE THEIR WORK WITH THE MOBILITIE CM AND SCHEDULE THEIR ACTIVITIES AND WORKING HOURS IN ACCORDANCE WITH THE REQUIREMENTS.

14. CONTRACTOR SHALL BE RESPONSIBLE FOR COORDINATING THEIR WORK WITH THE WORK OF OTHERS AS IT MAY RELATE TO RADIO EQUIPMENT, ANTENNAS AND ANY OTHER PORTIONS OF THE WORK.
15. CONTRACTOR SHALL INSTALL ALL EQUIPMENT AND MATERIALS IN ACCORDANCE WITH MANUFACTURERS RECOMMENDATIONS UNLESS SPECIFICALLY OTHERWISE INDICATED OR WHERE LOCAL CODES OR REGULATIONS TAKE PRECEDENCE.
16. CONTRACTOR SHALL MAKE NECESSARY PROVISIONS TO PROTECT (E) SURFACES, EQUIPMENT, IMPROVEMENTS, PIPING ETC. AND IMMEDIATE REPAIR, TO NEW CONDITION, ANY DAMAGE THAT OCCURS DURING CONSTRUCTION AT THE SOLE COST OF THE CONTRACTOR.
17. IN DRILLING HOLES, OR CORING, INTO CONCRETE WHETHER FOR FASTENING OR ANCHORING PURPOSES, OR PENETRATIONS THROUGH THE FLOOR FOR CONDUIT RUNS, PIPE RUNS, ETC., MUST BE CLEARLY UNDERSTOOD THAT REINFORCING STEEL SHALL NOT BE DRILLED INTO, CUT OR DAMAGED UNDER ANY CIRCUMSTANCES (UNLESS NOTED OTHERWISE). LOCATIONS OF REINFORCING STEEL ARE NOT DEFINITELY KNOWN AND THEREFORE MUST BE LOCATED BY THE CONTRACTOR USING APPROPRIATE METHODS AND EQUIPMENT PRIOR TO ANY DRILLING OR CORING OPERATIONS IN (E) CONCRETE.
18. CONTRACTOR SHALL REPAIR, TO NEW CONDITION, ALL (E) WALL SURFACES DAMAGED DURING CONSTRUCTION SUCH THAT THEY MATCH AND BLEND IN WITH ADJACENT SURFACES.
19. CONTRACTOR SHALL SEAL PENETRATIONS THROUGH FIRE RATED ASSEMBLIES OR MATERIALS WITH U.L. LISTED AND FIRE CODE APPROVED MATERIALS AND SYSTEMS THAT MEET OR EXCEED THE RATING OF THE ASSEMBLY IN WHICH THE NEW PENETRATION IS PLACED.
20. CONTRACTOR SHALL KEEP CONTRACT AREA CLEAN, HAZARD FREE, AND DISPOSE OF ALL DIRT, DEBRIS, AND RUBBISH. EQUIPMENT NOT SPECIFIED AS REMAINING ON THE PROPERTY OF THE OWNER SHALL BE REMOVED. LEAVE PREMISES IN CLEAN CONDITION AND FREE FROM PAINT SPOTS, DUST, OR SMUDGES OF ANY NATURE. CONTRACTOR SHALL BE RESPONSIBLE FOR MAINTAINING ALL ITEMS UNTIL COMPLETION OF CONSTRUCTION.
21. MINIMUM BEND RADIUS OF ANTENNA CABLES SHALL BE IN ACCORDANCE WITH CABLE MANUFACTURERS RECOMMENDATIONS.
22. CONTRACTOR SHALL MINIMIZE DISTURBANCE TO (E) SITE DURING CONSTRUCTION. EROSION CONTROL MEASURES, IF REQUIRED DURING CONSTRUCTION SHALL BE IN CONFORMANCE WITH JURISDICTIONAL OR STATE AND LOCAL GUIDELINES FOR EROSION AND SEDIMENT CONTROL AND COORDINATED WITH LOCAL REGULATORY AUTHORITIES. CONTRACTOR SHALL BE RESPONSIBLE FOR MAINTENANCE OF ANY EROSION CONTROL MEASURES, RECORD-KEEPING, MONITORING, AND REPORTING TO THE OWNER AND REGULATORY AUTHORITIES.
23. ALL CONSTRUCTION WORK IS TO ADHERE TO APPLICANT'S INTEGRATED CONSTRUCTION STANDARDS UNLESS STATE OR LOCAL CODE IS MORE STRINGENT.
24. THE INTENT OF THE PLANS AND SPECIFICATIONS IS TO PERFORM THE CONSTRUCTION IN ACCORDANCE PER STATE BUILDING STANDARDS CODE AND STATE CODE OF REGULATIONS. SHOULD ANY CONDITIONS DEVELOP NOT COVERED BY THE APPROVED PLANS AND SPECIFICATIONS WHEREIN THE FINISHED WORK WILL NOT COMPLY PER STATE CODE OF REGULATIONS, A SCOPE OF WORK DETAILING AND SPECIFYING THE REQUIRED WORK SHALL BE SUBMITTED TO AND APPROVED BY THE JURISDICTION BEFORE PROCEEDING WITH THE WORK. A CHANGE ORDER FOR THAT SCOPE SHALL BE SUBMITTED TO THE MOBILITIE CM PRIOR TO PROCEEDING WITH THE WORK.
25. ADEQUATE AND REQUIRED LIABILITY INSURANCE SHALL BE PROVIDED BY THE CONTRACTOR FOR PROTECTION AGAINST PUBLIC LOSS AND ANY/ALL PROPERTY DAMAGE FOR THE DURATION OF WORK.
26. CONTRACTOR SHALL GUARANTEE ANY/ALL MATERIALS AND WORK FREE FROM DEFECTS FOR A PERIOD OF NOT LESS THAN ONE YEAR FROM DATE OF ACCEPTANCE. ANY CORRECTIVE WORK SHALL BE COMPLETED AT THE SOLE COST OF THE CONTRACTOR.

ELECTRICAL NOTES:

1. ELECTRICAL CONTRACTOR SHALL SUPPLY AND INSTALL ANY/ALL ELECTRICAL WORK INDICATED. ANY/ALL CONSTRUCTION SHALL BE IN ACCORDANCE W/DRAWINGS AND ANY/ALL APPLICABLE SPECIFICATIONS. IF ANY PROBLEMS ARE ENCOUNTERED BY COMPLYING WITH THESE REQUIREMENTS, CONTRACTOR SHALL NOTIFY MOBILITIE CM AS SOON AS POSSIBLE, AFTER THE DISCOVERY OF THE PROBLEMS, AND SHALL NOT PROCEED WITH THAT PORTION OF WORK, UNTIL THE MOBILITIE CM HAS DIRECTED THE CORRECTIVE ACTIONS TO BE TAKEN.

2. ELECTRICAL CONTRACTOR SHALL VISIT THE JOB SITE AND FAMILIARIZE THEMSELVES WITH ANY/ALL CONDITIONS AFFECTING ELECTRICAL AND COMMUNICATION INSTALLATION AND MAKE PROVISIONS AS TO THE COST THEREOF. ALL (E) CONDITIONS OF ELECTRICAL EQUIP., ETC., THAT ARE PART OF THE FINAL SYSTEM, SHALL BE VERIFIED BY THE CONTRACTOR, PRIOR TO THE SUBMITTING OF THEIR BID. FAILURE TO COMPLY WITH THIS PARAGRAPH WILL IN NO WAY RELIEVE CONTRACTOR OF PERFORMING ALL WORK NECESSARY FOR A COMPLETE AND WORKING SYSTEM.
3. ALL WORK SHALL BE PERFORMED IN ACCORDANCE WITH THE LATEST EDITION OF THE NEC, ALL CODES AND ORDINANCES OF THE LOCAL JURISDICTION, AND POWER & TELEPHONE COMPANIES HAVING JURISDICTION AND SHALL INCLUDE BUT ARE NOT BE LIMITED TO:
 - A) UL - UNDERWRITERS LABORATORIES
 - B) NEC - NATIONAL ELECTRICAL CODE
 - C) NEMA - NATIONAL ELECTRICAL MANUFACTURERS ASSOC.
 - D) OSHA - OCCUPATIONAL SAFETY AND HEALTH ACT
 - E) SBC - STANDARD BUILDING CODE
 - F) NFPA - NATIONAL FIRE PROTECTION AGENCY
 - G) ANSI - AMERICAN NATIONAL STANDARDS INSTITUTE
 - H) IEEE - INSTITUTE OF ELECTRICAL AND ELECTRONICS ENGINEERS
 - I) ASTM - AMERICAN SOCIETY FOR TESTING MATERIALS
4. REFER TO SITE PLANS AND ELEVATIONS FOR EXACT LOCATIONS OF ALL EQUIPMENT, AND CONFIRM WITH MOBILITIE CM ANY SIZES AND LOCATIONS WHEN NEEDED.
5. (E) SERVICES: CONTRACTOR SHALL NOT INTERRUPT (E) SERVICES WITHOUT WRITTEN PERMISSION OF THE OWNER.
6. CONTRACTOR SHALL CONFIRM WITH LOCAL UTILITY COMPANY ANY/ALL REQUIREMENTS SUCH AS THE: LUG SIZE RESTRICTIONS, CONDUIT ENTRY, SIZE OF TRANSFORMERS, SCHEDULED DOWNTIME FOR THE OWNERS' CONFIRMATION, ETC... ANY/ALL CONFLICTS SHALL BE BROUGHT TO THE ATTENTION OF THE MOBILITIE CM, PRIOR TO BEGINNING ANY WORK.
7. MINIMUM WIRE SIZE SHALL BE #12 AWG, NOT INCLUDING CONTROL WIRING, UNLESS NOTED OTHERWISE. ALL CONDUCTORS SHALL BE COPPER WITH THWN INSULATION, UNLESS OTHERWISE NOTED.
8. OUTLET BOXES SHALL BE PRESSED STEEL IN DRY LOCATIONS, CAST ALLOY WITH THREADED HUBS IN WET/DAMP LOCATIONS AND SPECIAL ENCLOSURES FOR OTHER CLASSIFIED AREAS.
9. IT IS NOT THE INTENT OF THESE PLANS TO SHOW EVERY MINOR DETAIL OF THE CONSTRUCTION. CONTRACTOR IS EXPECTED TO FURNISH AND INSTALL ALL ITEMS FOR A COMPLETE ELECTRICAL SYSTEM AND PROVIDE ALL REQUIREMENTS FOR THE EQUIPMENT TO BE PLACED IN PROPER WORKING ORDER.
10. ELECTRICAL SYSTEM SHALL BE AS COMPLETELY AND EFFECTIVELY GROUNDED, AS REQUIRED BY SPECIFICATIONS, SET FORTH BY APPLICANT.
11. ALL WORK SHALL BE PERFORMED BY A LICENSED ELECTRICAL CONTRACTOR IN A FIRST CLASS, WORKMANLIKE MANNER. THE COMPLETED SYSTEM SHALL BE FULLY FUNCTIONAL AND SHALL BE APPROVED BY THE MOBILITIE CM AND LOCAL JURISDICTION. ANY DEFICIENCIES SHALL BE CORRECTED BY AN ELECTRICAL CONTRACTOR AT THE SOLE COST OF THE CONTRACTOR.
12. ALL WORK SHALL BE COORDINATED WITH OTHER TRADES TO AVOID INTERFERENCE WITH THE PROGRESS OF CONSTRUCTION.



3475 PIEDMONT ROAD NE
SUITE 1000
ATLANTA, GEORGIA 30305
PHONE: (312) 638-5400

PROJECT NO:	ER600201
DRAWN BY:	J. RECAÑA
CHECKED BY:	C. O'DELL

PRELIM - NOT FOR CONSTRUCTION

A	08.21.17	PRELIM - NOT FOR CONSTRUCTION
---	----------	-------------------------------



IT IS A VIOLATION OF THE LAW FOR ANY PERSON, UNLESS THEY ARE ACTING UNDER THE DIRECTION OF A LICENSED PROFESSIONAL ENGINEER, TO ALTER THIS DOCUMENT

BS90XSC47F
9MAB001157F
ENMORE ST &
MA-133/HAVERHILL ST
ANDOVER, MA 01810
UTILITY POLE

SHEET TITLE
GENERAL NOTES

SHEET NUMBER
GN-1

ELECTRICAL NOTES CONT'D

13. THE CORRECTION OF ANY DEFECTS SHALL BE COMPLETED BY THE CONTRACTOR WITHOUT ANY ADDITIONAL CHARGE AND SHALL INCLUDE THE REPLACEMENT OR THE REPAIR OF ANY OTHER PHASE OF THE INSTALLATION, WHICH MAY HAVE BEEN DAMAGED THEREIN.
14. CONTRACTOR SHALL PROVIDE AND INSTALL CONDUIT, CONDUCTORS, PULL WIRES, BOXES, COVER PLATES AND DEVICES FOR ALL OUTLETS AS INDICATED.
15. DITCHING AND BACK FILL: CONTRACTOR SHALL PROVIDE FOR ALL UNDERGROUND INSTALLED CONDUIT AND/OR CABLES INCLUDING EXCAVATION AND BACKFILLING AND COMPACTION. REFER TO NOTES AND REQUIREMENTS 'EXCAVATION, AND BACKFILLING.
16. MATERIALS, PRODUCTS AND EQUIPMENT, INCLUDING ALL COMPONENTS THEREOF, SHALL BE NEW AND SHALL APPEAR ON THE LIST OF U.L. APPROVED ITEMS AND SHALL MEET OR EXCEED THE REQUIREMENTS OF THE NEC, NEMA AND IECE.
17. CONTRACTOR SHALL SUBMIT SHOP DRAWINGS OR MANUFACTURER'S CATALOG INFORMATION OF ANY/ALL EQUIPMENT AND ALL OTHER ELECTRICAL ITEMS FOR APPROVAL BY THE MOBILITIE CM PRIOR TO INSTALLATION.
18. ANY CUTTING OR PATCHING DEEMED NECESSARY FOR ELECTRICAL WORK IS THE ELECTRICAL CONTRACTOR'S RESPONSIBILITY AND SHALL BE INCLUDED IN THE COST FOR WORK AND PERFORMED TO THE SATISFACTION OF THE MOBILITIE CM UPON FINAL ACCEPTANCE.
19. THE ELECTRICAL CONTRACTOR SHALL LABEL ALL PANELS WITH ONLY TYPEWRITTEN DIRECTORIES. ALL ELECTRICAL WIRING SHALL BE THE RESPONSIBILITY OF THE ELECTRICAL CONTRACTOR.
20. DISCONNECT SWITCHES SHALL BE UL-RATED, H.P. RATED HEAVY-DUTY, QUICK-MAKE AND QUICK-BREAK ENCLOSURES, AS REQUIRED BY EXPOSURE TYPE.
21. ALL CONNECTIONS SHALL BE MADE WITH A PROTECTIVE COATING OF AN ANTI-OXIDE COMPOUND KNOWN AS "NO-OXIDE A" BY DEARBORNE CHEMICAL CO. COAT ALL WIRE SURFACES BEFORE CONNECTING. EXPOSED COPPER SURFACES, INCLUDING GROUND BARS, SHALL BE TREATED - NO SUBSTITUTIONS.
22. RACEWAYS: CONDUIT SHALL BE SCHEDULE 80 PVC MEETING OR EXCEEDING NEMA TC2 - 1990. CONTRACTOR SHALL PLUG AND CAP EACH END OF SPARE AND EMPTY CONDUITS AND PROVIDE TWO SEPARATE PULL STRINGS - 200 LBS TEST POLYETHYLENE CORD. ALL CONDUIT BENDS SHALL BE A MINIMUM OF 2 FT. RADIUS. RGS CONDUITS WHEN SPECIFIED, SHALL MEET UL-6 FOR GALVANIZED STEEL. ALL FITTINGS SHALL BE SUITABLE FOR USE WITH THREADED RIGID CONDUIT. COAT ALL THREADS WITH 'BRITE ZINC' OR 'COLD GALV'.
23. SUPPORT OF ALL ELECTRICAL WORK SHALL BE AS REQUIRED BY NEC.
24. CONDUCTORS: CONTRACTOR SHALL USE 98% CONDUCTIVITY COPPER WITH TYPE THWN INSULATION, UNLESS OTHERWISE NOTED, 600 VOLT, COLOR CODED. USE SOLID CONDUCTORS FOR WIRE UP TO AND INCLUDING NO. 8 AWG. USE STRANDED CONDUCTORS FOR WIRE ABOVE NO. 8 AWG.
25. CONNECTORS FOR POWER CONDUCTORS: CONTRACTOR SHALL USE PRESSURE TYPE INSULATED TWIST-ON CONNECTORS FOR NO. 10 AWG AND SMALLER. USE SOLDERLESS MECHANICAL TERMINAL LUGS FOR NO. 8 AWG AND LARGER.
26. SERVICE: AS SPECIFIED ON THE DRAWINGS. OWNER OR OWNER'S AGENT WILL APPLY FOR POWER. ALL PROVISIONS FOR TEMPORARY POWER WILL BE OBTAINED BY THE CONTRACTOR.
27. TELEPHONE OR FIBER SERVICE: CONTRACTOR SHALL PROVIDE EMPTY CONDUITS WITH PULL STRINGS AS INDICATED ON DRAWINGS.
28. ELECTRICAL AND TELCO/FIBER RACEWAYS TO BE BURIED A MINIMUM DEPTH OF 30", UNLESS OTHERWISE NOTED.
29. CONTRACTOR SHALL PLACE 6" WIDE DETECTABLE WARNING TAPE AT A DEPTH OF 6" BELOW GROUND AND DIRECTLY ABOVE ELECTRICAL AND TELCO SERVICE CONDUITS. CAUTIONS TAPE TO READ "CAUTION BURIED ELECTRIC" OR "BURIED TELECOM".
30. ALL BOLTS SHALL BE 3-16 STAINLESS STEEL

GROUNDING NOTES:

1. ALL HARDWARE SHALL BE 3-16 STAINLESS STEEL, INCLUDING LOCK WASHERS. COAT ALL SURFACES WITH AN ANTI-OXIDANT COMPOUND, AS SPECIFIED, BEFORE MATING. ALL HARDWARE SHALL BE STAINLESS STEEL 3/8 INCH DIAMETER OR SIZED TO MATCH COMPONENTS OR LOG SIZE.
2. FOR GROUND BOND TO STEEL ONLY: INSERT A CADMIUM FLAT WASHER BETWEEN LUG AND STEEL. COAT ALL SURFACES WITH AN ANTI-OXIDANT COMPOUND BEFORE MATING.
3. ALL STEEL CONDUIT SHALL BE BONDED AT BOTH ENDS WITH GROUNDING BUSHING.
4. ALL ELECTRICAL AND GROUNDING AT THE POLE SITE SHALL COMPLY WITH THE NATIONAL ELECTRICAL CODE (NEC), NATIONAL FIRE PROTECTION ASSOCIATION (NFPA) 780 (LATEST EDITION), AND MANUFACTURER.
5. ALL DETAILS ARE SHOWN IN GENERAL TERMS. ACTUAL GROUNDING INSTALLATION AND CONSTRUCTION MAY VARY DUE TO SITE SPECIFIC CONDITIONS.
6. GROUND ALL ANTENNA BASES, FRAMES, CABLE RUNS, AND OTHER METALLIC COMPONENTS USING #6 GROUND WIRES. FOLLOW ANTENNA AND BTS MANUFACTURER'S PRACTICES FOR GROUNDING REQUIREMENTS.
7. ALL GROUND CONNECTIONS SHALL BE #6 AWG, UNLESS OTHERWISE NOTED. USE SOLID COPPER, BLACK JACKETED WIRE ON NON WOOD POLES AND SOLID TINNED COPPER, BARE (NO JACKET) WIRES ON WOOD POLES. BLACK WIRES WILL USE A SINGLE STRIPE OF GREEN ELECTRICAL TAPE WITHIN 12" OF THE CONNECTION POINTS TO IDENTIFY AS GROUNDING WIRE.
8. NOTIFY ARCHITECT/ENGINEER IF THERE ARE ANY DIFFICULTIES INSTALLING GROUNDING SYSTEM DUE TO SITE SOIL CONDITIONS.
9. ALL HORIZONTALLY RUN GROUNDING CONDUCTORS SHALL BE INSTALLED A MINIMUM OF 30" BELOW GRADE/ 6" BELOW FROST-LINE IN TRENCH, UNLESS OTHERWISE NOTED. BACK FILL SHALL BE COMPACTED AS REQUIRED BY ARCHITECT/ENGINEER.
10. ALL GROUND CONDUCTORS SHALL BE RUN AS STRAIGHT AND SHORT AS POSSIBLE, WITH A MINIMUM 12" BENDING RADIUS NOT LESS THAN 90 DEGREES.
11. ACCEPTABLE CONNECTIONS FOR GROUNDING SYSTEM SHALL BE:
 - A. BURNDY, HY-GRADE U.L. LISTED CONNECTORS FOR OUTDOOR USE OR AS APPROVED BY APPLICANT PROJECT MANAGER.
 - B. CADWELD, EXOTHERMIC WELDS (WELDED CONNECTIONS).
 - C. ONE (1) OR (2) HOLES TINNED COPPER COMPRESSION (LONG BARREL) FITTINGS.
12. ALL CRIMPED CONNECTIONS SHALL HAVE EMBOSSED MANUFACTURER'S DIEMARK VISIBLE AT THE CRIMP (RESULTING FROM USE OF PROPER CRIMPING DEVICES) AND WEATHER-PROOFED WITH HEAT SHRINK.
13. ALL CONNECTION HARDWARE SHALL BE TYPE 3-16 STAINLESS STEEL (NOT ATTRACTED TO MAGNETS).
14. ELECTRICAL SERVICE EQUIPMENT GROUNDING SHALL COMPLY WITH NEC, ARTICLE 250-82 AND SHALL BOND ALL (E) AND NEW GROUNDING ELECTRODES. NEW GROUNDING ELECTRODE SHALL INCLUDE BUT NOT LIMITED TO GROUND RODS.

TESTING AND EQUIPMENT TURN UP REQUIREMENTS:

1. RF CABLE, DATA CABLE, RADIO EQUIPMENT AND BACK HAUL EQUIPMENT TESTING WILL COMPLY WITH CURRENT INDUSTRY STANDARDS AND OR THOSE STANDARDS OF THE EQUIPMENT MANUFACTURER OR PROVIDED TO THE CONTRACTOR PRIOR TO TESTING.
2. CONTRACTOR WILL USE THE APPROPRIATE CALIBRATED TESTING EQUIPMENT IN THE TESTING OF RF CABLE, DATA CABLE, RADIO EQUIPMENT AND BACK HAUL EQUIPMENT THAT MEET INDUSTRY STANDARDS OF THE MANUFACTURER OR THOSE STANDARDS PROVIDED TO THE CONTRACTOR PRIOR TO TESTING.

3. CONTRACTOR TO VERIFY AND RECORD ALL TEST RESULTS AND PROVIDE THESE RESULTS WITHIN THE FINAL CLOSE OUT PACKAGE.
4. ALL PERSONNEL INVOLVED IN THE TESTING OF RF CABLE, DATA CABLE, RADIO EQUIPMENT AND BACK HAUL EQUIPMENT WILL BE REQUIRED TO HAVE BEEN TRAINED AND OR CERTIFIED IN THE PROPER TESTING OF RF CABLE, DATA CABLE, RADIO EQUIPMENT AND BACK HAUL EQUIPMENT.
5. ALL TEST RESULTS SHALL BE TIME STAMPED, RECORDED AND PRESENTED PRIOR TO ENERGIZING AND TURN UP OF ANY EQUIPMENT.
6. GPS EQUIPMENT (WHEN REQUIRED) IS NOT TO BE TESTED OR ATTACHED TO ANY CABLING DURING TESTING, DOING SO WILL DAMAGE THE GPS UNIT.
7. PRIOR TO TESTING IF THE CONTRACTOR HAS ANY QUESTIONS ABOUT THE TESTING PROCEDURES THEY ARE TO CALL AND OBTAIN ASSISTANCE FROM A QUALIFIED DESIGNATED TESTING REPRESENTATIVE.
8. EQUIPMENT IS NOT TO BE ENERGIZED UNTIL ALL TESTING HAS BEEN COMPLETED, APPROVED AND THE APPROPRIATE AUTHORITY HAS BEEN NOTIFIED AND GIVES APPROVAL TO ENERGIZE THE EQUIPMENT.

SITE WORK NOTES:

1. DO NOT EXCAVATE OR DISTURB BEYOND THE PROPERTY LINES OR LEASE LINES, UNLESS OTHERWISE NOTED.
2. SIZE, LOCATION AND TYPE OF ANY UNDERGROUND UTILITIES OR IMPROVEMENTS SHALL BE ACCURATELY NOTED AND PLACED ON AS-BUILT DRAWINGS BY GENERAL CONTRACTOR AND ISSUED TO ARCHITECT/ENGINEER AT COMPLETION OF PROJECT.
3. ALL (E) UTILITIES, FACILITIES, CONDITIONS AND THEIR DIMENSIONS SHOWN ON PLANS HAVE BEEN PLOTTED FROM AVAILABLE RECORDS. THE ENGINEER AND OWNER ASSUME NO RESPONSIBILITY WHATSOEVER AS TO THE SUFFICIENCY OR ACCURACY OF THE INFORMATION SHOWN ON THE PLANS OR THE MANNER OF THEIR REMOVAL OR ADJUSTMENT. CONTRACTOR SHALL BE RESPONSIBLE FOR DETERMINING EXACT LOCATION OF ALL (E) UTILITIES AND FACILITIES PRIOR TO START OF CONSTRUCTION. CONTRACTOR SHALL ALSO OBTAIN FROM EACH UTILITY COMPANY DETAILED INFORMATION RELATIVE TO WORKING SCHEDULES AND METHODS OF REMOVING OR ADJUSTING (E) UTILITIES.
4. CONTRACTOR SHALL VERIFY ALL (E) UTILITIES BOTH HORIZONTALLY AND VERTICALLY PRIOR TO START OF CONSTRUCTION. ANY DISCREPANCIES OR DOUBTS AS TO THE INTERPRETATION OF PLANS SHALL BE IMMEDIATELY REPORTED TO THE ARCHITECT/ENGINEER OR MOBILITIE CM FOR RESOLUTION AND INSTRUCTION, AND NO FURTHER WORK SHALL BE PERFORMED UNTIL THE DISCREPANCY IS CHECKED AND CORRECTED BY THE ARCHITECT/ENGINEER. FAILURE TO SECURE SUCH INSTRUCTION MEANS CONTRACTOR WILL HAVE WORKED AT THEIR OWN RISK AND EXPENSE. CONTRACTOR SHALL CALL LOCAL UTILITY LOCATE HOT LINE, SUCH AS 811, FOR UTILITY LOCATIONS A MINIMUM OF 48 HOURS PRIOR TO START OF CONSTRUCTION.
5. ALL NEW AND (E) UTILITY STRUCTURES ON SITE AND IN AREAS TO BE DISTURBED BY CONSTRUCTION SHALL BE ADJUSTED TO FINISH ELEVATIONS PRIOR TO FINAL INSPECTION OF WORK. ANY COST RELATED TO ADJUSTING (E) STRUCTURES SHALL BE BORNE SOLELY BY THE CONTRACTOR.
6. GRADING OF THE SITE WORK AREA IS TO BE SMOOTH AND CONTINUOUS IN SLOPE AND IS TO FEATHER INTO (E) GRADES AT THE GRADING LIMITS.
7. ALL TEMPORARY EXCAVATIONS FOR THE INSTALLATION OF FOUNDATIONS, UTILITIES, ETC., SHALL BE PROPERLY LAID BACK OR BRACED IN ACCORDANCE WITH CORRECT OCCUPATIONAL SAFETY AND HEALTH ADMINISTRATION (OSHA) REQUIREMENTS.



3475 PIEDMONT ROAD NE
SUITE 1000
ATLANTA, GEORGIA 30305
PHONE: (312) 638-5400

PROJECT NO:	ER600201
DRAWN BY:	J. RECAÑA
CHECKED BY:	C. O'DELL

PRELIM - NOT FOR CONSTRUCTION

08.21.17 PRELIM - NOT FOR CONSTRUCTION



IT IS A VIOLATION OF THE LAW FOR ANY PERSON, UNLESS THEY ARE ACTING UNDER THE DIRECTION OF A LICENSED PROFESSIONAL ENGINEER, TO ALTER THIS DOCUMENT

BS90XSC47F
9MAB001157F
ENMORE ST &
MA-133/HAVERHILL ST
ANDOVER, MA 01810
UTILITY POLE

SHEET TITLE
GENERAL NOTES

SHEET NUMBER
GN-2

MOTION

I move, in accordance with the provisions of Massachusetts General Laws, Chapter 44, Section 53A, that the Board of Selectmen accept a gift of funds in the amount of \$_____ from the Lupoli Companies and approve the expenditure of said funds by the Dascomb Road Zoning Task Force to pay for peer reviews and studies as may be deemed necessary by the Task Force.

**GRANT AGREEMENT
BY AND BETWEEN
THE TOWN OF ANDOVER
AND
ANDOVER COMMUNITY ACCESS AND MEDIA, INC.**

This Grant Agreement is made this day of January 1, 2018 by and between the Town of Andover, Massachusetts, a municipal corporation, acting through its Town Manager, as authorized by the Board of Selectmen acting in its capacity as cable television license Issuing Authority (hereinafter also referred to as the “Town”), and Andover Community Access and Media, Inc. (hereinafter also referred to as “A-CAM” or the “Access Corporation”), a private, nonprofit, charitable, tax exempt access corporation duly established under the laws of the Commonwealth of Massachusetts, as public charity to serve broad non-profit public purposes consistent with Section 501(c)(3) of the internal revenue code. This Grant Agreement provides for grants for the support and stimulation of public and charitable purposes primarily to benefit the community as a whole, including support for and stimulation of nonprofit Public, Educational and Government (PEG) Access community programming and related charitable and educational benefits for the benefit of the general public who agree as follows:

RECITALS

WHEREAS, the Board of Selectmen, as statutory cable license Issuing Authority, granted a Cable Television Renewal License (the “Comcast License”) to Comcast of Massachusetts, I, Inc., (hereinafter also referred to as “Comcast”) for a ten (10) year term from October 15, 2017 through October 14, 2027;

WHEREAS, the Board of Selectmen, as statutory Issuing Authority, granted a Cable Television Final License (the “Verizon License”) to Verizon New England, Inc. (“Verizon”) for a seven (7) year term from July 22, 2017 through July 21, 2024;

WHEREAS, the respective cable television licenses referenced above provide to the Town and its residents certain PEG Access Channels, together with grant funding and support to promote

and stimulate broad non-profit charitable public educational PEG access operations, facilities, and equipment the Town and/or its designee (i.e. an access corporation) for charitable PEG Access operations, facilities and equipment to benefit the general public and the Town;

WHEREAS, a prior Grant Agreement between the Parties expires on December 31, 2017 (the “Prior Agreement”), and A-CAM has stated its interest in continuing to provide non-profit PEG Access programming, services, facilities and equipment to the Andover community, including, but not limited to its residents, and Andover institutions who substantially subscribe to the purposes of the Access Corporation (collectively hereinafter also referred to as “Access Users”) and to the Town;

WHEREAS, the Town, pursuant to and consistent with its authority as a municipal corporation and as authorized by the cable license Issuing Authority under applicable federal and state law, and pursuant to the provisions of the aforesaid Comcast and Verizon Licenses (the “Licenses”), enters into this Grant Agreement for the provision by A-CAM of PEG Access programming, services, facilities and equipment to the public and access users and Access Users, pursuant to the terms of this Grant Agreement and applicable law;

NOW THEREFORE, in consideration of the mutual promises and covenants set forth herein, the parties agree as follows:

SECTION 1. PURPOSE OF GRANT AGREEMENT

The purpose of this Grant Agreement is to promote and stimulate broad charitable and public services for the provision of PEG Access programming, services, facilities and equipment pursuant to the terms of this Grant Agreement, the Licenses and applicable law.

SECTION 2. TERM

(a) The Grant Agreement shall be for a five (5) year term, commencing on January 1, 2018 and running through and until December 31, 2022 unless earlier terminated as provided herein. This Grant Agreement may be extended by a written instrument signed by the authorized representative(s) of both parties subject to paragraph (b) of this Section 2.

(b) A-CAM shall give the Town Manager written notice of its request to renew this Grant

Agreement from January 1, 2024 through December 31, 2028 at least six (6) months prior to the expiration of the five (5) year period referenced in Paragraph (a) above. In response to a written notice of request to renew from A-CAM, the Town Manager shall, within sixty days (60) days of receipt of said notice, provide a written response to A-CAM as to whether it is willing to renew this Grant Agreement. If, as evidenced by the written notice(s) of A-CAM and a written response of the Town Manager, both parties are interested in renewing this Grant Agreement, the parties shall exercise best efforts to negotiate a renewal agreement prior to December 31, 2023.

(c) In the event of a renewal of or amendment(s) to either the Andover Comcast or Andover Verizon Licenses, the parties shall, upon the written request of either party, conduct good faith discussions about the possible need and/or the availability of financial resources for amendments to and/or clarification of any of the terms herein.

SECTION 3. SCOPE OF SERVICES, PEG ACCESS PROGRAMMING, SERVICES, FACILITIES AND EQUIPMENT

A-CAM shall provide Public, Educational and Government (“PEG”) Access programming services, facilities and equipment to the Town of Andover and Access Users (Andover residents and persons associated with an Andover business or organization), consistent with the grant funds provided to A-CAM pursuant to this Grant Agreement and the reasonable availability of access personnel, contractors and volunteers, and in accordance with the Licenses, applicable law and consistent with the requirements of the Internal Revenue Service and the Commonwealth of Massachusetts applicable to the operation of an organization exempt from taxation under Section 501(c)(3) of the Internal Revenue Code, as amended. (Unless otherwise provided in writing by the Board of Selectmen, said Access programming shall include Public, Educational and Government Access programming.) The services, facilities and equipment provided by A-CAM shall be provided to Access Users without unlawful discrimination. A-CAM’s responsibilities to provide access programming, services, facilities and equipment shall include the following, consistent with the funds available to A-CAM:

(a) Schedule, operate and maintain the PEG channels provided in accordance with the respective cable licenses. A-CAM and the Andover Public Schools shall coordinate and cooperate with respect to operation of the Educational Access Channel, unless otherwise directed by the Issuing Authority. A-CAM and the Town shall coordinate and cooperate with respect to operation of the Government Access Channel, unless otherwise directed by the Issuing Authority subject to such Government Access Channel requirements as are set forth in this Grant Agreement.

(b) All programming on the PEG Access Channels shall comply with applicable laws and regulations. The dedicated Educational Access Channel and the dedicated Government Access Channel shall not be used for Public Access programming or programming unrelated to Educational Access or Government Access, respectively, unless otherwise authorized in writing by the Issuing Authority;

(c) Responsibly manage the annual grant funding provided to and raised by A-CAM, including the funding provided pursuant to the Renewal License and pursuant to the Verizon License;

(d) Operate and maintain an Access studio, and purchase and/or lease equipment with the funds provided to and raised by A-CAM, including the funding provided pursuant to Section 7 below;

(e) Conduct and increase outreach and recruitment efforts and activities to increase membership and Access Users;

(f) Conduct training programs in the skills necessary to produce quality PEG Access programming. At a minimum, training programs shall be conducted and/or offered on an average of once per month over the course of each year, subject to availability of staff and/or volunteers as needed to provide such training;

(g) Provide technical assistance to Access Users, Town and School staff using Access Corporation staff and volunteers;

(h) Provide access to production and post-production equipment for Access Users;

(i) Establish rules, procedures and guidelines (including written Access User agreements, which shall be required for all Access Users) for use of the PEG Access Channels, facilities and equipment;

(j) Cablecast all public meetings of the Andover Board of Selectmen, the Andover School Committee, the Andover Planning Board, and the Andover Town Meetings, unless otherwise requested by the respective government body or unless unable to do so due to circumstances beyond the reasonable control of A-CAM, and such other Town of Andover meetings as requested, upon reasonable notice, by the respective government body and/or the Town Manager, subject to the funding provided A-CAM pursuant to this Agreement and the reasonable availability of Access personnel, contractors, and/or volunteers. Reasonable notice, which does not have to be written notice, shall be deemed to be five (5) business days. If the request for coverage of a government meeting is less than five (5) business days prior to the date of the meeting to be covered, A-CAM

shall reasonably attempt to comply with such request, working out any equipment and staffing scheduling to the best of its ability. The Issuing Authority retains the right to establish priority with respect to the cablecasting of government meetings. A-CAM shall comply with any lawful rules and reasonable requirements of the respective government body with respect to the camera and sound coverage of a meeting. Nothing contained in this subsection is intended to interfere with the rights of any person to videotape a governmental meeting pursuant to the Open Meeting Law;

(k) A-CAM shall upon a timely request of the Board of Selectmen, Town Manager or the School Committee provide at no cost to the Town one (1) "DVD" (or other appropriate media) copy of a government meeting previously cablecast by A-CAM, to the extent available. Further to the foregoing, A-CAM agrees to maintain a system for archiving municipal meetings it has recorded, and upon request of the Board of Selectmen or Town Manager, to enter good faith negotiations with respect to developing a municipal meeting video records archive system that meets the needs of the Town in a manner that is cost-effective and feasible for the parties;

(l) Assist the Andover Public Schools, if requested by the Superintendent of Schools and the Issuing Authority, with Educational Access programming, including the provision of technical assistance (it is not the intent of this Agreement that A-CAM shall directly or indirectly provide for or fund a school media director or teacher).

(m) Accomplish such other tasks relating to the operation, scheduling and/or management of the PEG Access Channels, facilities and equipment as necessary and appropriate.

(n) With respect to dues for members of A-CAM, fees shall be reduced or eliminated for students of the Andover Public Schools, or for an Andover resident attending any other school up through high school.

(o) With respect to A-CAM's continued use of Andover school space for studio facilities, the Parties acknowledge that continued use of Andover school space for studio facilities is not within the control of the Board of Selectmen and/or Town Manager, and such school use shall be determined by the School Department or Superintendent of Schools as applicable and subject to applicable law. It shall be a condition hereof, subject to written approval of the Superintendent of Schools, that A-CAM annually pay to the Andover School Department such base rent as may be negotiated between the School Department and A-CAM and otherwise comply with such lease or school use agreement as may be entered into between the School Department and A-CAM.

(p) Further to A-CAM's performance hereunder, A-CAM acknowledges that the Town is providing A-CAM additional funding hereunder, as set forth in Section 7 below, and subject to

any applicable laws affecting Town appropriation of grant funding, subject to A-CAM's exercising diligent efforts to increase and further improve performance and services directed towards the following PEG Access goals and objectives consistent with the level of such additional funding:

- Promoting greater awareness and outreach of ACAM's resources for developing community PEG access programming;
- Facilitating and supporting the production of additional community PEG access programming;
- Providing and supporting cablecasting and broadcasting education and learning opportunities for Andover public school students;
- Increasing the amount of local government public meeting coverage to additional Town boards and committees;
- Establishing a standardized and advertised schedule for recablecasting the regular public meetings of Town boards;
- Improving the AV quality and reliability of both cable and internet streamed PEG program cablecasts, within the reasonable control of ACAM;
- Reducing the amount of PEG channel downtime caused by power and equipment failures, within the reasonable control of ACAM;
- Expanding the number of locations within town and school facilities that are available for PEG cablecasting of public meetings and events, subject to the Town providing additional funding to do so.

SECTION 4. PROVIDING OPEN AND EQUAL ACCESS TO ACCESS USERS

A-CAM agrees to keep the Public Access Channel open to all potential Access Users regardless of their viewpoint, subject to FCC regulations and other applicable laws and regulations.

A-CAM shall develop and enforce policies and procedures which are designed to promote local use of the channel(s) and make programming accessible to residents, consistent with such time, manner, and place regulations, including safe harbor and reasonable scheduling provisions, as are appropriate and lawful to provide for and promote the use of PEG Access Channels, equipment and facilities. Notwithstanding the foregoing, A-CAM may implement lawful program disclaimer and/or disclosure requirements to provide viewers with advisories or information about adult content of specific public access programs, and may require disclosure of the name(s) of program producers and/or the name of the person sponsoring submission of a program, and may otherwise take lawful steps to prevent copyright violations, defamation, obscenity or other unlawful content. Cablecasting of other programs may be subject to lawful scheduling or limitation, in accordance with Access Corporation operating rules and subject to applicable law. Notwithstanding the foregoing, the Town shall retain primary control over the policies and procedures governing access to and use of the Government and Educational Access channels.

SECTION 5. NON-COMMERCIAL PROGRAMMING

(a) All Access programming cablecast by A-CAM shall be non-commercial.

(b) Nothing in the Agreement shall prohibit A-CAM from including an appropriate underwriting acknowledgment before or after a Public, Government or Educational Access program, to the extent otherwise not prohibited by applicable law, including but not limited to Internal Revenue Service requirements regarding 501(c)(3) organizations, and or the terms of a cable license.

(c) A-CAM may charge a reasonable fee, subject to applicable Internal Revenue Service requirements regarding 501(c)(3) organizations, for the following:

- (i) Services lawfully provided to Access Users by a PEG access corporation for a fee; and
- (ii) Services lawfully provided to third parties for a fee, including tape dubbing (i.e. the provision of videotapes/dvds of particular access programs), to the extent otherwise not prohibited by applicable law.

SECTION 6. COPYRIGHT CLEARANCE

A-CAM shall, consistent with applicable law, require the respective Access User to obtain all rights, consents, releases and other authorizations as may be applicable to all material cablecast and clearances and authorizations from broadcast stations, networks, sponsors, music licensing

organizations representatives, and without limitation from the foregoing, from any and all other person(s) as may be necessary to transmit its or their program material over the Access Channel in a lawful manner. A-CAM shall, consistent with applicable law, require the respective Access User to sign a user form or agreement wherein the Access User acknowledges responsibility for the Access User's own programs, content and acts and omissions, and indemnifying A-CAM for any acts or omissions arising in connection with the Access User's access activities.

SECTION 7. GRANT FUNDING AND EQUIPMENT OF THE ACCESS CORPORATION

- (a) The Town shall provide A-CAM with the following operational grant funding subject to any applicable laws:
- (i) The Town shall provide a payment of Three Hundred and Eleven Thousand, One Hundred and Thirty Seven Dollars (\$311,137) to A-CAM for the first contract year. The first payment shall be made within fifteen (15) days of the execution of this Access Agreement, in the amount of One Hundred Fifty-five Thousand, Five Hundred and Sixty Eight Dollars and Fifty Cents (\$155,568.50) and the second payment of One Hundred Fifty-five Thousand, Five Hundred and Sixty Eight Dollars and Fifty Cents (\$155,568.50) shall be made by July 15, 2018, with payments to be paid from PEG Access funding paid to date by Comcast to the Town, pursuant to Article 6 of the Comcast Renewal License; and paid from PEG Access funding payments paid to date by Verizon to the Town, pursuant to Article 5 of the Verizon License.
 - (ii) No later than November 1, 2018 and each year thereafter, A-CAM shall submit a detailed annual operating budget to the Town, addressed to the attention of the Town Manager.
 - (iii) The Town shall provide A-CAM with PEG Access grant funding in two (2) equal payments on or before January 15 and July 15 of each subsequent contract year from access funding payments received from Comcast and Verizon, subject to receipt of said funds from Comcast and Verizon in accordance with the applicable Licenses, and subject to availability of funds in accordance with applicable law, in accordance with the following. Payments for PEG Access funding in the second and subsequent years of this Agreement shall be increased relative to the first year payments set forth in Section 7(a)(i) above by an inflation escalator equal to two and one half percent (2.5 percent) per annum.

(iv) In lieu of the Town providing said funding to A-CAM, the Board of Selectmen, may, in its discretion, instruct the cable Licensee, in writing, to make said PEG Access payments directly to A-CAM.

(b) Whereas pursuant to the Prior Agreement the Town transferred to A-CAM for consideration of the exchange of mutual covenants herein and other good consideration all equipment and furnishings purchased or acquired prior to the execution of the Prior agreement by the Town for public access purposes located at Andover High School from Comcast, Verizon, or any other funding source, A-CAM shall continue to hold any such equipment and furnishings, as well as new equipment, furnishings, fixtures and capital assets acquired during the term of this Agreement, in accordance with the terms herein.

(c) A-CAM shall be responsible for the reasonable maintenance and repair of all A-CAM facilities and equipment, including all equipment provided to A-CAM pursuant to Subparagraph (b) above.

(d) If requested by the Town, A-CAM shall, within a reasonable time, not to exceed thirty (30) days provide copies of invoices for and/or inventories (including models and serial numbers) of all equipment, furnishings, fixtures and capital assets acquired and/or owned by A-CAM.

(e) It is further agreed that A-CAM shall be responsible for managing the operation of all existing live municipal (Town and School) broadcast sites listed in Appendix A, attached hereto, (except those municipal sites that may hereinafter be excluded in writing by the Town Manager), including installing, maintaining and replacing as necessary, PEG Access equipment, including cameras and cablecasting equipment, at the Andover Town Offices and other such town and/or school buildings as may hereinafter be designated in writing by the Town Manager. The Town shall be responsible for the cost for the purchase and/or replacement of the equipment for said live municipal broadcast sites, subject to Town prior approval of any purchase of equipment for which the Town is responsible for costs. A-CAM shall not be required to purchase or replace any such equipment unless and until the Town first provides A-CAM with the necessary capital funding for such. A-CAM shall continue to be responsible for maintenance and repair of the PEG Access equipment. The Town Manager and A-CAM shall throughout the term of this Agreement consult regarding such capital needs and requirements. A-CAM shall consult with the Town Manager or its designee prior to purchasing and installing said equipment.

(f) To secure its obligations pursuant to this Section 7 in the event of dissolution or termination of this Agreement, A-CAM hereby grants the Town a security interest in all the assets

and interests acquired or owned by A-CAM as a result of the funding provided pursuant to this Agreement, including, but not limited to, any equipment so provided or purchased and/or any real property obtained from funding provided pursuant to this Agreement. A-CAM agrees to take all steps reasonably requested by the Town to perfect and enforce the Town's security interest, including the execution and processing of financing statements and continuation statements under the Uniform Commercial Code, the inclusion of a mortgage condition acceptable to the Board of Selectmen and/or entering a covenant. A-CAM may request that the Town, through the Board of Selectmen, agree to subordinate its interest if necessary to finance the purchase of equipment or property, including real property. The subordination, if granted by the Board of Selectmen, shall only be with respect to the specific equipment or property that A-CAM might wish to finance. Notwithstanding the foregoing, any exercise of rights under any security interests herein shall be implemented consistent with applicable Internal Revenue Service requirements and other federal and state law with respect to transfer of assets and/or property from a tax exempt charitable corporation to a government unit or tax exempt organization.

(g) Upon the dissolution of A-CAM, the termination of this Agreement and/or the expiration of a cable license(s) by the Town with a cable operator(s) without provision for the continued funding of PEG Access thereafter, A-CAM shall, if requested by the Town, return to the Town or to one or more charitable or educational institutions or organizations selected by the Board of Selectmen and created and organized for nonprofit purposes similar to those of the Corporation (including the operation and management of PEG Access Operations and Programming, which qualify as tax exempt §501(c)(3) of the Internal Revenue Code or the corresponding section of any future federal tax code) all equipment and property, including any real property, provided to A-CAM pursuant to this Agreement or purchased by or for A-CAM from funds provided pursuant to this Agreement and all unexpended funds previously provided to A-CAM pursuant to this Agreement. At the option of the Town said equipment, property (including any real property) and/or funds shall, upon the occurrence of one of the above referenced contingencies, be provided by A-CAM to such organization(s) designated by the Town to manage access, which shall at that time qualify as a tax exempt organization(s) under §501(c)(3) of the Internal Revenue Code or the corresponding section of any future federal tax code.

SECTION 8. ACCESS STUDIO

(a) The Access studio shall comply with all applicable laws and regulations.

(b) When the Access studio is operational, A-CAM shall establish reasonable and regular studio hours, with the specific hours based upon the reasonable needs of Access Users. Throughout the term hereof, the Access studio shall, absent special circumstances, on average, be open to Access Users a minimum of forty hours (40) per week, (including any hours considered for the use of the Andover Public Schools) including some evening and weekend hours, subject to funding as contemplated by this Agreement. A-CAM shall inform the public, through cablecasts on the Public Access Channel, of the days and hours when the studio will be open and available pursuant to the regular schedule and, in addition, if by arrangement upon reasonable request. A-CAM shall inform the Town, in writing, of any non-temporary change in the regular hours of the Access Studio.

(c) The Access studio shall be for the use of Access Users as defined in Section 3, above notwithstanding the use of the access studio and equipment as defined in the agreement between the Andover School Committee and A-CAM which agreement shall be attached and become a part of this contract. The studio shall not be used for any other purpose or for the benefit of any persons other than Access Users or persons whose specific use of the studio benefits PEG Access in Andover, unless otherwise authorized by the Town, through its Town Manager. Implementation of this grant agreement shall be guided by and for the primary purpose of supporting and stimulating the provision of non-profit, non-commercial local programming for the benefit of the general public.

SECTION 9. GOVERNANCE OF ACCESS CORPORATION

The governance of A-CAM shall comply with the By-Laws of the Corporation as of the date hereof, subject to such By-Laws amendments as may be lawfully adopted by the Corporation's Board of Directors. The Town Manager shall be provided not less than thirty (30) days advance notice of and opportunity to comment on amendments to the by-laws, if any, subject to such amendment procedures as otherwise required by applicable law and the Corporation's Bylaws. Directors and officers shall receive no compensation for their services provided as Directors, however, that a Director may be reimbursed for reasonable and necessary expenses incurred subject to and in accordance with any applicable Bylaws and applicable law.

SECTION 10. SEMI-ANNUAL WRITTEN REPORT

A-CAM shall semi-annually, within sixty (60) days of the end of each six month period, provide a reasonably detailed semi-annual report including a budget report of revenues and year-

to-date expenditures to the town, addressed to the attention of the Town Manager, regarding the status of progress with respect to the current and future provision of PEG Access operations and programming in Andover.

SECTION 11. ANNUAL REPORT

At least once each calendar year, A-CAM shall submit to the Town, addressed to the attention of the Town Manager, a written report for the prior year (together with an electronic copy) which shall contain, at a minimum, the following information:

- (a) A summary of programming and services provided;
- (b) List of future goals;
- (c) Current and complete listing of A-CAM's Board of Directors;
- (d) A complete current inventory of all equipment; and

(e) The year-end financial review or audit, prepared for A-CAM. Unless prohibited by applicable law, regulations or accounting standards, A-CAM may have a financial review, rather than an "audit", conducted. A-CAM shall use a "certified public accountant" for a financial review, however, use of a certified public accountant for such financial review may be waived where circumstances warrant, requested in advance and in writing by A-CAM and approved in writing by the Board of Selectmen. However, the Board of Selectmen may in its discretion, where it finds circumstances warrant, require that A-CAM have a financial audit performed by a "certified public accountant", upon timely written notice to A-CAM.

SECTION 12. UPDATE MEETING BETWEEN TOWN AND A-CAM

(a) When requested by the Town Manager or his/her designee, A-CAM shall meet with the Town Manager and/or his/her designee(s) as applicable. The purpose of said meeting shall include reviewing A-CAM's compliance with the terms and conditions of this Grant Agreement, and hearing comments and/or suggestions from the Town and the public.

(b) The Town Manager and/or his/her designee(s) shall have the right to question A-CAM regarding any aspect of its performance under this Grant Agreement. A-CAM shall cooperate with the Town Manager or his/her designee(s), and shall produce, at its cost, such documents or other materials relevant to such review and evaluation as are reasonably requested by the Town, subject to applicable laws and regulations. Members of the public may submit comments during such review hearing, either orally or in writing, at the direction of the Town Manager or his designee.

(c) A-CAM shall provide notice of all such performance evaluation hearings by periodic

messages on the Public Access channel.

(d) Nothing in this Section shall prohibit the Town of Andover from requesting that A-CAM attend other meetings or hearings, or compelling the attendance by A-CAM through any lawful means.

SECTION 13. PERFORMANCE REVIEW BY THIRD PARTY

A-CAM shall, if requested by the Town of Andover through its Town Manager, be required to engage or retain a person or entity that is knowledgeable and experienced in PEG Access operations in the Commonwealth of Massachusetts to conduct a performance review of A-CAM's operations. The cost of the foregoing shall be the responsibility of the Town, subject to A-CAM's participation in determining the scope and nature of such review. Upon completion, A-CAM shall submit a copy of the performance review to the Town Manager.

SECTION 14. RECORDS AND AUDIT

(a) A-CAM shall maintain all necessary books and records, in accordance with generally accepted accounting principles. Additionally, A-CAM shall:

- (i) implement effective internal financial and operating controls for the efficient use of all funds and other resources provided pursuant to this Grant Agreement;
- (ii) maintain all necessary books and records, in accordance with generally accepted accounting principles;
- (iii) have a year-end financial review or audit as set out in Section 11e.
- (iv) make timely payment as due to persons and entities supplying labor, materials or services to A-CAM for any purpose under this Grant Agreement; and
- (v) maintain generally accepted business and accounting practices with respect to its operations and investments, financial oversight and management.

(b) Upon request from the Town, A-CAM shall, at a reasonable time(s) during normal business hours, make available any or all of its records with respect to all matters covered by this Grant Agreement.

(c) The Town shall, at its cost, have the right to have the financial books and records of A-CAM Access reviewed by a qualified individual or firm. Nothing herein shall be deemed to diminish the responsibility of A-CAM, if any, under applicable law or regulation, with respect to any financial record keeping or financial statement and/or audit requirements. Copies of any such

financial records, statements or audits shall be provided to the Town upon request of the Issuing Authority.

(d) All capital equipment, assets and fixtures (including furniture) obtained by A-CAM will be inventoried and permanently marked, and an inventory, including invoice numbers, maintained and updated.

SECTION 15. INDEPENDENT CONTRACTOR

It is understood and agreed that A-CAM is an independent contractor and that no relationship of principal/agent or employer/employee exists between the Town and A-CAM. If in the performance of this Grant Agreement any third persons are employed by A-CAM, such persons shall be entirely and exclusively under the control, direction and supervision of A-CAM. All terms of employment, including hours, wages, working conditions, discipline, hiring and discharging or any other term of employment shall be determined by A-CAM and the Town shall have no right or authority over such persons or terms of employment. A-CAM shall retain the right and power to determine the details of implementation of any objectives or requirements herein to the extent necessary to act as an independent contractor.

SECTION 16. ASSIGNMENT AND TRANSFER

Neither this Grant Agreement nor any interest or responsibility herein shall be assigned or transferred by A-CAM, except as expressly authorized in writing by the Town through its Town Manager.

SECTION 17. FUNDING FROM OTHER SOURCES

Nothing in this Grant Agreement shall prohibit A-CAM from obtaining funding from other sources in a lawful manner, including, but not limited to, fundraising activities.

SECTION 18. INDEMNIFICATION

A-CAM shall indemnify, defend (through the provision of counsel in accordance with the provisions below), and hold harmless the Town, its officials, employees, volunteers and agents from and against any and all claims, suits, actions, causes of action, losses, damages, or liabilities of any kind, nature or description (including payment of reasonable attorneys' fees and litigation costs and expenses reasonably incurred by the Town prior to the provision of qualified legal counsel by A-CAM or its insurer for the Town as required herein, but only after the provision of

written notice of such indemnification event by the Town to A-CAM) brought by any person or persons for or on account of any loss, damage or injury to person, property or any other interest, tangible or intangible, or death sustained by or accruing to any person or persons, howsoever the same may be caused or arising or resulting from any alleged act(s) or omission(s) of A-CAM, its officers, employees, volunteers, agents or subcontractors from or with respect to the performance of this Grant Agreement or arising from or in connection with any claims, loss or damage to person or property arising out of the failure to comply with any applicable laws, rules, regulations or other requirements or orders of local, state or federal authorities, for claims of libel, slander, invasion of privacy, or infringement of common law or statutory copyright, or for breach of contract or other injury or damage in law or at equity which claims result from A-CAM's use of channels, funds, equipment, facilities or staff granted under or obtained pursuant to the funding from this Grant Agreement. The Town shall give the A-CAM written notice of its (A-CAM's) obligation to indemnify and defend the Town of a claim for which indemnification is sought. As to any matter arising under this indemnity provision, A-CAM or its insurer shall have the right to select qualified counsel of its choice, subject to any requirements of legal representation under applicable law, to represent the Town and above referenced Town indemnities hereunder. This indemnification requirement shall survive the termination or expiration of this Grant Agreement. As to any matter arising under this indemnity provision, the Town reserves its right to select its own counsel, other than the counsel selected by and paid for by A-CAM or its insurer, subject to the Town paying costs for same. In the event that A-CAM has actual notice of a claim against the Town based on A-CAM acts or omissions, or based on acts or omissions of A-CAM's officers, employees, volunteers, agents or subcontractors, A-CAM shall notify the Town of such claim.

SECTION 19. INSURANCE

A-CAM shall, unless otherwise directed in writing by the Town, obtain and maintain in full force and effect at all times during the term of this Grant Agreement all insurance required below by this Section.

(a) *Commercial General Liability Insurance* - Commercial general liability insurance policy, including protective liability, completed operations and broad form contractual liability, property damage and personal injury coverage, with a minimum coverage limit of One Million Dollars (\$1,000,000) per person and per occurrence, Two Million Dollars (\$2,000,000) aggregate.

(b) *Motor Vehicle Liability Insurance* - Automobile liability insurance for owned, leased or rented motor vehicles in the amount of One Million Dollars (\$1,000,000) combined single limit.

(c) *Excess/Umbrella Liability Insurance* - In the minimum amount of Two Million Dollars (\$2,000,000) over the insurance required by Subparagraphs (a) and (b) above.

(d) *Business Personal Property Insurance* - Business personal property insurance for facilities and equipment in the amount of replacement cost.

(e) *Workers' Compensation* - Workers Compensation in the minimum amount of the statutory limit if and when A-CAM has an employee.

(f) *Cablecaster's Errors and Omission Insurance* - The Access Corporation shall obtain errors and omission insurance to cover the content of productions which are cablecast on an Access Channel to include, at minimum, the following areas: libel and slander; copyright or trademark infringement; infliction of emotional distress; invasion of privacy; plagiarism; misuse of musical or literary materials. This policy shall not be required to cover the personal liabilities, if any, of individual Access producers, however, the policy shall cover the liability of the Access Corporation and Town if and to the extent any such personal producer liability falls on the Access Corporation and/or Town. The minimum amount of said insurance shall be One Million Dollars (\$1,000,000). In furtherance of the foregoing, it shall be the responsibility of the Access Corporation to require that individual producers and users execute user forms assuming responsibility for their own acts and omissions in connection with cablecasting and producing programming.

(g) The following conditions shall apply to the insurance policies referenced above:

- (i) The Town shall be named as an additional insured on all aforementioned insurance coverages to the extent allowed by law, other than the workers' compensation policy and Cablecaster's Errors and Omission Insurance. The policies shall provide that no cancellation, material change in coverage or expiration may be affected by the insurance company or A-CAM without first giving the Town thirty (30) days (or the maximum lesser time period as may be obtained, in the event that a 30-day notice is not commercially available) written notice prior to the effective date of such cancellation or change in coverage;
- (ii) Such insurance shall be primary with respect to any insurance or self-insurance maintained by the Town and shall not call on the Town's insurance for contributions;
- (iii) Such insurance shall be obtained from producers authorized to transact insurance business in the Commonwealth of Massachusetts and, unless otherwise agreed

to in writing by the Town, shall be provided by an insurance carrier(s) licensed to do business for the coverage provided in the Commonwealth of Massachusetts by the Massachusetts Division of Insurance;

- (iv) The coverage amounts set forth above may be met by a combination of underlying and umbrella policies so long as in combination the limits equal or exceed those required herein and follow the same form;
- (v) The cost of such insurance, including all premiums and deductibles, shall be borne by A-CAM;
- (vi) The parties shall periodically review the insurance coverage and coverage amounts required above to determine whether said insurance adequately protects the parties and is cost effective given available funding pursuant to this Grant Agreement;
- (vii) The failure of A-CAM to maintain the insurance required herein shall be grounds for the Town to suspend this Grant Agreement immediately, without resort to the termination procedures provided in Section 21 below; and
- (viii) If the Town's own minimum coverage amount for any of the insurance referenced above is higher than that required herein of A-CAM or otherwise increases, the Issuing Authority may require A-CAM to increase its corresponding insurance coverage within twelve (12) months written notification by the Issuing Authority to A-CAM, unless such increased insurance coverage is commercially unavailable to A-CAM.
- (ix) The General Liability policy shall include a Waiver of Subrogation in favor of the Town

(h) *Directors' and Officers' Liability Insurance* - A-CAM shall obtain directors' and officers' liability insurance for its directors and officers, if commercially available.

(i) *Tenant Legal Liability* - Tenant legal liability insurance in the amount of One Hundred Thousand Dollars (\$100,000). This insurance may be obtained by A-CAM as part of its Commercial general liability insurance policy. The Town may waive this requirement as deemed warranted based on the commercial availability and cost of this insurance.

(j) The coverage amounts set forth above may be met by a combination of underlying and umbrella policies, so long as in combination the limits equal or exceed those required herein.

SECTION 20. COMPLIANCE WITH LAWS AND REGULATIONS

A-CAM shall be governed and operated in accordance with applicable laws and regulations.

SECTION 21. TERMINATION OF AGREEMENT .TRANSFER OF ASSETS

(a) The Town, through its Board of Selectmen, shall have the right upon ninety (90) days written notice to A-CAM to terminate this Grant Agreement for the following, subject to A-CAM first having reasonable written notice of the alleged grounds for termination, and subject to A-CAM first having a reasonable opportunity to be heard with respect to same, and having a reasonable opportunity to cure any such matter, subject to paragraph (b) below:

- (i) Malfeasance, misfeasance, misappropriation or waste of funds provided pursuant to this Grant Agreement;
- (ii) Loss of 501(c)(3) status by A-CAM;
- (iii) A-CAM filing a petition of bankruptcy, or for receivership or reorganization, has filed any other petition under the bankruptcy law, or has taken or committed an act preparatory to the filing of any such petition, has become insolvent or has committed any other act of bankruptcy or insolvency, or has a substantial portion of its assets assessed for the benefit of creditors, however, in the event of a bankruptcy filing, or other bankruptcy-related action as above, no termination shall occur if inconsistent with the requirements of a bankruptcy stay or if inconsistent with other bankruptcy law or court orders or;
- (iv) The loss of a substantial portion of PEG Access funding as a result of: a change in the financial terms of a cable license; a change in the status of a cable service provider; or a change in law; or
- (v) For any material breach of a material provision of this Grant Agreement by A-CAM.

(b) A-CAM may avoid termination by curing any such breach within forty-five (45) days of written notification or such longer time as the Board of Selectmen determines. Upon a third material breach by A-CAM over the course of a twenty-four (24) month period, the Town may terminate the Grant Agreement upon written notice provided without any cure period as long as said notice is provided within sixty (60) days after the material breach (each day a material breach continues shall be deemed to be an actionable day for purposes of this requirement to terminate within said 60-day period).

(c) A-CAM shall have the right upon sixty (60) days written notice to the Town to terminate this Grant Agreement for material breach of any material provision of this Grant Agreement by the Town. The Town may avoid termination by curing any such breach within said sixty (60) day period.

(d) All written notices of termination shall include a reasonably detailed description of the alleged breach.

(e) See Section 19(g)(vii) for immediate suspension or termination as a result of A-CAM's failure to maintain the required insurance.

(f) See Section 7(f) and (g) above regarding security interests, return of funds, return of equipment, real property, fixtures, contracts, leases, deposit accounts or other assets received by or purchased by A-CAM with funds received pursuant to this Grant Agreement.

SECTION 22. MISCELLANEOUS PROVISIONS

Section 22.1 Entire Agreement

This instrument contains the entire agreement between the parties, which supersedes all prior agreement(s) between the parties or proposals except as specifically incorporated herein, and cannot be changed orally but only by an instrument, in writing executed by the parties.

Section 22.2 Cooperation

Each party agrees to cooperate with the other party to carry out the provisions of this Grant Agreement.

Section 22.3 Captions

The captions to sections throughout this Grant Agreement are intended solely to facilitate reading and reference to the sections and provisions of the Grant Agreement. Such captions shall not affect the meaning or interpretation of the Grant Agreement.

Section 22.4 Liability of Town Officials and Employees

To the fullest extent permitted by law, no official, employee, agent or representative of the Town or A-CAM shall be individually or personally liable on or for any obligation of the Town or A-CAM respectively, under this Grant Agreement and with respect to obligations of the parties to each other

Section 22.5 Force Majeure

If by reason of Force Majeure either party is unable in whole or in part to carry out its obligations hereunder, said party shall not be deemed in violation or default during the continuance of such inability, provided the party takes immediate and diligent steps to comply as soon as possible under the circumstances with this Grant Agreement without endangering the health or safety of the persons or property. The term “Force Majeure” as used herein shall include, but not be limited to, the following: acts of God; acts of public enemies; orders of any kind of the government of the United States of America or of the State or any of their departments, agencies, political subdivision, or officials, or any civil or military authority, insurrections, riots, epidemics, landslides, lightening, earthquakes, fires, hurricanes, volcanic activity, storms, floods, civil disturbances, explosions, strikes, and unavailability of essential equipment, service or materials, the unavailability of affordable insurance coverage, or other matters beyond the reasonable control of the party. In the event that any such delay in performance or failure to perform affects only part of the party’s capacity to perform, the Licensee shall perform to the maximum extent it is able to do so in as expeditious a manner as possible. The party subject to Force Majeure shall notify the other party in writing of the occurrence of an event covered by this Section within ten (10) business days of the date upon which the party learns of its occurrence as a Force Majeure event.

Section 22.6 Non-Waiver

Failure of either party to insist on strict performance of any portion of this Grant Agreement or to exercise its rights or remedies hereunder upon the failure of performance or default of the other party, shall not be considered a waiver of the right to insist upon or to enforce any provision of this Grant Agreement or to exercise any right or remedy occurring as a result of any future failure of performance or default.

Section 22.7 Severability

If any section, sentence, paragraph, term or provision of this Grant Agreement is determined to be illegal, invalid or unconstitutional, by any court of competent jurisdiction such determination shall have no effect on the validity of any other section, sentence, paragraph, term or provision hereof, all of which shall remain in full force and effect for the term of the Grant Agreement.

Section 22.8 Applicable Law

This Grant Agreement shall be interpreted and enforced under the laws of the

Commonwealth of Massachusetts.

Section 22.9 Notice

Official notice shall be in writing, and delivered or sent by certified mail return receipt requested or express mail signature required. Delivery shall be equivalent to direct personal notice, direction or order, and shall be deemed to have been given at the time of delivery. Certified mail shall be deemed to have been given two (2) days after mailing and express mail shall be deemed to have been given the day after mailing. Notice shall be addressed as provided below or such other name, title and/or address as hereinafter provided in writing by the respective party/

TOWN OF ANDOVER

**ANDOVER COMMUNITY ACCESS
AND MEDIA, INC.**

Town Manager

Executive Director

Andover Town Offices

Andover Community Access and Media Inc.

36 Bartlet Street

80 Shawsheen Road

Andover, MA 01810

Andover, MA 01810

Section 22.10 Successor Parties

References to Comcast and Verizon in this Grant Agreement shall apply to any and all transferees or successors to Comcast and Verizon and such transferees or successors shall be bound by the terms hereof.

IN WITNESS WHEREOF, the parties have executed this Grant Agreement as a sealed instrument as of the date first written above.

TOWN OF ANDOVER

By Town Manager (as authorized by the Board of Selectmen)

_____ date:

APPROVED AS TO FORM

By Town Counsel Thomas J. Urbelis

_____ date:

ANDOVER COMMUNITY ACCESS AND MEDIA, INC.

By its President (as authorized by a vote of its Board of Directors):

_____ date:

APPROVED AS TO FORM

By William Solomon, Special Counsel to A-CAM

_____ date:

Appendix A: Live Broadcast Sites

3 rd Floor conference room or “Selectmen Room” – Town Offices	36 Bartlett Street
School Committee Conference room	36R Bartlett Street
Memorial Hall Library (3 rd floor)	3 Main Street
Safety Center	32 Main Street
Second Floor Conference Room	36 Bartlett Street
Sites to be added in 2018:	
Doherty WWI memorial Auditorium	36 Bartlett Street
Andover / Cormier Youth Center	40 Whittier Ct.

Motion

Move that the Selectmen authorize the Town Manager to execute the renewal grant agreement with Andover Community Access and Media Inc. for a five year period starting January 1, 2018.