





N/F
ANDOVER
APARTMENTS
LLC

N/F
ANDOVER TECHNOLOGY
PARTNERS LLC

N/F
LINCOLN ANDOVER LLC

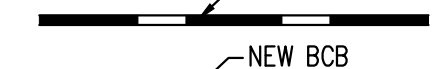
LAYOUT AND MATERIALS LEGEND:

-  NEW BUILDING
-  CRUSHED STONE DRIP STRIP
-  SLOPED GRANITE CURB (SGC)
-  VERTICAL GRANITE CURB (VGC)
-  BITUMINOUS CONCRETE BERM (BCB)
-  RETAINING WALL

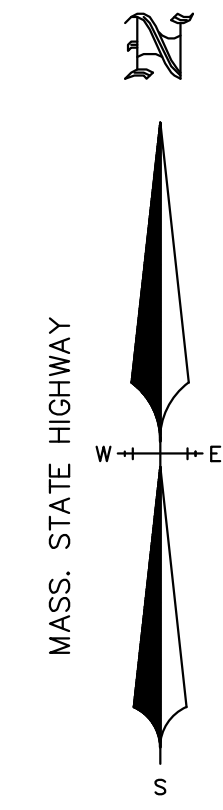

SHATTUCK

N/F ANDOVER
FIVE LLC

FOUR CORPORATE DRIVE

EXISTING TWO STY
BRICK BUILDING
(TO BE RENOVATED)

NEW TWO STORY
ADDITION

LOT A
AREA=1,045,535± S.F.
(24.00± ACRES)

OVERALL SITE PARKING

THE PRESENT SITE HAS PARKING PROVIDED AS FOLLOWS:

A TOTAL OF 258 PARKING SPACES ARE ASSOCIATED WITH THE EXISTING 4 CORPORATE DRIVE BUILDING (RESEARCH/LAB USE). THERE IS A SPECIAL PERMIT FOR THIS NUMBER OF SPACES WHICH IS A PARKING RATIO OF 1.272 SPACES/1000 S.F. (OR 1 SPACE FOR EVERY 785.96 S.F. OF BUILDING AREA.

A TOTAL OF 237 PARKING SPACES ARE ASSOCIATED WITH THE EXISTING 1 CORPORATE DRIVE BUILDING (BUSINESS OFFICE USE). THE PARKING RATIO PRESENTLY IS 3.485 SPACES/1000 S.F. (OR 1 SPACE FOR EVERY 286.87 S.F. OF BUILDING AREA.

THE EXISTING SITE (COMBINED BUILDINGS 1 AND 2) PRESENTLY HAS A TOTAL OF 495 PARKING SPACES.

WITH THE CHANGES PROPOSED BY THE PROJECT THE SITE PARKING WILL BE AS FOLLOWS:

THE PROJECT WILL PROVIDE A TOTAL OF 458 PARKING SPACES TO SERVE BOTH ONE CORPORATE DRIVE AND FOUR CORPORATE DRIVE BUILDINGS. THE PARKING IS DISTRIBUTED AS FOLLOWS:

ADJACENT TO THE 4 CORPORATE DRIVE BLDG.: 250 REGULAR + 8 HANDICAPPED = 258 TOTAL PARKING SPACES

ADJACENT TO THE 1 CORPORATE DRIVE BLDG.: 190 REGULAR + 3 COMPACT + 7 HANDICAPPED = 200 TOTAL SPACES

THE APPLICANT'S REQUEST FOR A NEW SPECIAL PERMIT TO REDUCE THE NUMBER OF PARKING SPACES WOULD PROVIDE THE PROJECT WITH A PARKING RATIO OF 1 PARKING SPACE PER 799.78 S.F. OF GFA. THIS IS A MODEST AND REASONABLE MODIFICATION TO THE CURRENT CONDITION OF THE PROPERTY WITH RESPECT TO PARKING IN LIGHT OF THE CHANGE IN USE FOR THE RENOVATED AND EXPANDED ONE CORPORATE DRIVE BUILDING.



ALL UNDERGROUND UTILITIES ARE NOT SHOWN ON THIS PLAN AND IF ANY ARE SHOWN THEY SHOULD BE CONSIDERED APPROXIMATE ONLY. BEFORE CONSTRUCTION CALL "DIG SAFE" 1-888-344-7233. SOME DATA IS CONFLICTING AND CAN ONLY BE VERIFIED BY EXCAVATION.

NOTE: FOR ALL LAYOUT AND MATERIAL NOTES SEE SHEET C-4
ALL EXISTING PAVEMENTS, CURBING, BERM, WALKWAYS, SIGNS, ETC. WITHIN THE WORK AREA SHALL BE REMOVED PRIOR TO ANY NEW CONSTRUCTION AND PROPERLY DISPOSED OF OFF-SITE.

1 CORPORATE DRIVE PARKING INFORMATION:

PROPOSED PARKING AVAILABLE @ BUILDING 1:

190 REGULAR + 7 HANDICAPPED ACCESSIBLE + 3 COMPACT = 200 SPACES.

4 OF THE HANDICAPPED SPACES AND 10 OF THE REGULAR SPACES WILL HAVE ACCESS TO ELECTRIC VEHICLE CHARGING STATIONS.

NO CHANGES ARE PROPOSED TO THE EXISTING 4 CORPORATE DRIVE PARKING.

3/18/2022	RGC	▲	REVISED PER TOWN COMMENTS
2/15/2022	RGC	▲	ISSUED FOR PERMITTING
DATE	BY	REV#	REVISIONS

CALC. BY:	WAJ
DR. BY:	WAJ
CKD. BY:	RGC/WAJ
APPD. BY:	RGC
JOB NO.:	21055
SCALE:	1" = 40'
DATE:	FEB. 15, 2022

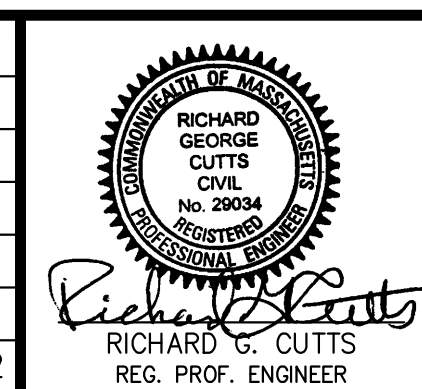

LINDEN ENGINEERING PARTNERS LLC

100 TradeCenter Suite G700
Woburn, MA 01801-1851
Tel: (781) 933-3711
Fax: (781) 287-1277

Civil - Environmental Engineering including
Storm water, Wastewater, Water Supply,
Highway & Infrastructure Design, Land
Planning, Land Subdivision, Site Design,
Environmental Permitting, Wetlands
Permitting & Land Development Permitting

PREPARED FOR:
IQHQ-1 CORPORATE, LLC AND IQHQ-4 CORPORATE, LLC
ATTN: MR. WILLIAM ASHTON
ONE BOSTON PLACE, 201 WASHINGTON STREET, SUITE 3920
BOSTON, MASSACHUSETTS 02108
TEL: (617) 314-7951

**SITE LAYOUT AND MATERIALS PLAN
REQUEST FOR DETERMINATION OF APPLICABILITY
FOUR CORPORATE DRIVE
ANDOVER, MASSACHUSETTS**

**SHEET
C-1**

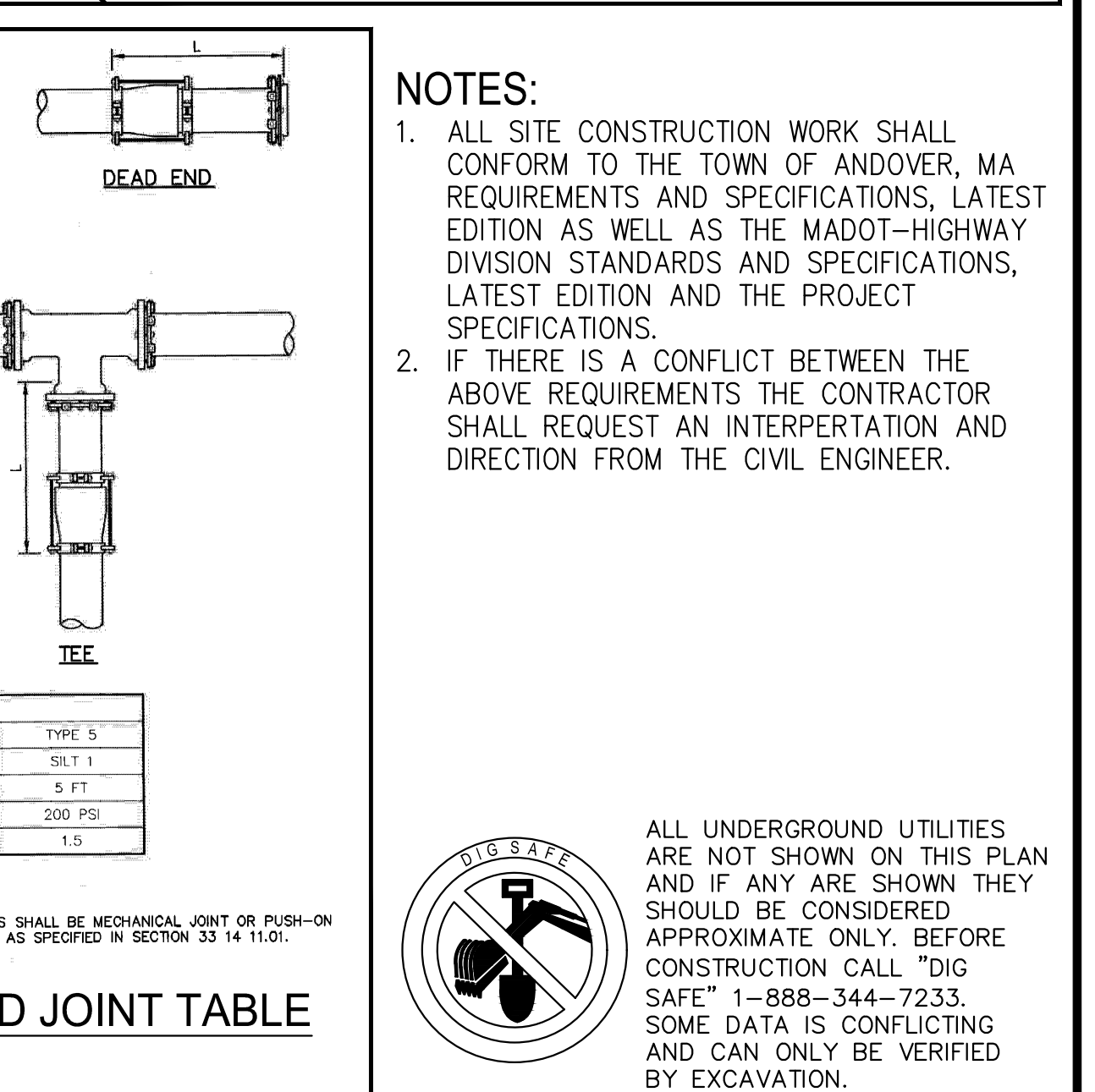
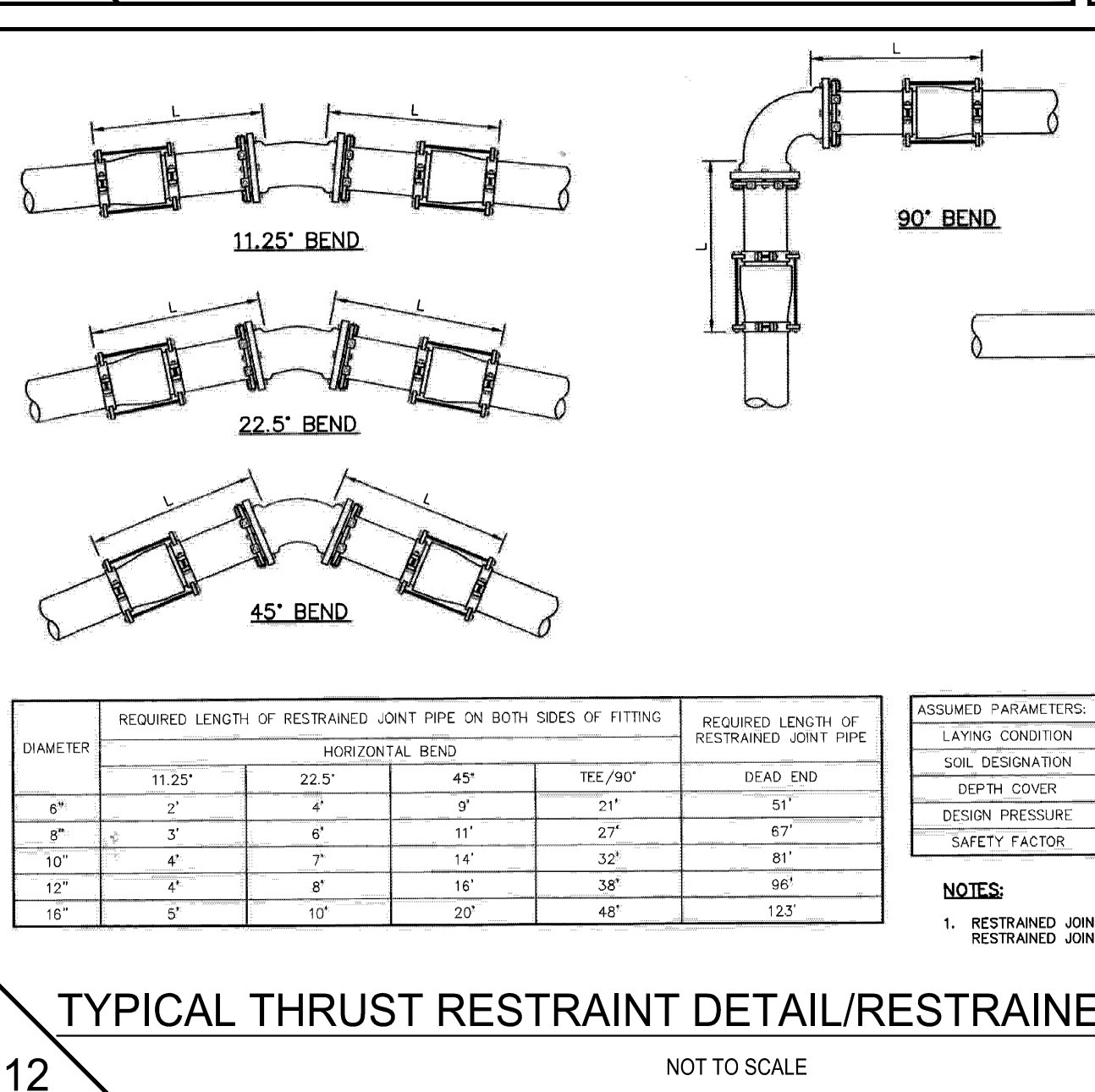
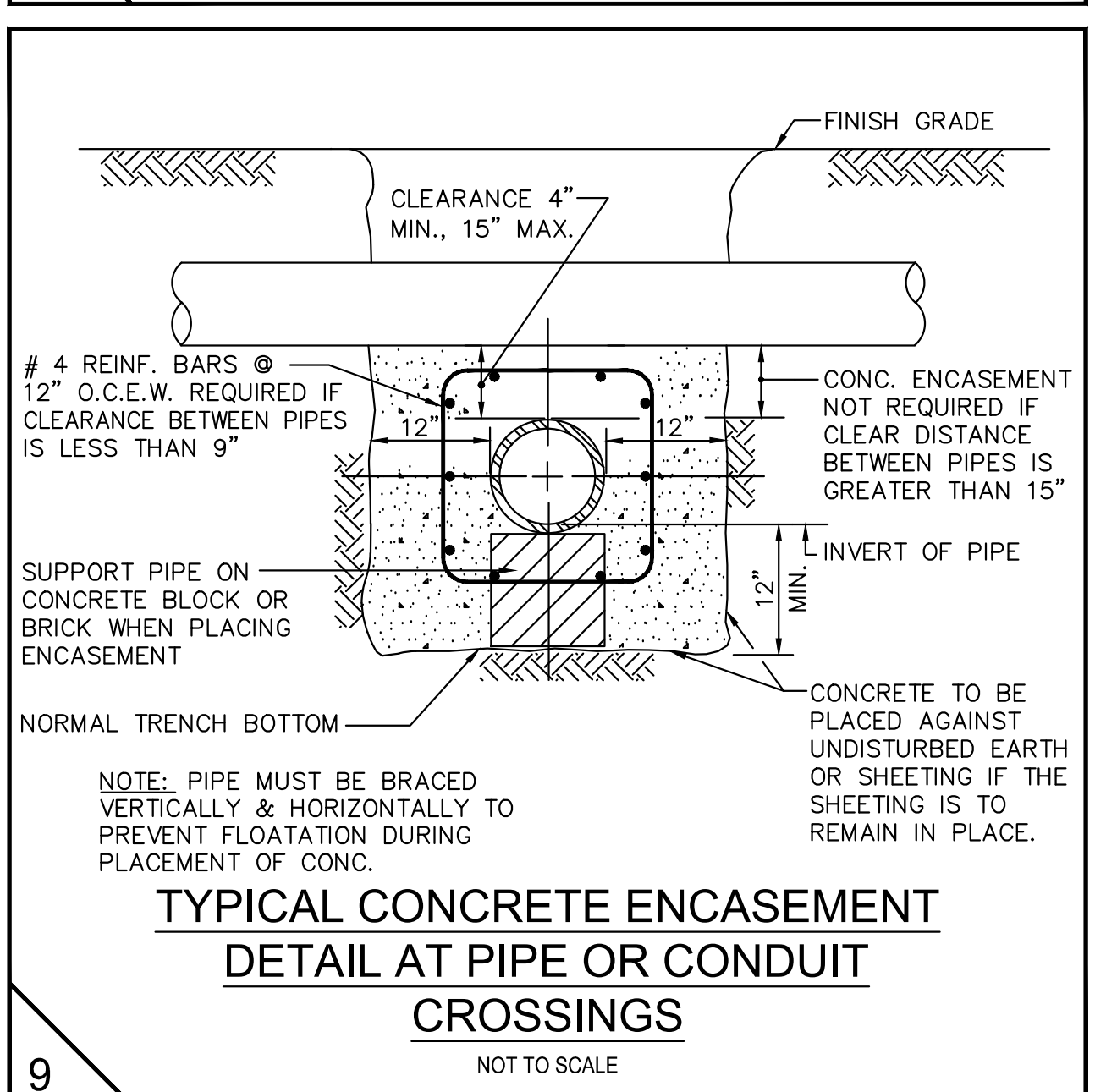
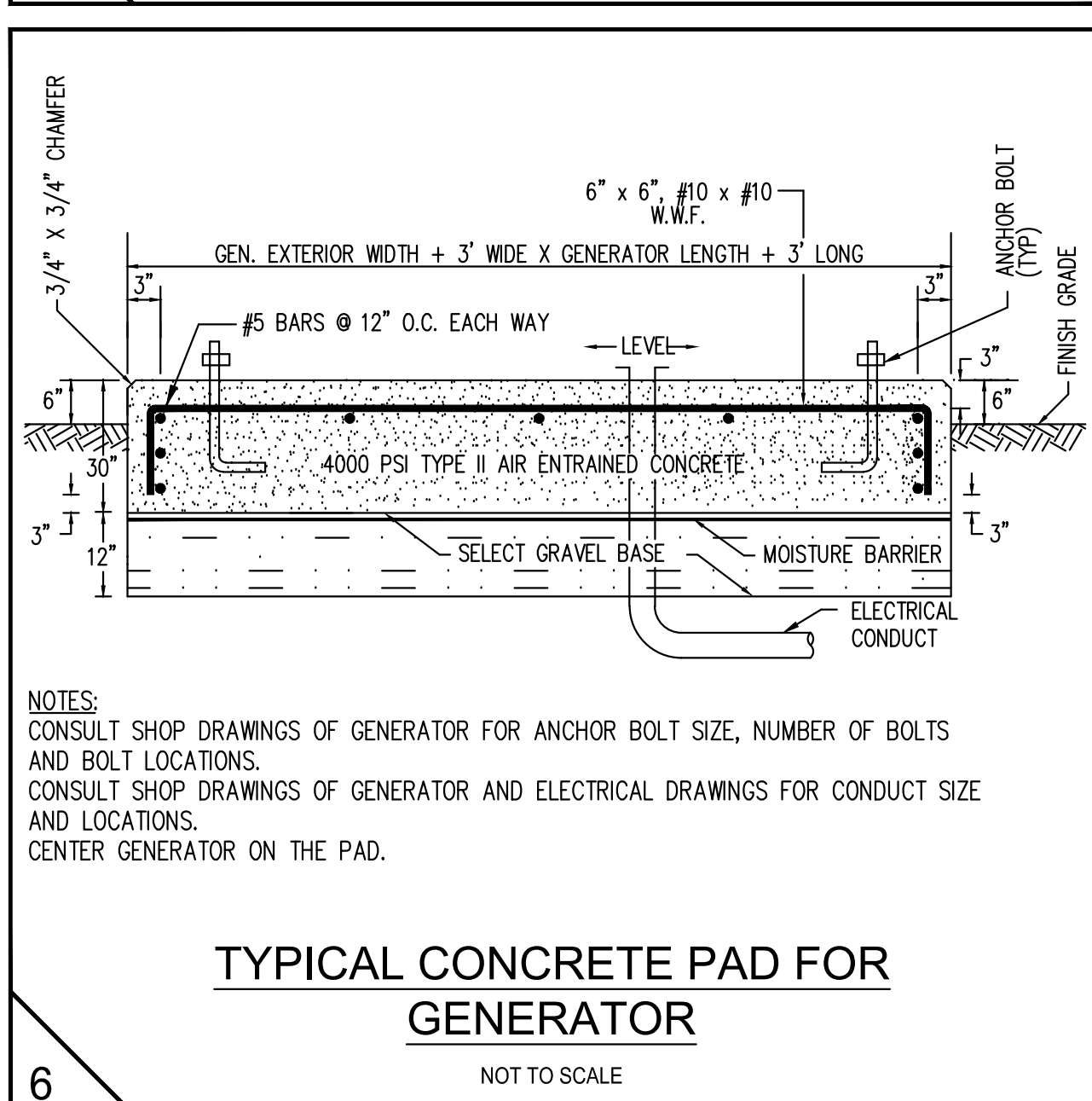
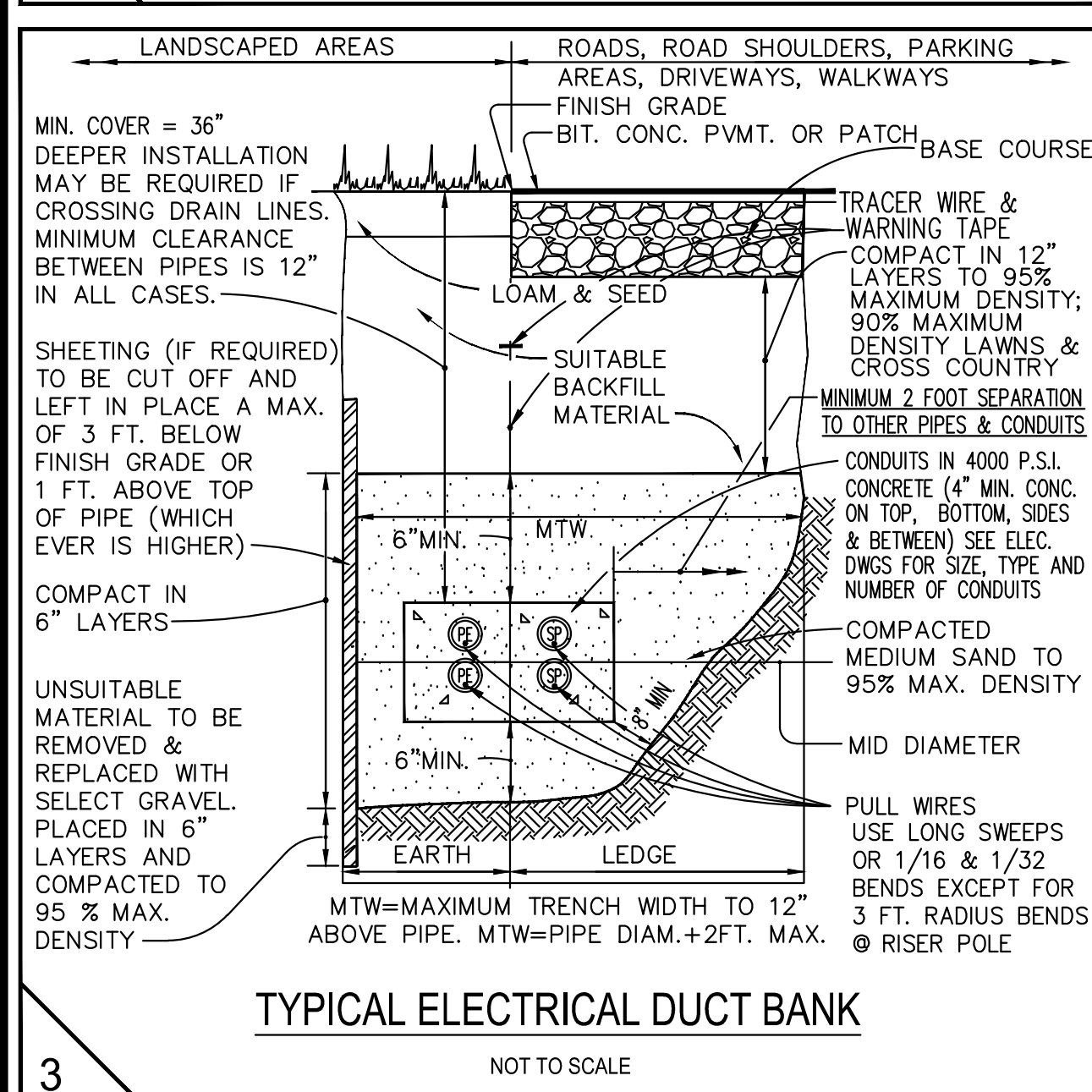
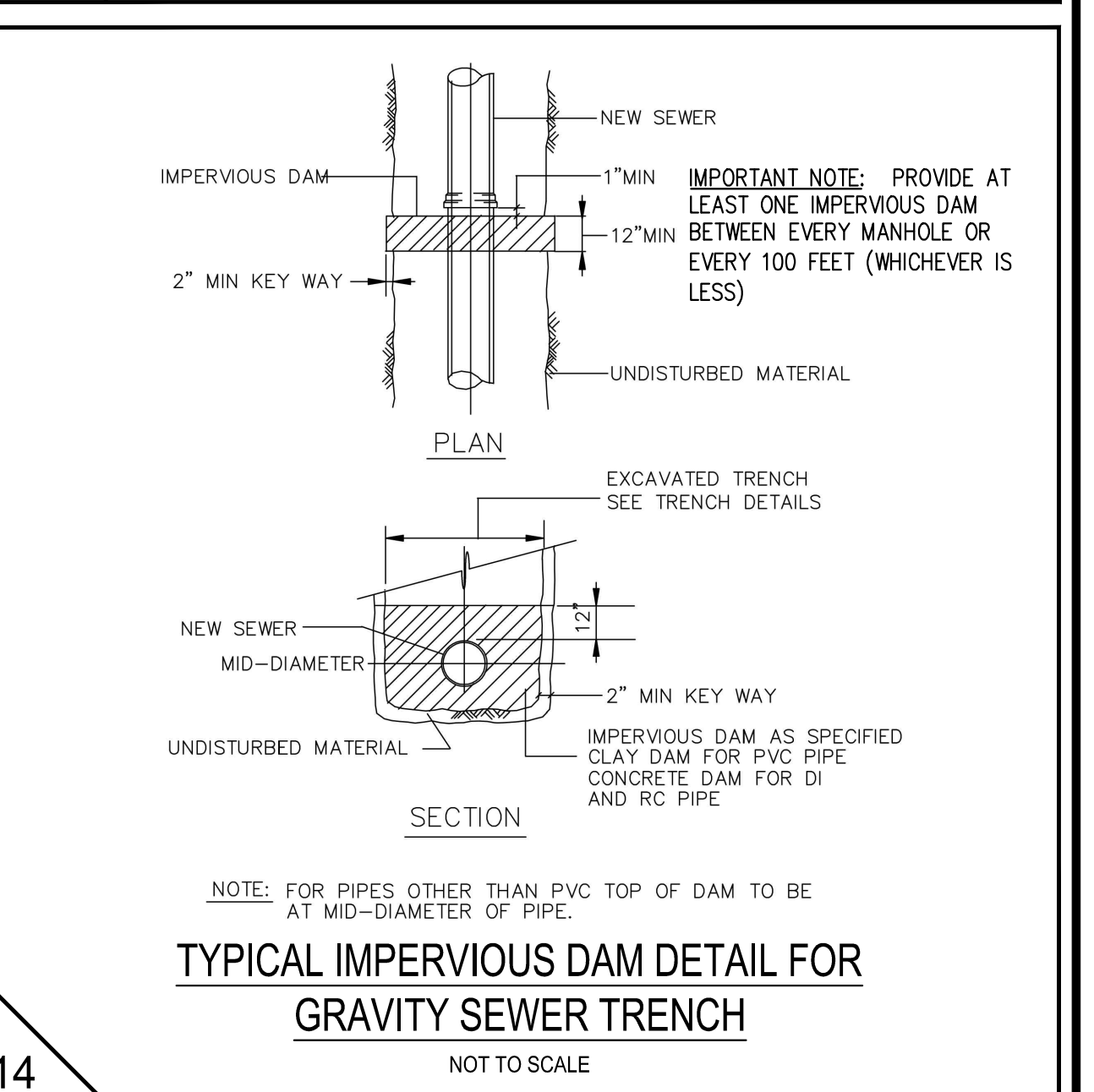
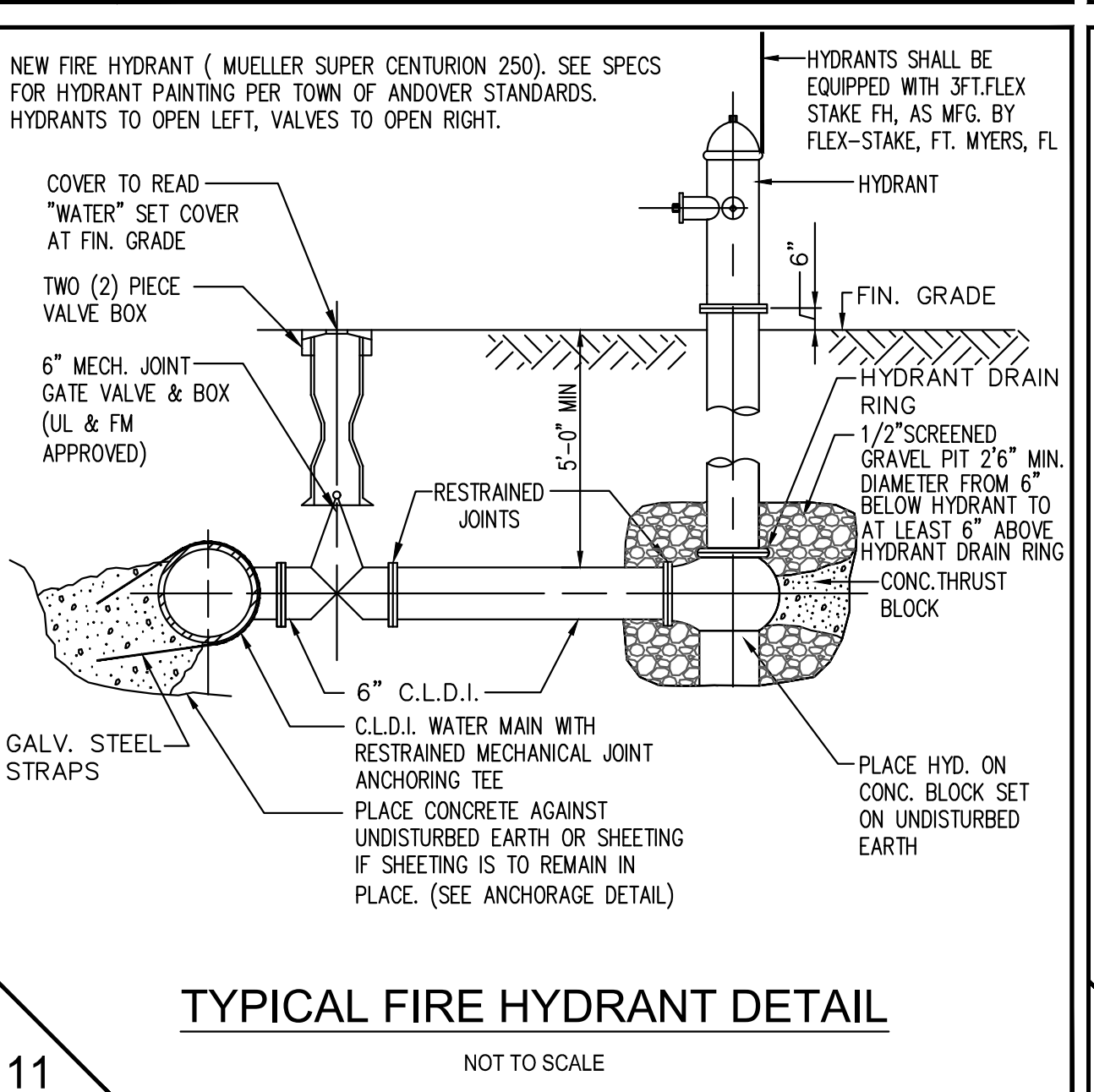
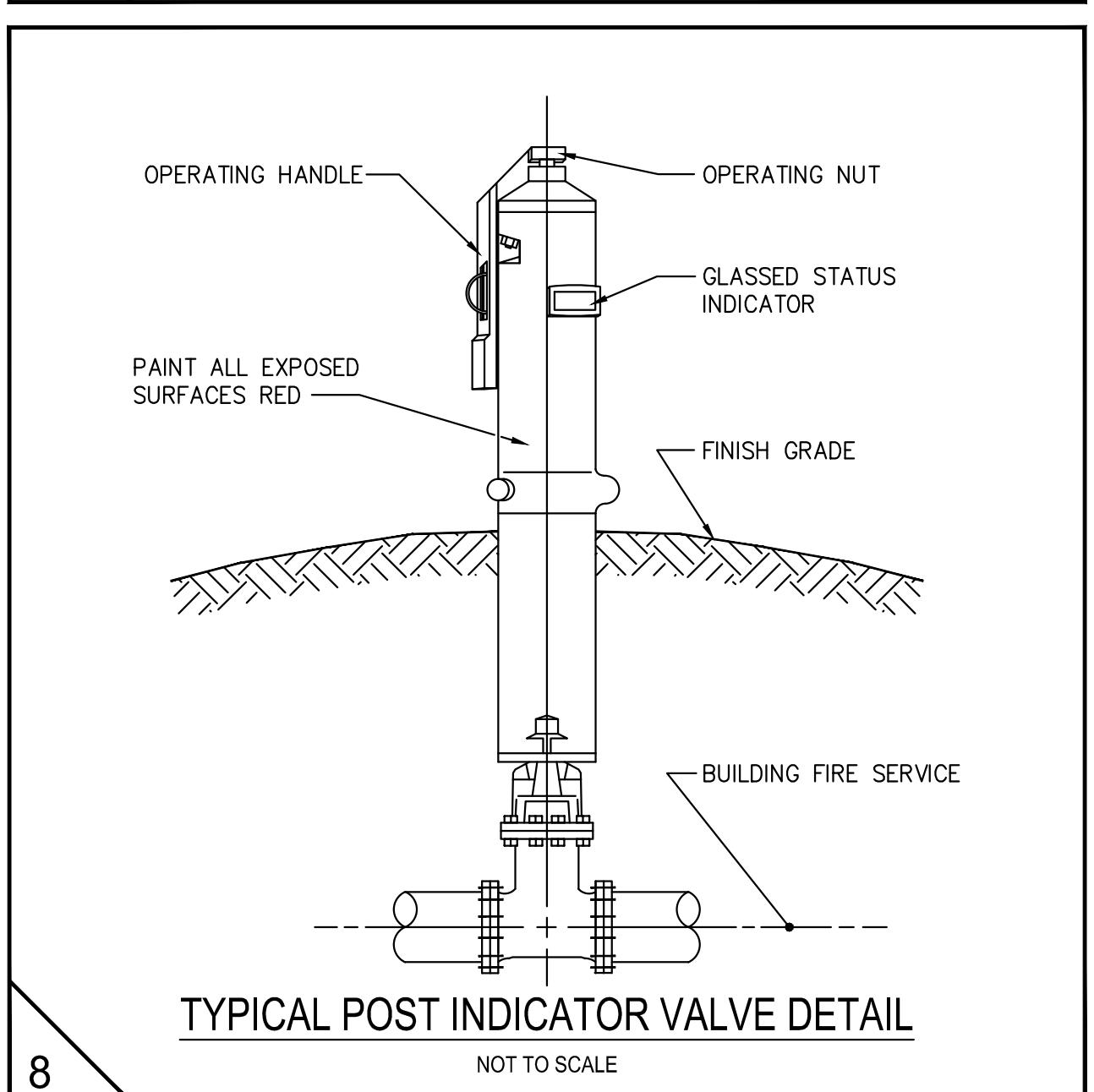
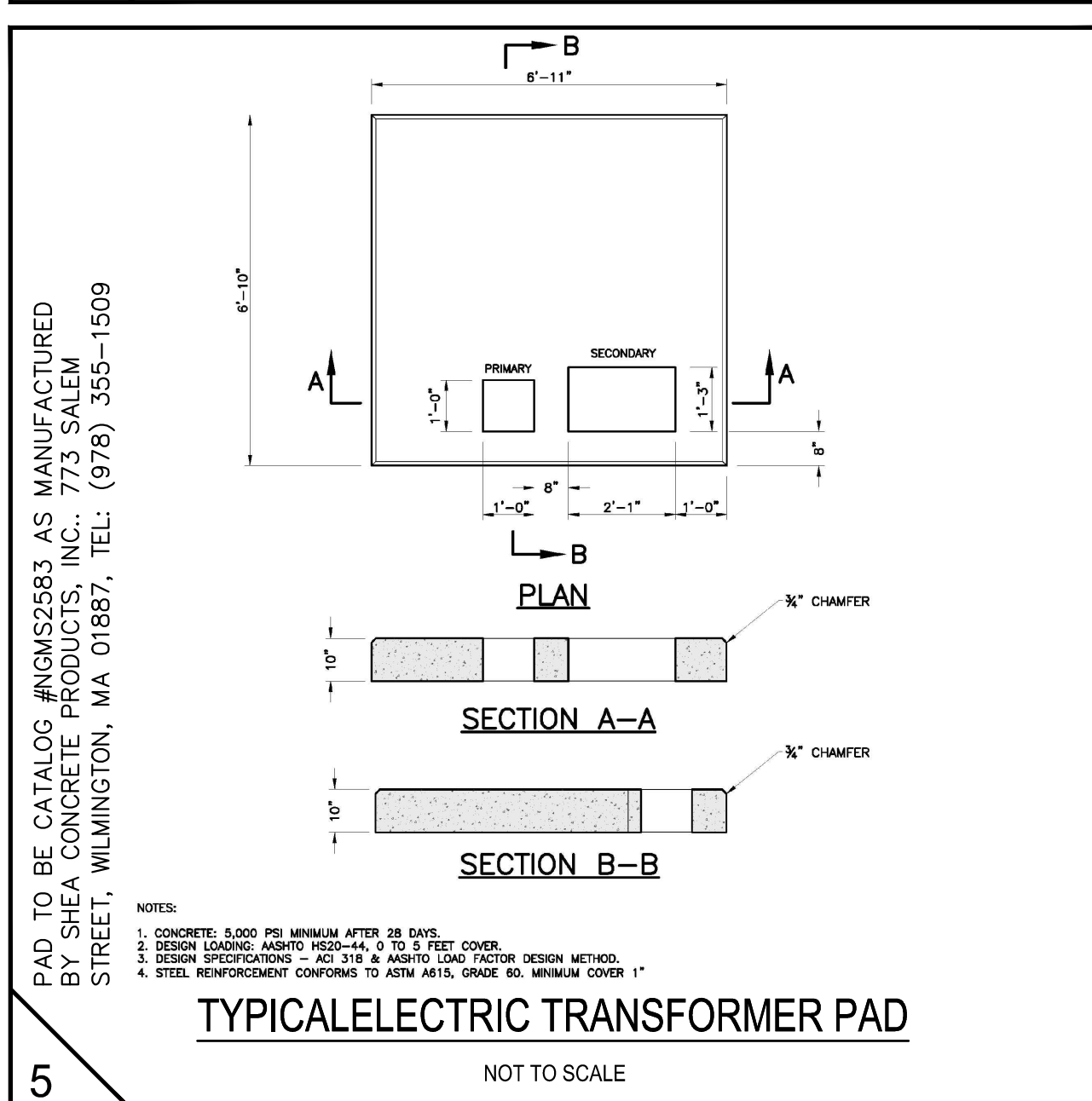
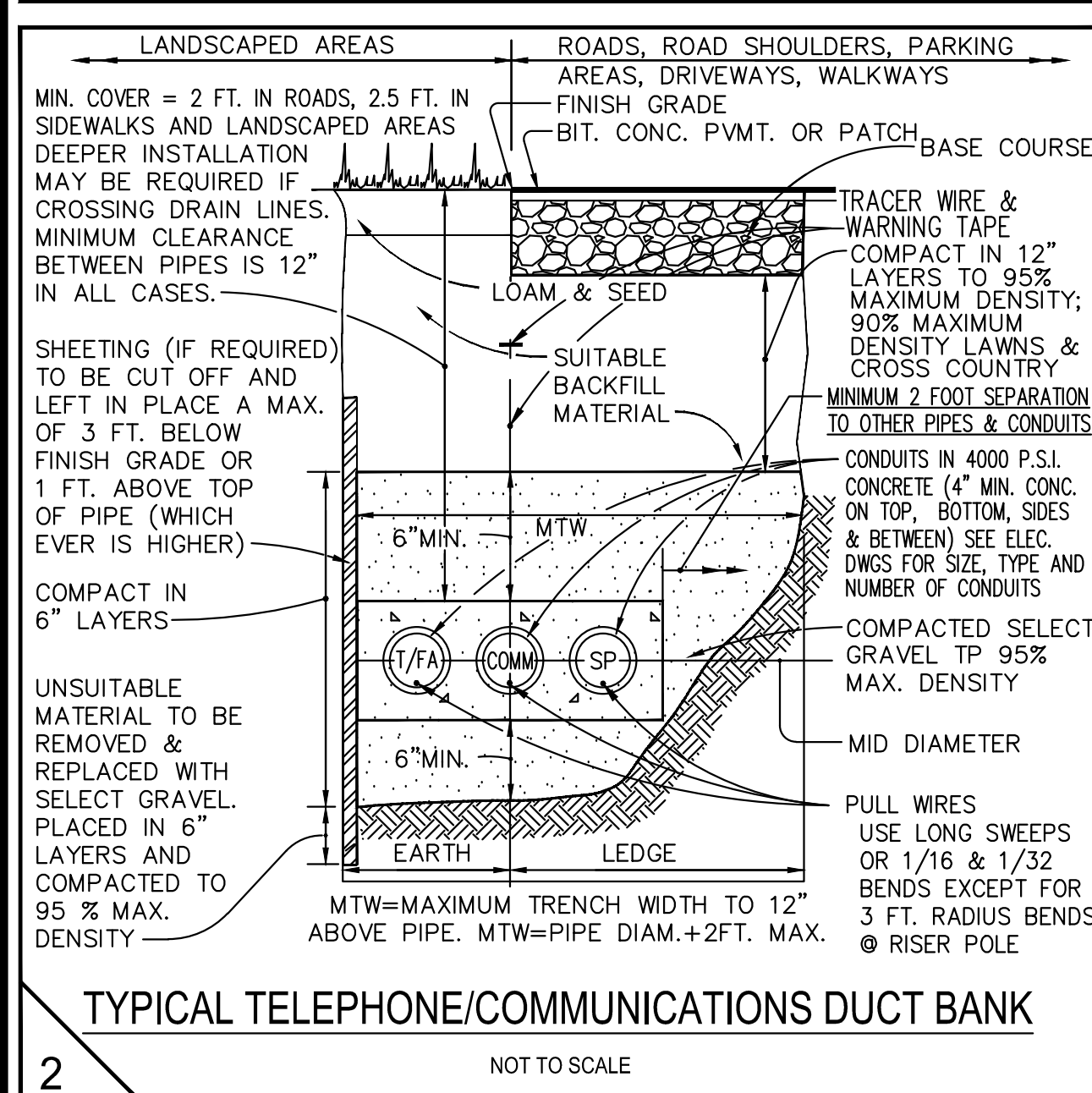
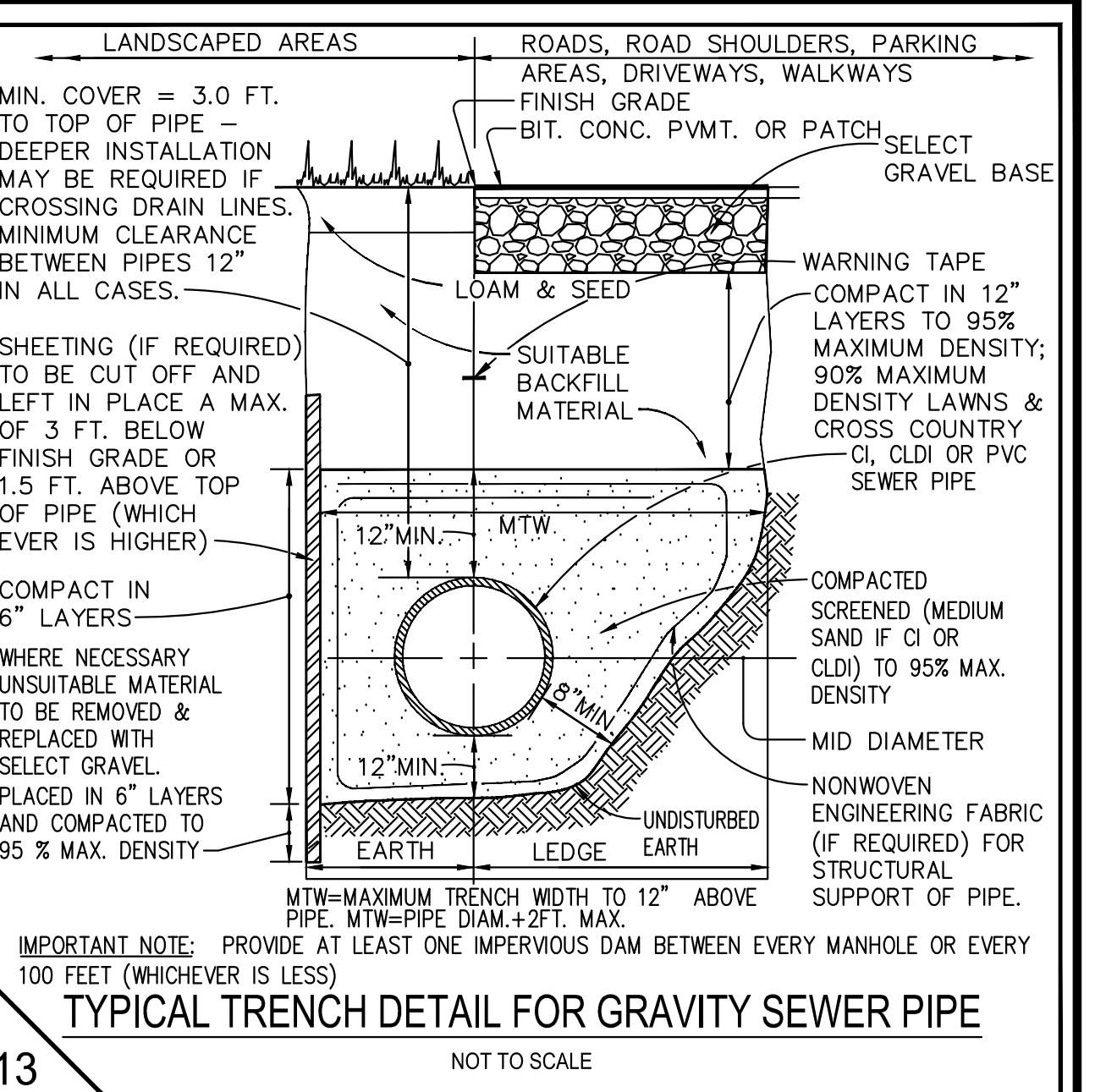
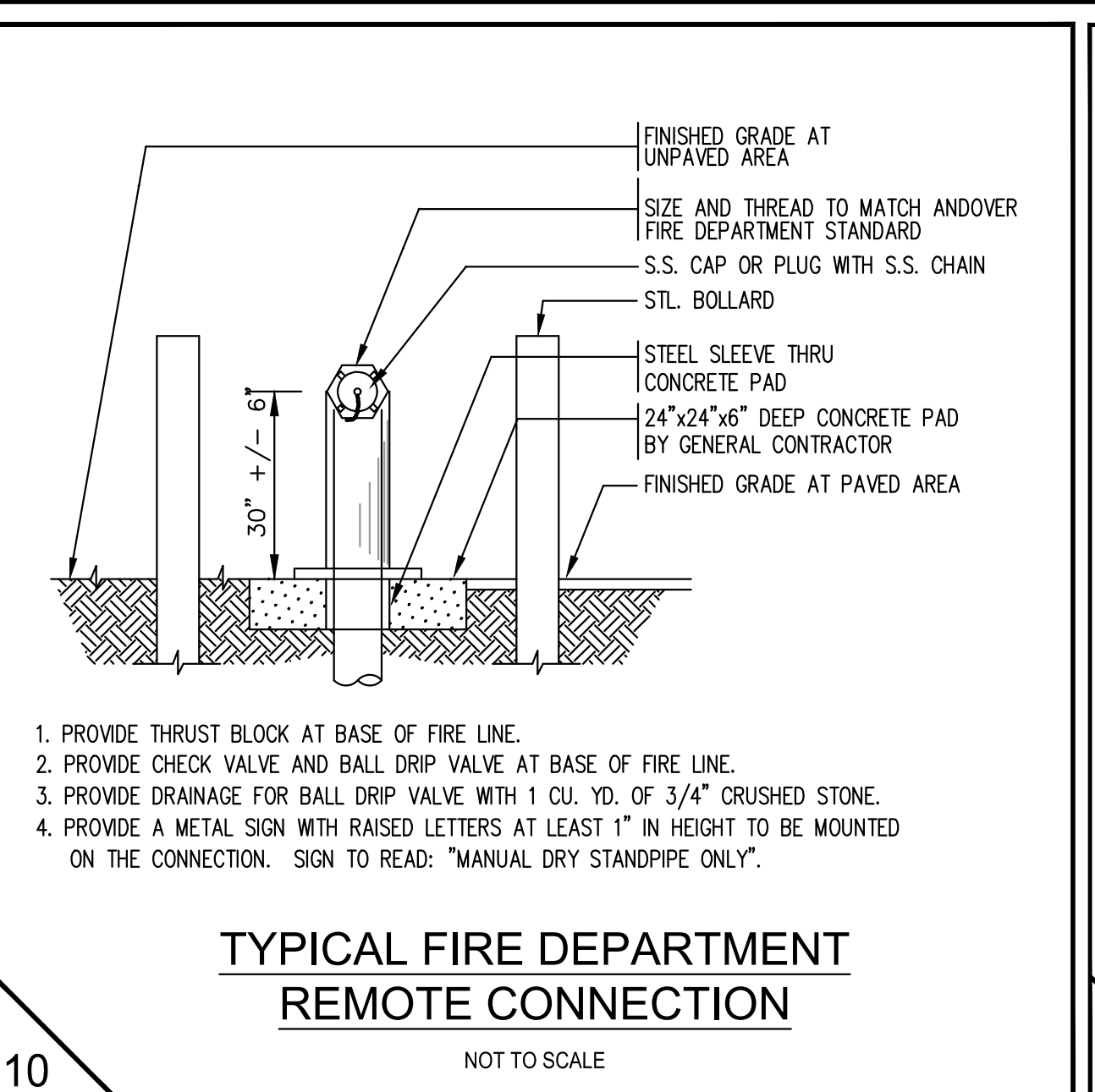
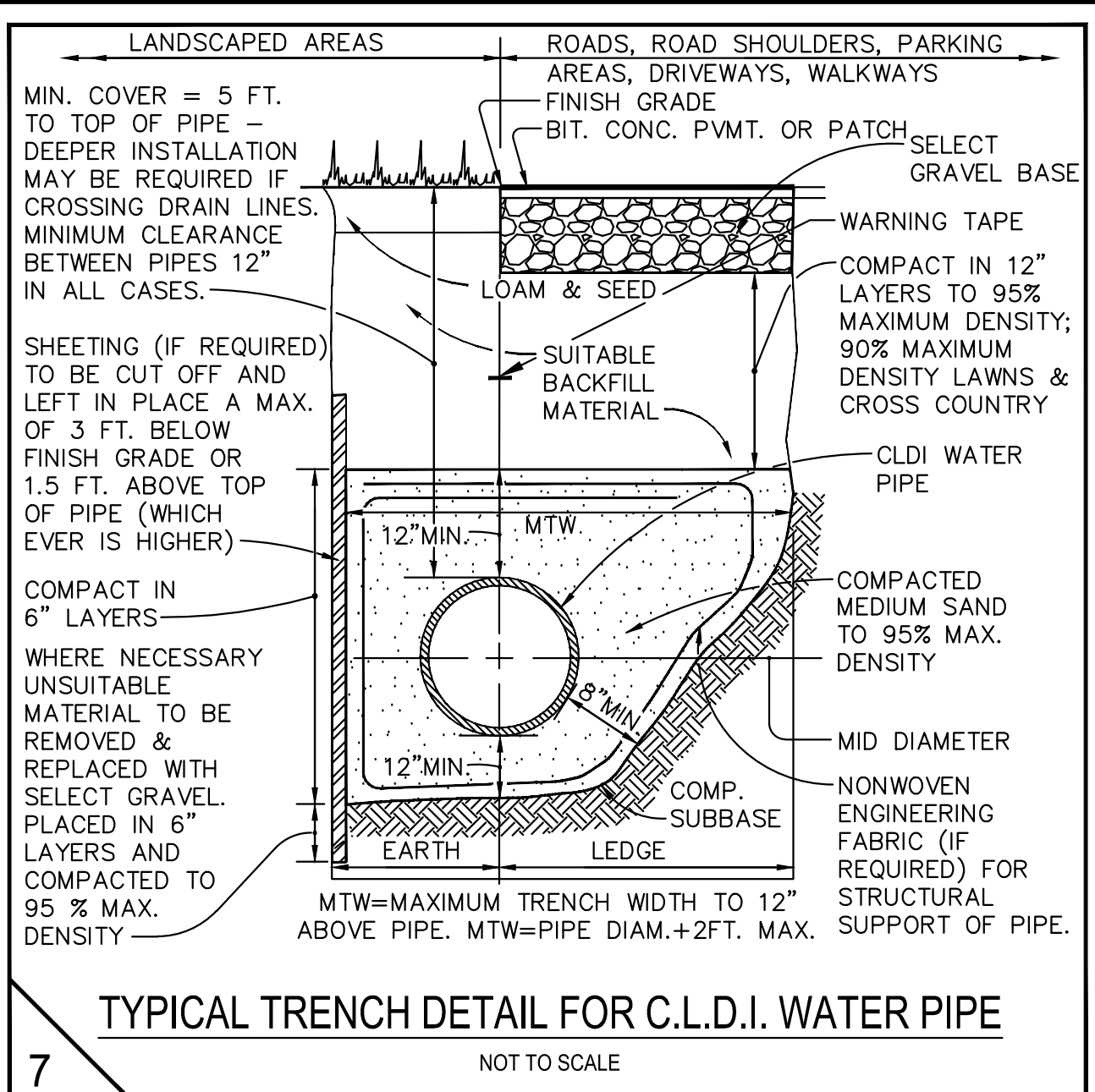
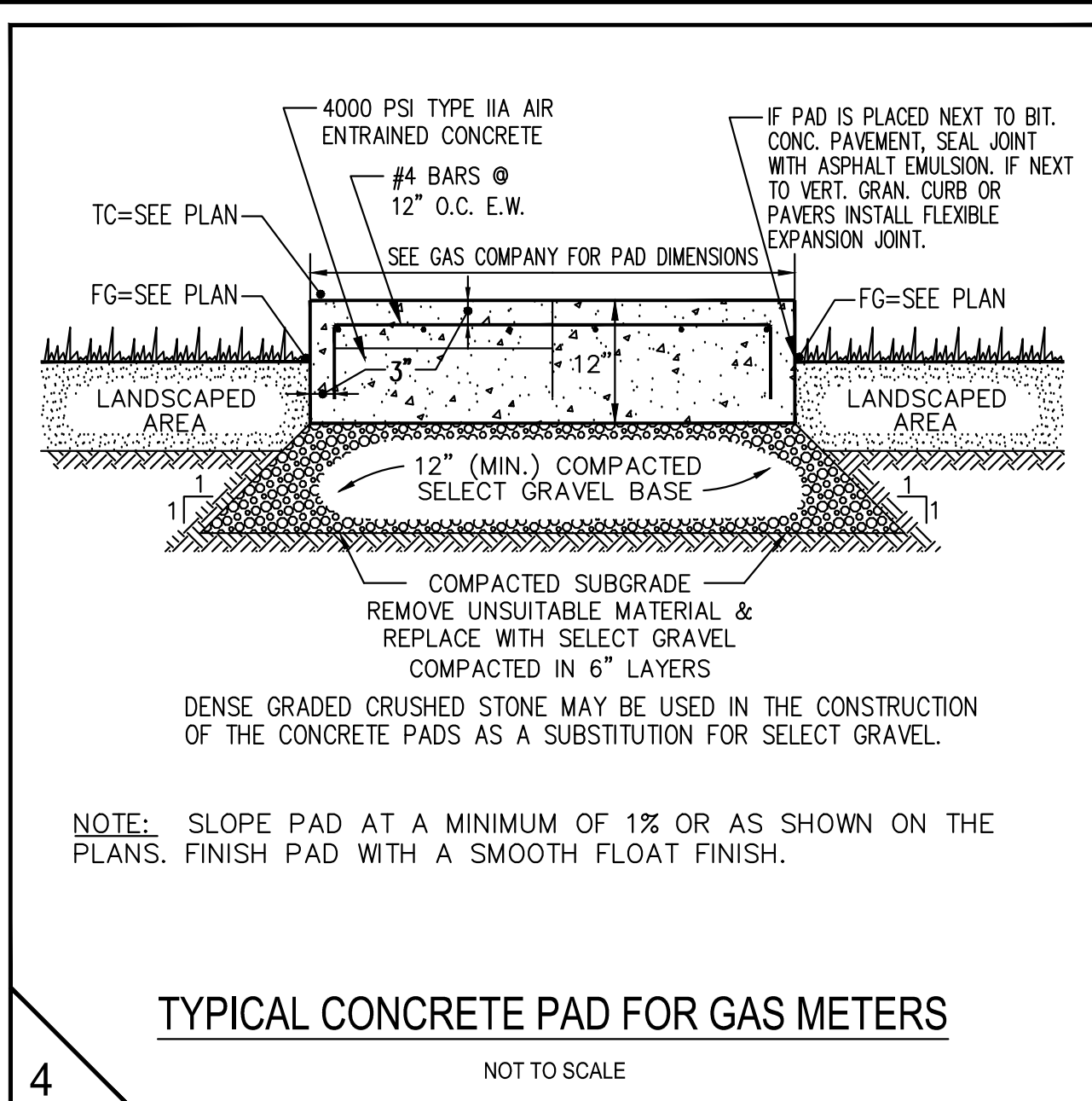
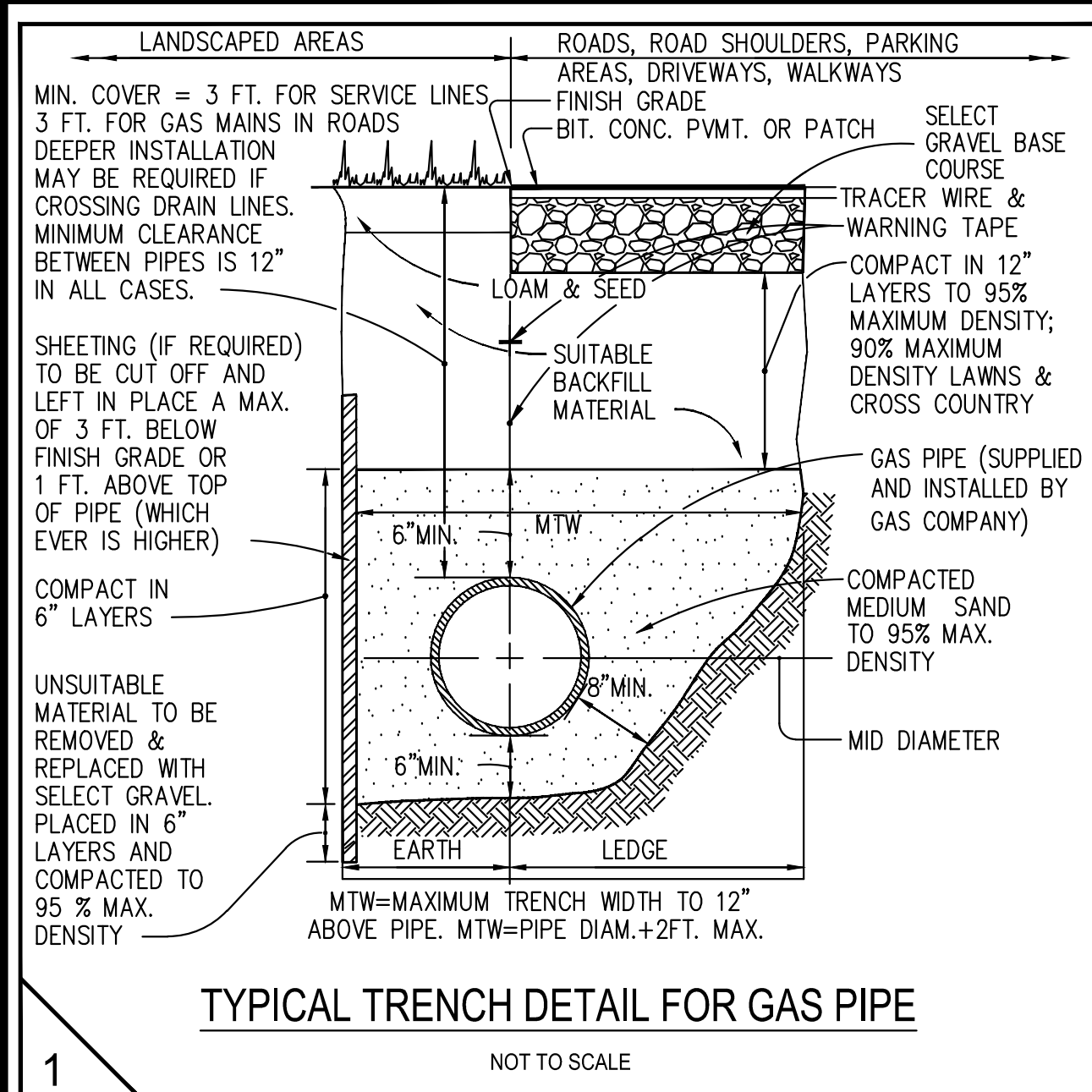

3/18/2022	RGC	△	REVISED PER TOWN COMMENTS
2/15/2022	RGC	△	ISSUED FOR PERMITTING
DATE	BY	REV#	REVISIONS

CALC. BY:	WAJ
DR. BY:	WAJ
CKD. BY:	RGC/WAJ
APPD. BY:	RGC
JOB NO.:	21055
SCALE:	AS NOTED
DATE:	FEB. 15, 2022

LINDEN ENGINEERING PARTNERS LLC
 100 TradeCenter Suite G700
 Woburn, MA 01801-1851
 Tel: (781) 933-3711
 Fax: (781) 287-1277

PREPARED FOR:
 IQHQ-1 CORPORATE, LLC AND IQHQ-4 CORPORATE, LLC
 ATTN: MR. WILLIAM ASHTON
 ONE BOSTON PLACE, 201 WASHINGTON STREET, SUITE 3920
 BOSTON, MASSACHUSETTS 02108
 TEL: (617) 314-7951

CONSTRUCTION DETAILS
 REQUEST FOR DETERMINATION OF APPLICABILITY
 FOUR CORPORATE DRIVE
 ANDOVER, MASSACHUSETTS