

**TECHNICAL REPORT IN SUPPORT
OF A SPECIAL PERMIT**

**11 LEWIS STREET
ANDOVER, MASSACHUSETTS**

**NOVEMBER 15, 2023
REVISED ON FEBRUARY 20, 2024**

SUBMITTED TO:

**TOWN OF ANDOVER
PLANNING BOARD
36 BARTLETT STREET
ANDOVER, MA 01810**

APPLICANT:

**ANDOVER TOWN YARD, LLC
231 SUTTON STREET, SUITE 1B
NORTH ANDOVER, MA 01845**



TECHNICAL REPORT

Table of Contents

DRAINAGE REPORT NARRATIVE		Page
I.	Executive Summary	1
II.	Existing Site Description	1
III.	Proposed Site Description	2
IV.	Stormwater Management	2
	A. Existing Watershed Characteristics	2
	B. Proposed Watershed Characteristics	3
	C. Hydrologic Analysis	3
	D. Stormwater Management Standards	5
V.	Conclusion	6

FIGURES

- Figure 1: Ortho Map
- Figure 2: USGS Locus Map
- Figure 3: SCS Soils Map
- Figure 4: FEMA Flood Map

APPENDICIES

- APPENDIX A MassDEP Stormwater Management Report Checklist
- APPENDIX B Existing Conditions Hydrologic Analysis Report
- APPENDIX C Proposed Conditions Hydrologic Analysis Report
- APPENDIX D Construction Phase Best Management Practices Plan
- APPENDIX E Long Term Best Management Practices O&M Plan
- APPENDIX F Illicit Discharge Compliance Statement
- APPENDIX G TSS Removal Calculations
- APPENDIX H Soil Boring Logs
- APPENDIX I Brochures
- Appendix J References and Sources

DRAINAGE REPORT

Town Yard Development

I. Executive Summary

Andover Town Yard, LLC, the applicant, proposes to construct a multi-family residential building at 11 Lewis Street in Andover, Massachusetts (“site”). The project will include 164 residential units, commercial lease space, indoor amenity space including a public amenity building, public park space including an fenced in dog park, public parking spaces, private garage parking, landscaping improvements, stormwater management system and new utility infrastructure. The subject parcels consist of an aggregate land area of 4.125± acres and are shown on the Town of Andover Assessor’s Map 38 as Lots 4, 15, 16, 32A and 35 which are situated in the Single Residence A, Mixed Use and General Business Zoning District. All the parcels are located within the Historic Mill Overlay District (HMD).

The project will require Site Plan Approval, HMD Special Permit and Stormwater Permit through the Andover Planning Board. As part of the project permitting, the proponent must demonstrate compliance with applicable stormwater best management practices and regulations. The following drainage report contains a description of existing and proposed site conditions, stormwater management design methodology and results summaries and other supplemental information in support of the stormwater best management system design.

II. Existing Site Description

The site consists of a total land area of 179,690 square feet (4.125± acres) and is a combination of five lots. The primary development parcel known as the “Town Yard” is the former Andover Department of Public Works site that consists of four (4) commercial buildings, material stockpile areas, gas filup station and accessory buildings. The Town Yard site is mostly paved. Areas that are not paved consist of compacted gravel and open land. It is mostly devoid of vegetation. The Town Yard parcel is under a land disposition agreement between the applicant and the Town of Andover. 122 North Main Street and 35 Pearson Street consist of single family dwellings and are owned by the applicant. 2-4 Buxton Court and 7 Lewis Street consist of two-family dwellings and are owned by the applicant. The residential lots are fully developed with the dwelling, driveways and open yard areas, typical for the use. The five (5) lots shall collectively be referred to as the “site” herein.

The site contains 5 curb cuts, one on North Main Street, two on Pearson Street, one at the end of Buxton Ct and one at the end of Lewis Street. The site is bordered to the south by residentces, a preschool and home businesses along Pearson Street, the Andover Public Safety Center to the southeast, to the east by residential uses along Buxton Court and to the west by the MBTA Railroad. Refer to Figure 1: Ortho Map and Figure 2: USGS Locus Map for illustrations of the site and surrounding features.

Existing infrastructure on the site consists of an 8” water main which loops from Pearson Street to Lewis Street, drainage infrastructure which extends under the railroad to the west, a 6” sewer which extends down Buxton Court and under the railroad to the west, electric, communications and natural gas. These utilities were identified through a combination of public and private utiltiy records research, on the ground survey of the site and CCTV inspections of the gravity sewer systems. There are no stormwater management mitigation and treatment systems present on the site other than shallow catch basin sumps.

Grades on the site vary from 1.5% on the property south by Pearson Street curb cut, to 10.5% near curb cut on end of Lewis Street, to 20% on north portion, on lot with frontage to North Main Street. The site has a high elevation of approximately 118 (southeast corner of the site at Buxton Ct.) and low elevation of approximately 92 (northwest area near MBTA property line).

Soils on site is mapped as Urban land, Hydrologic Soil Group (HSG) B (602) according to the National Resource Conservation Service (NRCS) soil maps; Soil testing and soil boring information confirms the presence of approximately 4 feet of fill throughout the site. Beneath the fill, the native soil consists of a loamy sand “till” with bedrock varying in depth from 8 feet or greater below the ground surface. See Figure 3: SCS Soils Map for an illustration of the soil types.

The entire site is shown to be within a Zone X, area inundated by 500-year flooding according to the FEMA Federal Insurance Rate Map (FIRM) #25009C0217F, dated July 3, 2012 (See Figure 4: FEMA Flood Map). There are not restrictions to development within a zone x.

III. Proposed Site Description

The applicant proposes to construct a 165-unit multifamily residential building with associated parking, landscaping, stormwater management system and new utility connections and maintain the existing single-family dwelling on North Main Street. The project will also include an accessory public amenity building with a small commercial space, public parking, public and private park areas including a fenced in public dog park. All site improvements will comply with the Massachusetts Architectural Access Board (MAAB) for handicap access.

The multifamily residential building will be constructed of a combination of steel and wood up to 5 stories on the west side and 4 stories on the east side along Buxton Court. Parking will be provided beneath the entire building, including landscaped plazas on portions of the garage roof around the building. The footprint area of the building is 69,300± square feet. The accessory commercial and amenity building has a footprint area of 2,710± square feet will be constructed just south of the residential building. Drive aisles and surface parking are also proposed with a curb cut located on Pearson Street and another from Buxton Court. Additional public parking is proposed along frontage on Pearson Street.

Infrastructure associated with the development of the site will include the removal and replacement of the existing water, drainage, overhead-electrical and sewer services and construction of stormwater management infrastructure with other associated utilities including domestic water and fire protection services, natural gas, electrical, communications and fiber optic services. New utility connections will extend from Buxton Court and Pearson Street, with fire hydrants provided. The water main will be looped between Pearson and Buxton Court along the site driveway.

The proposed stormwater management system for the project will consist of various Best Management Practices (“BMP’s”) in both mitigating and renovating stormwater runoff. The entire stormwater system was designed in accordance with the Town of Andover’s Stormwater Management and Erosion Control Regulations and the Massachusetts Stormwater Management Handbook (“Handbook”), which the Town of Andover references in its regulations. The measures to be implemented at the site includes a subsurface infiltration system utilizing Cultec Recharger 360HD, CDS water quality units and a Jellyfish Filter for phosphorous mitigation. Refer to the Grading & Drainage Plan and associated construction details for more information. The existing watershed characteristics, flow paths and drainage patterns were matched to the extent practicable in the proposed condition to demonstrate that there are no adverse impacts to adjacent properties at the design points.

IV. Stormwater Management

A. Existing Watershed Characteristics

Stormwater runoff exits the site in the existing condition at two (2) distinct locations. The location where stormwater runoff leaves the site boundary is called the design point (“DP”). DP1 is the existing double catch basin carrying water offsite under Pearson Street. DP2 is the western corner of the site where water flows onto Route 1. The design points and the tributary watersheds (or subcatchments) are illustrated on Sheet C-2.2 Pre-Development Watershed Plan. The table below lists the total area associated with each subcatchment area.

Summary of Existing Subcatchments

Existing Drainage Area (E)	Total Area (SF)	% Impervious	Composite Curve Number
ES-1	300,300	69.29%	88
ES-2	13,496	62.41%	84
Total	313,796 (7.20 acres)	68.99%	88

Description of Existing Subcatchments

The subcatchments analyzed in the existing condition can be described as follows:

- **Subcatchment ES1:** This area consists of the majority of the site, including off-site, Lewis Street, Buxton Court, woods behind the existing dwelling off North Main Street, all parking area and building roofs. The stormwater runoff from these areas drain to the MBTA property and end up in the public drainage system on Railroad Street.
- **Subcatchment ES2:** This subcatchment includes only the frontage of the site along Pearson Street and part of Pearson Street. It contains paved parking areas, landscaped areas and building roof. Stormwater from this area sheet flow west to the existing catch basins into the public drainage system.

B. Proposed Watershed Characteristics

The proposed development of the site will maintain the design points identified in the existing watershed analysis. In order to understand and analyze the proposed development, smaller subcatchments were delineated to analyze stormwater impacts on more detailed scale. The table below provides the total drainage area and the percentage that will be impervious in the post-development condition. The design points and the tributary watersheds (or subcatchments) are illustrated on Sheet C-5.2 Post Development Watershed Plan. The table below lists the total area associated with each subcatchment area.

Summary of Proposed Subcatchments

Proposed Drainage Area	Total Area (SF)	% Impervious	Composite Curve Number
PS-1	245,672	70.84	91
PS-1.1	58,367	65.93	88
PS-2	9,957	87.30	96
TOTALS	313,796 (7.20 acres)	70.43%	90

Description of Proposed Subcatchments

- **Subcatchment PS-1:** This area consists of some off-site areas that include the residential properties between North Main Street and Buxton Court, Lewis Street and Buxton Court, and the all southern piece of the development, to include building roofs, new road, courtyard area and pathway connecting Buxton Court to the Courtyard area.
- **Subcatchment PS-1.1:** This area consists of the northern proposed parking lot, dog park and part of the off-site area to include residential properties between North Main Street and Buxton Ct.
- **Subcatchment PS-2:** This area includes the southern parking lot, off of Pearson Street, the proposed curb cut and Pearson Street.

C. Hydrologic Analysis:

The purpose of the stormwater analysis is to demonstrate that the proposed development will not adversely impact the land or surrounding land. The industry standard for stormwater management design in Massachusetts is governed by the Massachusetts Stormwater Management Handbook (“Handbook”)

published by the Mass Department of Environmental Protection, January 2008. The Town of Andover Stormwater Management and Erosion Control Bylaw and associated Regulations provide additional requirements including analyzing the 2, 10, 25 and 100-year storm events.

The Handbook lists 10 standards covering both mitigation and renovation of stormwater runoff. A full discussion on compliance with the standards can be found at the end of this report. However, the following section will summarize the projects compliance with the mitigation standards 1 and 2 of the Handbook relating to reducing peak rates of runoff and creating no adverse down gradient impacts.

In order to demonstrate that there will be no downstream impacts as a result of the proposed project, a stormwater analysis was performed using the U.S. Soil Conservation Service (S.C.S) method of analysis contained in Technical Release #20 (TR-20) published by the U.S. Conservation Service, along with the extreme precipitation values published by the Northeast Regional Climate Center. The software application HydroCAD was used to analyze the existing and proposed development watershed conditions. This application is widely used in the civil engineering industry and is an accepted means of performing a TR-20 analysis. It is a computer aided design program for analyzing the hydrology and hydraulics of storm water runoff. It utilizes the latest techniques of both fields to accurately predict the consequences of any given storm event. This analysis allows the engineer to verify that a given drainage system is adequate for the area under consideration and further allows the engineer to predict where flooding or erosion are most likely to occur. This model was used to analyze the storm drainage system designed for the development to demonstrate that the drainage system is in compliance with the Town’s Stormwater Management Standards.

The HydroCAD analysis was performed by examining the two design points that were previously referenced. The following is a listing of the total existing and proposed development rates and volume of stormwater runoff for the proposed development for the 2, 10, 25 and 100-year rainfall events:

DP1 Peak Discharge Rates (CFS)				
Storm Event		Existing Conditions	Proposed Conditions	Change in Peak
2-yr	Outflow	15.7	15.7	0
10-yr	Outflow	28.7	28.6	-0.1
25-yr	Outflow	36.7	36.4	-0.2
100-yr	Outflow	49.0	48.9	-0.1

DP2 Peak Discharge Rates (CFS)				
Storm Event		Existing Conditions	Proposed Conditions	Change in Peak
2-yr	Outflow	0.6	0.6	0
10-yr	Outflow	1.2	1.1	-0.1
25-yr	Outflow	1.5	1.3	-0.2
100-yr	Outflow	2.1	1.7	-0.4

DP1 Volume (CF)				
Storm Event		Existing Conditions	Proposed Conditions	Change in Volume
2-yr	Outflow	49,076	51,450	2,374
10-yr	Outflow	92,053	95,696	3,643
25-yr	Outflow	119,622	123,863	4,241
100-yr	Outflow	162,901	167,945	5,044

DP2 Volume (CF)				
Storm Event		Existing Conditions	Proposed Conditions	Change in Peak
2-yr	Outflow	1,854	2,203	349
10-yr	Outflow	3,688	3,693	5
25-yr	Outflow	4,888	4,624	-264
100-yr	Outflow	6,790	6,066	-724

D. Review of Stormwater Management Standards

The proposed development project is comprised of a mix of new development and redevelopment. The drainage system has been designed to attenuate peak rates of stormwater for all storm events up to and including the 100-year event. Measures will also be implemented to provide the required total suspended solids (TSS) removal where practicable, to ensure the stormwater runoff is renovated prior to discharge. A waiver will be required in order to meet Standard 4. The following is an assessment of each Standard as it relates to the proposed multi-family residential development project:

1. No stormwater conveyance system discharges untreated stormwater directly to or cause erosion in wetlands or waters of the Commonwealth.

The proposed development meets this standard. All stormwater runoff from the site will be collected in a closed drainage system and discharged to the public storm sewer on Railroad Avenue or Pearson Street. All stormwater runoff will receive at least 80% Total Suspended Solids removal and 70% phosphorus treatment before discharge to the public storm sewer.

2. The stormwater management system has been designed such that proposed peak rates of runoff do not exceed existing rates for all storm events considered.

The proposed development meets this standard. A small infiltration system will be implemented to promote groundwater recharge and mitigate the post development rate of runoff prior to discharging to the Railroad Ave drainage system. Stormwater runoff to Pearson Street will be reduced by reducing the area of land tributary to the street.

3. Loss of annual recharge to groundwater has been eliminated or minimized through the use of environmentally sensitive site design, low impact development techniques, stormwater best management practices, and good operation and maintenance.

The proposed development meets this standard. The site will result in a slight increase in impervious area. Groundwater will be recharged with a subsurface Cultec system to comply with this standard.

4. The proposed stormwater management system has been designed to remove a minimum of 80% of the average annual post-construction load of Total Suspended Solids (TSS).

The proposed development meets this standard. All stormwater runoff from paved areas of the site will pass through a treatment train consisting catch basins, proprietary pretreatment CDS units and a jellyfish phosphorous treatment unit. A portion of the site will also be recharged which provides further treatment of stormwater runoff.

5. Land Uses with Higher Potential Pollutant Load.

This standard does not apply.

6. Discharges to critical areas.

This standard does not apply.

7. Redevelopment Projects: the project consists of a mix of new development and redevelopment.

The project includes a mix of new development and redevelopment. All standards are fully met as described above and no relief is sought under this standard.

8. A Construction Phase Operation and Maintenance Plan is included herewith. A Stormwater Pollution Prevention Plan following the EPA guidelines under the National Pollutant Discharge Elimination System will be prepared prior to construction.

The proposed development meets this standard.

9. A long-term operation and maintenance plan: A long-term O&M has been prepared to provide guidance for current and future owners to inspect and maintain the stormwater management systems in perpetuity. A copy of this O&M plan is included herein.

The proposed development meets this standard.

10. Illicit discharges: To the best of our knowledge and belief there are no illicit discharges to the stormwater management system on this site. A certification is included herein.

The proposed development meets this standard.

V. Conclusion

The Town Yard development project fully complies with the Massachusetts Stormwater Management Handbook and Andover Stormwater & Erosion Control Bylaw.

For questions regarding this Drainage Report, please contact The Morin-Cameron Group, Inc. between the hours of 8:30am to 4:30pm at (978) 373-0310.

FIGURES

APPROXIMATE

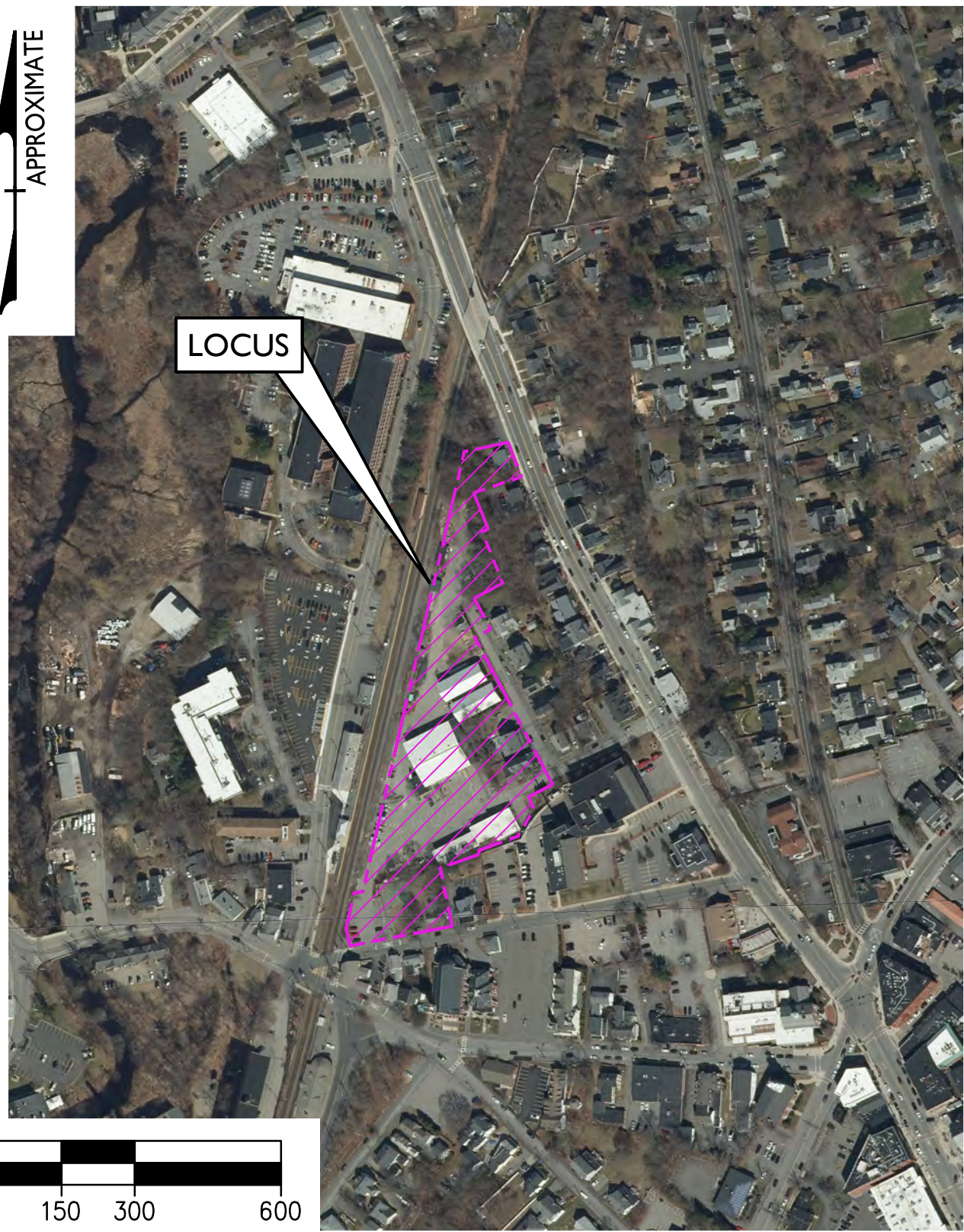

LOCUS



THE MORIN-CAMERON GROUP, INC.

66 ELM STREET, DANVERS, MA 01923

P: 978-777-8586

WWW.MORINCAMERON.COM

ORTHO MAP
"ANDOVER TOWN YARD"
IN
ANDOVER, MA

DATE: NOVEMBER 15, 2023

Scale: 1" = 300'

FIGURE #1

APPROXIMATE

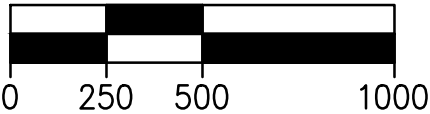
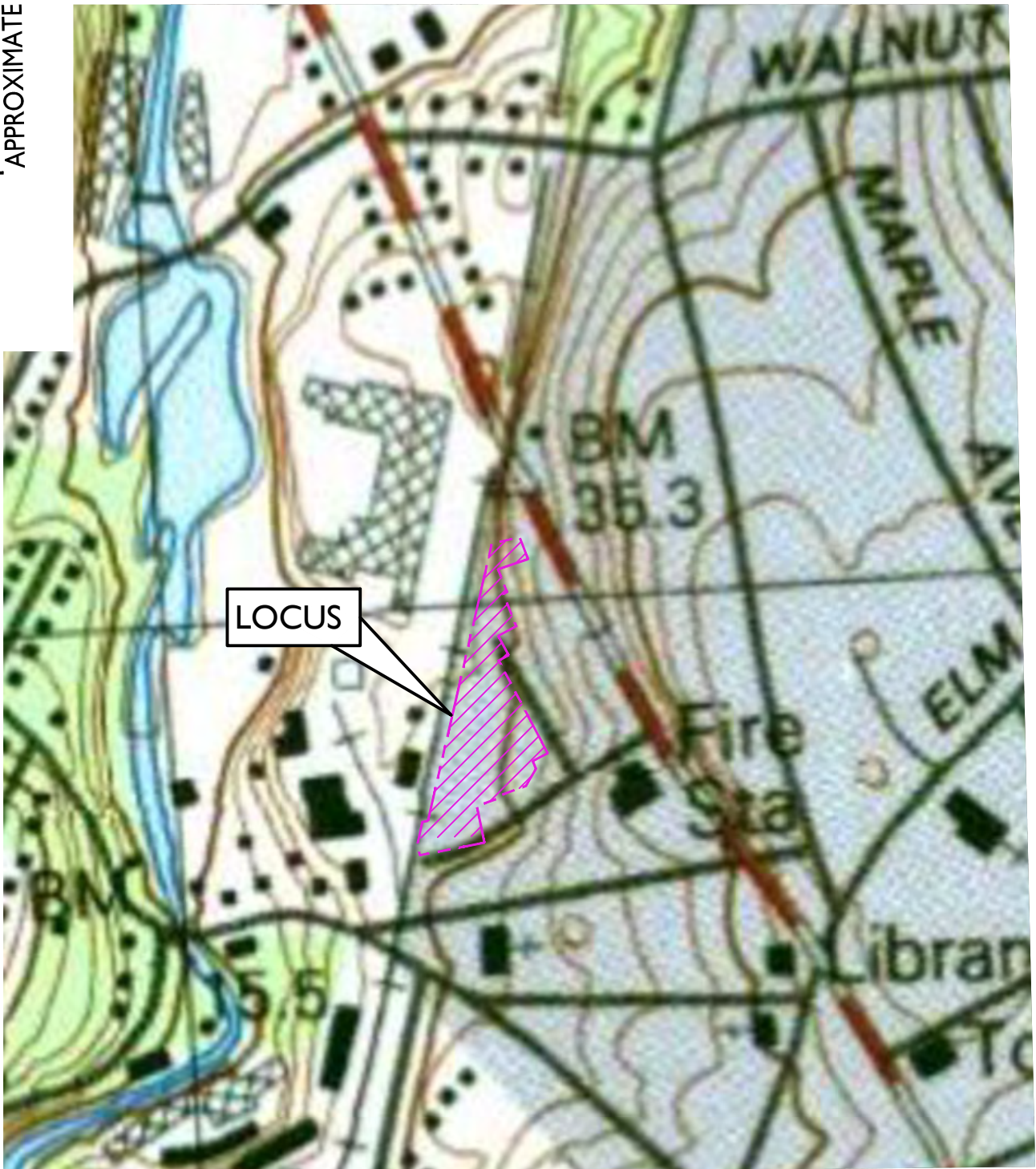

THE MORIN-CAMERON GROUP, INC.

66 ELM STREET, DANVERS, MA 01923

P: 978-777-8586

WWW.MORINCAMERON.COM

USGS MAP
"ANDOVER TOWN YARD" IN
ANDOVER, MA

DATE: NOVEMBER 15, 2023

SCALE: 1" = 500'

FIGURE #2

APPROXIMATE

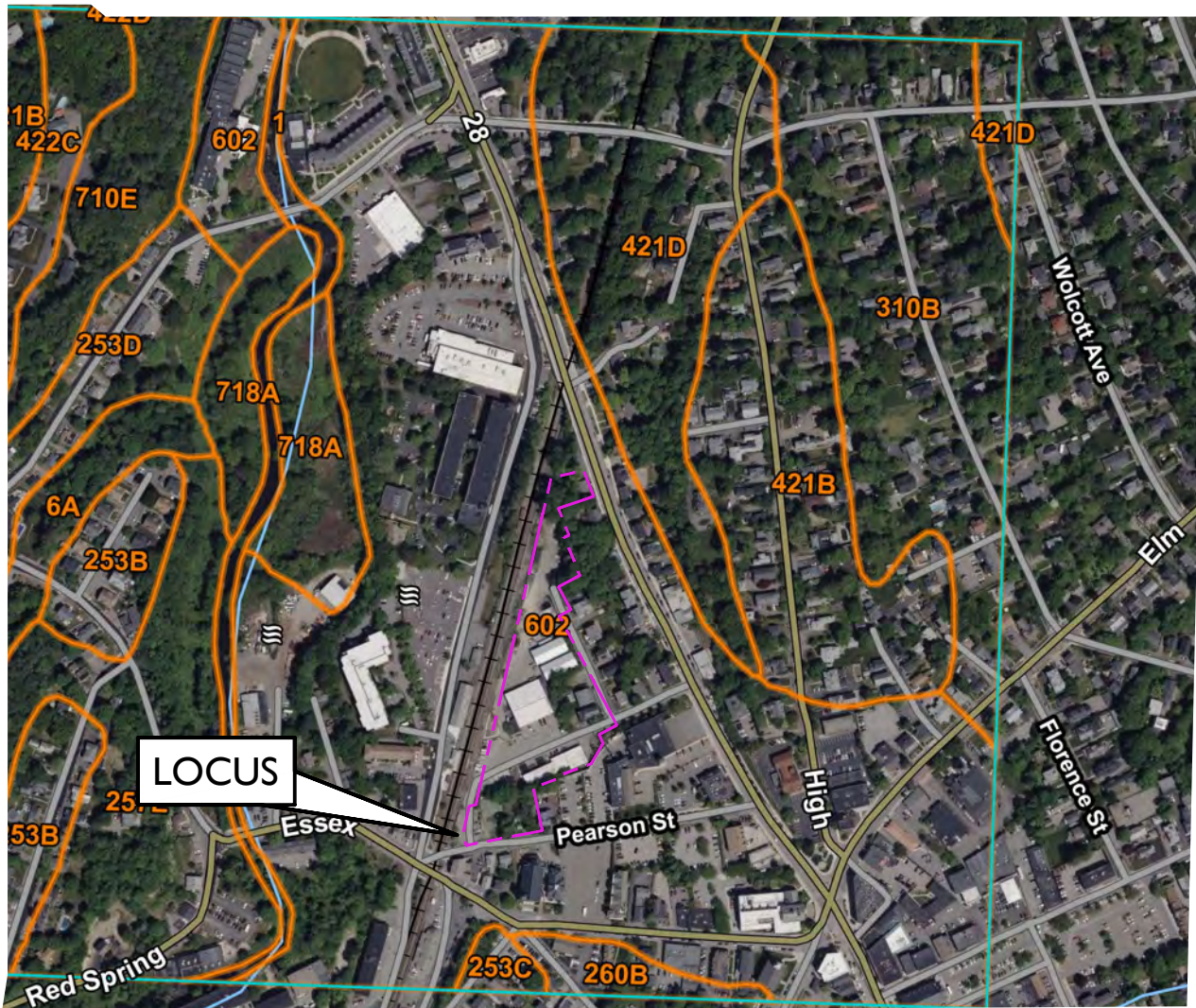

LEGEND:

602 URBAN LAND

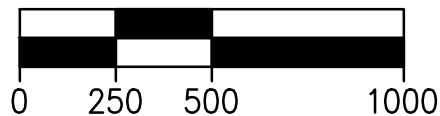

THE MORIN-CAMERON GROUP, INC.

66 ELM STREET, DANVERS, MA 01923

P: 978-777-8586

WWW.MORINCAMERON.COM

SCS SOILS MAP
"ANDOVER TOWN YARD"
ANDOVER, MA

DATE: NOVEMBER 15, 2023

SCALE: 1" = 500'

FIGURE #3

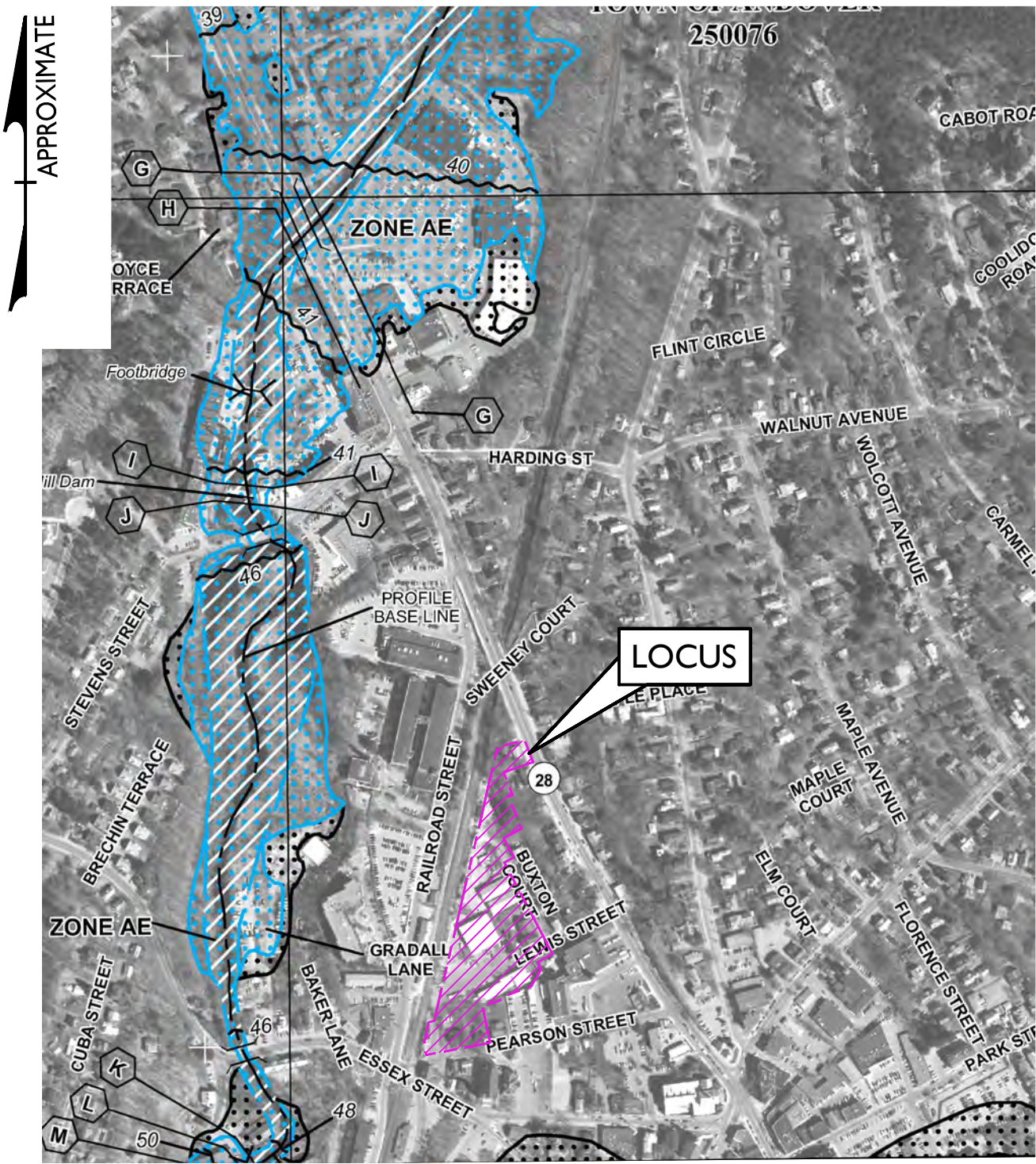

FEMA MAP No: 25009C0217F

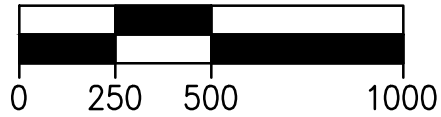

THE MORIN-CAMERON GROUP, INC.
 66 ELM STREET, DANVERS, MA 01923
 P: 978-777-8586
WWW.MORINCAMERON.COM

FEMA MAP
 "ANDOVER TOWN YARD" IN
 ANDOVER, MA

DATE: NOVEMBER 15, 2023

Scale: 1" = 500'

FIGURE #4

**APPENDIX A:
MASSDEP STORMWATER
MANAGEMENT REPORT CHECKLIST**



Checklist for Stormwater Report

A. Introduction

Important: When filling out forms on the computer, use only the tab key to move your cursor - do not use the return key.



A Stormwater Report must be submitted with the Notice of Intent permit application to document compliance with the Stormwater Management Standards. The following checklist is NOT a substitute for the Stormwater Report (which should provide more substantive and detailed information) but is offered here as a tool to help the applicant organize their Stormwater Management documentation for their Report and for the reviewer to assess this information in a consistent format. As noted in the Checklist, the Stormwater Report must contain the engineering computations and supporting information set forth in Volume 3 of the [Massachusetts Stormwater Handbook](#). The Stormwater Report must be prepared and certified by a Registered Professional Engineer (RPE) licensed in the Commonwealth.

The Stormwater Report must include:

- The Stormwater Checklist completed and stamped by a Registered Professional Engineer (see page 2) that certifies that the Stormwater Report contains all required submittals.¹ This Checklist is to be used as the cover for the completed Stormwater Report.
- Applicant/Project Name
- Project Address
- Name of Firm and Registered Professional Engineer that prepared the Report
- Long-Term Pollution Prevention Plan required by Standards 4-6
- Construction Period Pollution Prevention and Erosion and Sedimentation Control Plan required by Standard 8²
- Operation and Maintenance Plan required by Standard 9

In addition to all plans and supporting information, the Stormwater Report must include a brief narrative describing stormwater management practices, including environmentally sensitive site design and LID techniques, along with a diagram depicting runoff through the proposed BMP treatment train. Plans are required to show existing and proposed conditions, identify all wetland resource areas, NRCS soil types, critical areas, Land Uses with Higher Potential Pollutant Loads (LUHPPL), and any areas on the site where infiltration rate is greater than 2.4 inches per hour. The Plans shall identify the drainage areas for both existing and proposed conditions at a scale that enables verification of supporting calculations.

As noted in the Checklist, the Stormwater Management Report shall document compliance with each of the Stormwater Management Standards as provided in the Massachusetts Stormwater Handbook. The soils evaluation and calculations shall be done using the methodologies set forth in Volume 3 of the Massachusetts Stormwater Handbook.

To ensure that the Stormwater Report is complete, applicants are required to fill in the Stormwater Report Checklist by checking the box to indicate that the specified information has been included in the Stormwater Report. If any of the information specified in the checklist has not been submitted, the applicant must provide an explanation. The completed Stormwater Report Checklist and Certification must be submitted with the Stormwater Report.

¹ The Stormwater Report may also include the Illicit Discharge Compliance Statement required by Standard 10. If not included in the Stormwater Report, the Illicit Discharge Compliance Statement must be submitted prior to the discharge of stormwater runoff to the post-construction best management practices.

² For some complex projects, it may not be possible to include the Construction Period Erosion and Sedimentation Control Plan in the Stormwater Report. In that event, the issuing authority has the discretion to issue an Order of Conditions that approves the project and includes a condition requiring the proponent to submit the Construction Period Erosion and Sedimentation Control Plan before commencing any land disturbance activity on the site.



Checklist for Stormwater Report

B. Stormwater Checklist and Certification

The following checklist is intended to serve as a guide for applicants as to the elements that ordinarily need to be addressed in a complete Stormwater Report. The checklist is also intended to provide conservation commissions and other reviewing authorities with a summary of the components necessary for a comprehensive Stormwater Report that addresses the ten Stormwater Standards.

Note: Because stormwater requirements vary from project to project, it is possible that a complete Stormwater Report may not include information on some of the subjects specified in the Checklist. If it is determined that a specific item does not apply to the project under review, please note that the item is not applicable (N.A.) and provide the reasons for that determination.

A complete checklist must include the Certification set forth below signed by the Registered Professional Engineer who prepared the Stormwater Report.

Registered Professional Engineer's Certification

I have reviewed the Stormwater Report, including the soil evaluation, computations, Long-term Pollution Prevention Plan, the Construction Period Erosion and Sedimentation Control Plan (if included), the Long-term Post-Construction Operation and Maintenance Plan, the Illicit Discharge Compliance Statement (if included) and the plans showing the stormwater management system, and have determined that they have been prepared in accordance with the requirements of the Stormwater Management Standards as further elaborated by the Massachusetts Stormwater Handbook. I have also determined that the information presented in the Stormwater Checklist is accurate and that the information presented in the Stormwater Report accurately reflects conditions at the site as of the date of this permit application.

Registered Professional Engineer Block and Signature

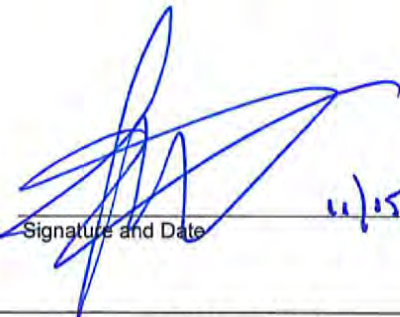

Signature and Date 11/15/23

Checklist

Project Type: Is the application for new development, redevelopment, or a mix of new and redevelopment?

- New development
- Redevelopment
- Mix of New Development and Redevelopment



Checklist for Stormwater Report

Checklist (continued)

LID Measures: Stormwater Standards require LID measures to be considered. Document what environmentally sensitive design and LID Techniques were considered during the planning and design of the project:

- No disturbance to any Wetland Resource Areas
- Site Design Practices (e.g. clustered development, reduced frontage setbacks)
- Reduced Impervious Area (Redevelopment Only)
- Minimizing disturbance to existing trees and shrubs
- LID Site Design Credit Requested:
 - Credit 1
 - Credit 2
 - Credit 3
- Use of "country drainage" versus curb and gutter conveyance and pipe
- Bioretention Cells (includes Rain Gardens)
- Constructed Stormwater Wetlands (includes Gravel Wetlands designs)
- Treebox Filter
- Water Quality Swale
- Grass Channel
- Green Roof
- Other (describe): Phosphorous Treatment

Standard 1: No New Untreated Discharges

- No new untreated discharges
- Outlets have been designed so there is no erosion or scour to wetlands and waters of the Commonwealth
- Supporting calculations specified in Volume 3 of the Massachusetts Stormwater Handbook included.



Checklist for Stormwater Report

Checklist (continued)

Standard 2: Peak Rate Attenuation

- Standard 2 waiver requested because the project is located in land subject to coastal storm flowage and stormwater discharge is to a wetland subject to coastal flooding.
- Evaluation provided to determine whether off-site flooding increases during the 100-year 24-hour storm.
- Calculations provided to show that post-development peak discharge rates do not exceed pre-development rates for the 2-year and 10-year 24-hour storms. If evaluation shows that off-site flooding increases during the 100-year 24-hour storm, calculations are also provided to show that post-development peak discharge rates do not exceed pre-development rates for the 100-year 24-hour storm.

Standard 3: Recharge

- Soil Analysis provided.
- Required Recharge Volume calculation provided.
- Required Recharge volume reduced through use of the LID site Design Credits.
- Sizing the infiltration, BMPs is based on the following method: Check the method used.
 - Static
 - Simple Dynamic
 - Dynamic Field¹
- Runoff from all impervious areas at the site discharging to the infiltration BMP.
- Runoff from all impervious areas at the site is *not* discharging to the infiltration BMP and calculations are provided showing that the drainage area contributing runoff to the infiltration BMPs is sufficient to generate the required recharge volume.
- Recharge BMPs have been sized to infiltrate the Required Recharge Volume.
- Recharge BMPs have been sized to infiltrate the Required Recharge Volume *only* to the maximum extent practicable for the following reason:
 - Site is comprised solely of C and D soils and/or bedrock at the land surface
 - M.G.L. c. 21E sites pursuant to 310 CMR 40.0000
 - Solid Waste Landfill pursuant to 310 CMR 19.000
 - Project is otherwise subject to Stormwater Management Standards only to the maximum extent practicable.
- Calculations showing that the infiltration BMPs will drain in 72 hours are provided.
- Property includes a M.G.L. c. 21E site or a solid waste landfill and a mounding analysis is included.

¹ 80% TSS removal is required prior to discharge to infiltration BMP if Dynamic Field method is used.



Checklist for Stormwater Report

Checklist (continued)

Standard 3: Recharge (continued)

- The infiltration BMP is used to attenuate peak flows during storms greater than or equal to the 10-year 24-hour storm and separation to seasonal high groundwater is less than 4 feet and a mounding analysis is provided.
- Documentation is provided showing that infiltration BMPs do not adversely impact nearby wetland resource areas.

Standard 4: Water Quality

The Long-Term Pollution Prevention Plan typically includes the following:

- Good housekeeping practices;
 - Provisions for storing materials and waste products inside or under cover;
 - Vehicle washing controls;
 - Requirements for routine inspections and maintenance of stormwater BMPs;
 - Spill prevention and response plans;
 - Provisions for maintenance of lawns, gardens, and other landscaped areas;
 - Requirements for storage and use of fertilizers, herbicides, and pesticides;
 - Pet waste management provisions;
 - Provisions for operation and management of septic systems;
 - Provisions for solid waste management;
 - Snow disposal and plowing plans relative to Wetland Resource Areas;
 - Winter Road Salt and/or Sand Use and Storage restrictions;
 - Street sweeping schedules;
 - Provisions for prevention of illicit discharges to the stormwater management system;
 - Documentation that Stormwater BMPs are designed to provide for shutdown and containment in the event of a spill or discharges to or near critical areas or from LUHPPL;
 - Training for staff or personnel involved with implementing Long-Term Pollution Prevention Plan;
 - List of Emergency contacts for implementing Long-Term Pollution Prevention Plan.
- A Long-Term Pollution Prevention Plan is attached to Stormwater Report and is included as an attachment to the Wetlands Notice of Intent.
 - Treatment BMPs subject to the 44% TSS removal pretreatment requirement and the one inch rule for calculating the water quality volume are included, and discharge:
 - is within the Zone II or Interim Wellhead Protection Area
 - is near or to other critical areas
 - is within soils with a rapid infiltration rate (greater than 2.4 inches per hour)
 - involves runoff from land uses with higher potential pollutant loads.
 - The Required Water Quality Volume is reduced through use of the LID site Design Credits.
 - Calculations documenting that the treatment train meets the 80% TSS removal requirement and, if applicable, the 44% TSS removal pretreatment requirement, are provided.



Checklist for Stormwater Report

Checklist (continued)

Standard 4: Water Quality (continued)

- The BMP is sized (and calculations provided) based on:
 - The ½" or 1" Water Quality Volume or
 - The equivalent flow rate associated with the Water Quality Volume and documentation is provided showing that the BMP treats the required water quality volume.
- The applicant proposes to use proprietary BMPs, and documentation supporting use of proprietary BMP and proposed TSS removal rate is provided. This documentation may be in the form of the propriety BMP checklist found in Volume 2, Chapter 4 of the Massachusetts Stormwater Handbook and submitting copies of the TARP Report, STEP Report, and/or other third party studies verifying performance of the proprietary BMPs.
- A TMDL exists that indicates a need to reduce pollutants other than TSS and documentation showing that the BMPs selected are consistent with the TMDL is provided.

Standard 5: Land Uses With Higher Potential Pollutant Loads (LUHPPLs)

- The NPDES Multi-Sector General Permit covers the land use and the Stormwater Pollution Prevention Plan (SWPPP) has been included with the Stormwater Report.
- The NPDES Multi-Sector General Permit covers the land use and the SWPPP will be submitted **prior to** the discharge of stormwater to the post-construction stormwater BMPs.
- The NPDES Multi-Sector General Permit does **not** cover the land use.
- LUHPPLs are located at the site and industry specific source control and pollution prevention measures have been proposed to reduce or eliminate the exposure of LUHPPLs to rain, snow, snow melt and runoff, and been included in the long term Pollution Prevention Plan.
- All exposure has been eliminated.
- All exposure has **not** been eliminated and all BMPs selected are on MassDEP LUHPPL list.
- The LUHPPL has the potential to generate runoff with moderate to higher concentrations of oil and grease (e.g. all parking lots with >1000 vehicle trips per day) and the treatment train includes an oil grit separator, a filtering bioretention area, a sand filter or equivalent.

Standard 6: Critical Areas

- The discharge is near or to a critical area and the treatment train includes only BMPs that MassDEP has approved for stormwater discharges to or near that particular class of critical area.
- Critical areas and BMPs are identified in the Stormwater Report.



Checklist for Stormwater Report

Checklist (continued)

Standard 7: Redevelopments and Other Projects Subject to the Standards only to the maximum extent practicable

- The project is subject to the Stormwater Management Standards only to the maximum Extent Practicable as a:
 - Limited Project
 - Small Residential Projects: 5-9 single family houses or 5-9 units in a multi-family development provided there is no discharge that may potentially affect a critical area.
 - Small Residential Projects: 2-4 single family houses or 2-4 units in a multi-family development with a discharge to a critical area
 - Marina and/or boatyard provided the hull painting, service and maintenance areas are protected from exposure to rain, snow, snow melt and runoff
 - Bike Path and/or Foot Path
 - Redevelopment Project
 - Redevelopment portion of mix of new and redevelopment.
- Certain standards are not fully met (Standard No. 1, 8, 9, and 10 must always be fully met) and an explanation of why these standards are not met is contained in the Stormwater Report.
- The project involves redevelopment and a description of all measures that have been taken to improve existing conditions is provided in the Stormwater Report. The redevelopment checklist found in Volume 2 Chapter 3 of the Massachusetts Stormwater Handbook may be used to document that the proposed stormwater management system (a) complies with Standards 2, 3 and the pretreatment and structural BMP requirements of Standards 4-6 to the maximum extent practicable and (b) improves existing conditions.

Standard 8: Construction Period Pollution Prevention and Erosion and Sedimentation Control

A Construction Period Pollution Prevention and Erosion and Sedimentation Control Plan must include the following information:

- Narrative;
 - Construction Period Operation and Maintenance Plan;
 - Names of Persons or Entity Responsible for Plan Compliance;
 - Construction Period Pollution Prevention Measures;
 - Erosion and Sedimentation Control Plan Drawings;
 - Detail drawings and specifications for erosion control BMPs, including sizing calculations;
 - Vegetation Planning;
 - Site Development Plan;
 - Construction Sequencing Plan;
 - Sequencing of Erosion and Sedimentation Controls;
 - Operation and Maintenance of Erosion and Sedimentation Controls;
 - Inspection Schedule;
 - Maintenance Schedule;
 - Inspection and Maintenance Log Form.
- A Construction Period Pollution Prevention and Erosion and Sedimentation Control Plan containing the information set forth above has been included in the Stormwater Report.



Checklist for Stormwater Report

Checklist (continued)

Standard 8: Construction Period Pollution Prevention and Erosion and Sedimentation Control (continued)

- The project is highly complex and information is included in the Stormwater Report that explains why it is not possible to submit the Construction Period Pollution Prevention and Erosion and Sedimentation Control Plan with the application. A Construction Period Pollution Prevention and Erosion and Sedimentation Control has **not** been included in the Stormwater Report but will be submitted **before** land disturbance begins.
- The project is **not** covered by a NPDES Construction General Permit.
- The project is covered by a NPDES Construction General Permit and a copy of the SWPPP is in the Stormwater Report.
- The project is covered by a NPDES Construction General Permit but no SWPPP been submitted. The SWPPP will be submitted BEFORE land disturbance begins.

Standard 9: Operation and Maintenance Plan

- The Post Construction Operation and Maintenance Plan is included in the Stormwater Report and includes the following information:
 - Name of the stormwater management system owners;
 - Party responsible for operation and maintenance;
 - Schedule for implementation of routine and non-routine maintenance tasks;
 - Plan showing the location of all stormwater BMPs maintenance access areas;
 - Description and delineation of public safety features;
 - Estimated operation and maintenance budget; and
 - Operation and Maintenance Log Form.
- The responsible party is **not** the owner of the parcel where the BMP is located and the Stormwater Report includes the following submissions:
 - A copy of the legal instrument (deed, homeowner's association, utility trust or other legal entity) that establishes the terms of and legal responsibility for the operation and maintenance of the project site stormwater BMPs;
 - A plan and easement deed that allows site access for the legal entity to operate and maintain BMP functions.

Standard 10: Prohibition of Illicit Discharges

- The Long-Term Pollution Prevention Plan includes measures to prevent illicit discharges;
- An Illicit Discharge Compliance Statement is attached;
- NO Illicit Discharge Compliance Statement is attached but will be submitted **prior to** the discharge of any stormwater to post-construction BMPs.

**APPENDIX B:
EXISTING CONDITIONS
HYDROLOGIC ANALYSIS**

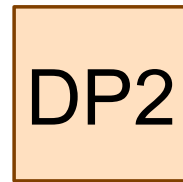
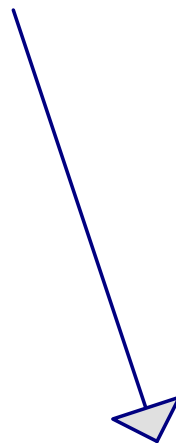

Public Drainage System

Catch Basin, Pearson St

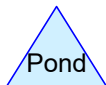
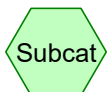

4145 Existing

Prepared by The Morin-Cameron Group, Inc
HydroCAD® 10.20-3g s/n 00401 © 2023 HydroCAD Software Solutions LLC

Printed 11/14/2023

Page 2

Rainfall Events Listing

Event#	Event Name	Storm Type	Curve	Mode	Duration (hours)	B/B	Depth (inches)	AMC
1	2-yr	NOAA 24-hr	D	Default	24.00	1	3.16	2
2	10-yr	NOAA 24-hr	D	Default	24.00	1	5.01	2
3	25-yr	NOAA 24-hr	D	Default	24.00	1	6.16	2
4	100-yr	NOAA 24-hr	D	Default	24.00	1	7.94	2

4145 Existing

Prepared by The Morin-Cameron Group, Inc
HydroCAD® 10.20-3g s/n 00401 © 2023 HydroCAD Software Solutions LLC

Printed 11/14/2023

Page 3

Area Listing (all nodes)

Area (sq-ft)	CN	Description (subcatchment-numbers)
91,247	85	1/8 acre lots, 65% imp, HSG B (ES1)
26,315	85	Gravel surface, HSG B "100% imp" (ES1)
26,935	61	Open space (50-75% Grass Cover), HSG B (ES1, ES2)
122,150	98	Paved parking, HSG B (ES1, ES2)
35,033	98	Roofs, HSG B (ES1, ES2)
12,116	55	Woods, HSG B (ES1)

4145 Existing

Prepared by The Morin-Cameron Group, Inc
HydroCAD® 10.20-3g s/n 00401 © 2023 HydroCAD Software Solutions LLC

Printed 11/14/2023

Page 4

Soil Listing (all nodes)

Area (sq-ft)	Soil Group	Subcatchment Numbers
0	HSG A	
313,796	HSG B	ES1, ES2
0	HSG C	
0	HSG D	
0	Other	

4145 Existing

Prepared by The Morin-Cameron Group, Inc

HydroCAD® 10.20-3g s/n 00401 © 2023 HydroCAD Software Solutions LLC

NOAA 24-hr D 2-yr Rainfall=3.16"

Printed 11/14/2023

Page 5

Time span=0.00-36.00 hrs, dt=0.01 hrs, 3601 points
Runoff by SCS TR-20 method, UH=SCS, Weighted-CN
Reach routing by Dyn-Stor-Ind method - Pond routing by Dyn-Stor-Ind method

Subcatchment ES1:

Runoff Area=300,300 sf 78.05% Impervious Runoff Depth=1.96"
Flow Length=592' Tc=6.0 min CN=88 Runoff=15.7 cfs 49,076 cf

Subcatchment ES2:

Runoff Area=13,496 sf 62.41% Impervious Runoff Depth=1.65"
Flow Length=251' Tc=6.0 min CN=84 Runoff=0.6 cfs 1,854 cf

Reach DP1: Public Drainage System

Inflow=15.7 cfs 49,076 cf
Outflow=15.7 cfs 49,076 cf

Reach DP2: Catch Basin, Pearson St

Inflow=0.6 cfs 1,854 cf
Outflow=0.6 cfs 1,854 cf

4145 Existing

Prepared by The Morin-Cameron Group, Inc

HydroCAD® 10.20-3g s/n 00401 © 2023 HydroCAD Software Solutions LLC

NOAA 24-hr D 2-yr Rainfall=3.16"

Printed 11/14/2023

Page 6

Summary for Subcatchment ES1:

Runoff = 15.7 cfs @ 12.13 hrs, Volume= 49,076 cf, Depth= 1.96"
 Routed to Reach DP1 : Public Drainage System

Runoff by SCS TR-20 method, UH=SCS, Weighted-CN, Time Span= 0.00-36.00 hrs, dt= 0.01 hrs
 NOAA 24-hr D 2-yr Rainfall=3.16"

Area (sf)	CN	Description
114,973	98	Paved parking, HSG B
33,787	98	Roofs, HSG B
* 12,116	55	Woods, HSG B
* 21,862	61	Open space (50-75% Grass Cover), HSG B
* 26,315	85	Gravel surface, HSG B "100% imp"
91,247	85	1/8 acre lots, 65% imp, HSG B
300,300	88	Weighted Average
65,914		21.95% Pervious Area
234,386		78.05% Impervious Area

Tc (min)	Length (feet)	Slope (ft/ft)	Velocity (ft/sec)	Capacity (cfs)	Description
0.4	50	0.0900	2.17		Sheet Flow, Sheet Flow Smooth surfaces n= 0.011 P2= 3.15"
0.3	138	0.2029	9.14		Shallow Concentrated Flow, Shallow Concentrated Paved Kv= 20.3 fps
0.4	128	0.0800	5.74		Shallow Concentrated Flow, Shallow Concentrated Paved Kv= 20.3 fps
0.1	111	0.1050	15.92	12.51	Pipe Channel, RCP_Round 12" 12.0" Round Area= 0.8 sf Perim= 3.1' r= 0.25' n= 0.012 Concrete pipe, finished
0.1	87	0.1400	18.39	14.44	Pipe Channel, RCP_Round 12" 12.0" Round Area= 0.8 sf Perim= 3.1' r= 0.25' n= 0.012 Concrete pipe, finished
0.3	78	0.0100	4.91	3.86	Pipe Channel, RCP_Round 12" 12.0" Round Area= 0.8 sf Perim= 3.1' r= 0.25' n= 0.012 Concrete pipe, finished
4.4					Direct Entry, Adjustment to 0.1hr
6.0	592	Total			

Summary for Subcatchment ES2:

Runoff = 0.6 cfs @ 12.13 hrs, Volume= 1,854 cf, Depth= 1.65"
 Routed to Reach DP2 : Catch Basin, Pearson St

Runoff by SCS TR-20 method, UH=SCS, Weighted-CN, Time Span= 0.00-36.00 hrs, dt= 0.01 hrs
 NOAA 24-hr D 2-yr Rainfall=3.16"

4145 Existing

NOAA 24-hr D 2-yr Rainfall=3.16"

Prepared by The Morin-Cameron Group, Inc

Printed 11/14/2023

HydroCAD® 10.20-3g s/n 00401 © 2023 HydroCAD Software Solutions LLC

Page 7

Area (sf)	CN	Description
7,177	98	Paved parking, HSG B
1,246	98	Roofs, HSG B
* 5,073	61	Open space (50-75% Grass Cover), HSG B
13,496	84	Weighted Average
5,073		37.59% Pervious Area
8,423		62.41% Impervious Area

Tc (min)	Length (feet)	Slope (ft/ft)	Velocity (ft/sec)	Capacity (cfs)	Description
0.5	50	0.0500	1.71		Sheet Flow, Sheet Flow Smooth surfaces n= 0.011 P2= 3.15"
0.4	121	0.0500	4.54		Shallow Concentrated Flow, Shallow Concentrated Paved Kv= 20.3 fps
0.1	80	0.0400	9.83	7.72	Pipe Channel, RCP_Round 12" 12.0" Round Area= 0.8 sf Perim= 3.1' r= 0.25' n= 0.012 Concrete pipe, finished
5.0					Direct Entry, Adjustment to 0.1hr
6.0	251	Total			

Summary for Reach DP1: Public Drainage System

Inflow Area = 300,300 sf, 78.05% Impervious, Inflow Depth = 1.96" for 2-yr event
 Inflow = 15.7 cfs @ 12.13 hrs, Volume= 49,076 cf
 Outflow = 15.7 cfs @ 12.13 hrs, Volume= 49,076 cf, Atten= 0%, Lag= 0.0 min

Routing by Dyn-Stor-Ind method, Time Span= 0.00-36.00 hrs, dt= 0.01 hrs

Summary for Reach DP2: Catch Basin, Pearson St

Inflow Area = 13,496 sf, 62.41% Impervious, Inflow Depth = 1.65" for 2-yr event
 Inflow = 0.6 cfs @ 12.13 hrs, Volume= 1,854 cf
 Outflow = 0.6 cfs @ 12.13 hrs, Volume= 1,854 cf, Atten= 0%, Lag= 0.0 min

Routing by Dyn-Stor-Ind method, Time Span= 0.00-36.00 hrs, dt= 0.01 hrs

4145 Existing

NOAA 24-hr D 10-yr Rainfall=5.01"

Prepared by The Morin-Cameron Group, Inc

Printed 11/14/2023

HydroCAD® 10.20-3g s/n 00401 © 2023 HydroCAD Software Solutions LLC

Page 8

Time span=0.00-36.00 hrs, dt=0.01 hrs, 3601 points
Runoff by SCS TR-20 method, UH=SCS, Weighted-CN
Reach routing by Dyn-Stor-Ind method - Pond routing by Dyn-Stor-Ind method

Subcatchment ES1: Runoff Area=300,300 sf 78.05% Impervious Runoff Depth=3.68"
Flow Length=592' Tc=6.0 min CN=88 Runoff=28.7 cfs 92,053 cf

Subcatchment ES2: Runoff Area=13,496 sf 62.41% Impervious Runoff Depth=3.28"
Flow Length=251' Tc=6.0 min CN=84 Runoff=1.2 cfs 3,688 cf

Reach DP1: Public Drainage System Inflow=28.7 cfs 92,053 cf
Outflow=28.7 cfs 92,053 cf

Reach DP2: Catch Basin, Pearson St Inflow=1.2 cfs 3,688 cf
Outflow=1.2 cfs 3,688 cf

4145 Existing

NOAA 24-hr D 10-yr Rainfall=5.01"

Prepared by The Morin-Cameron Group, Inc

Printed 11/14/2023

HydroCAD® 10.20-3g s/n 00401 © 2023 HydroCAD Software Solutions LLC

Page 9

Summary for Subcatchment ES1:

Runoff = 28.7 cfs @ 12.13 hrs, Volume= 92,053 cf, Depth= 3.68"
 Routed to Reach DP1 : Public Drainage System

Runoff by SCS TR-20 method, UH=SCS, Weighted-CN, Time Span= 0.00-36.00 hrs, dt= 0.01 hrs
 NOAA 24-hr D 10-yr Rainfall=5.01"

Area (sf)	CN	Description
114,973	98	Paved parking, HSG B
33,787	98	Roofs, HSG B
* 12,116	55	Woods, HSG B
* 21,862	61	Open space (50-75% Grass Cover), HSG B
* 26,315	85	Gravel surface, HSG B "100% imp"
91,247	85	1/8 acre lots, 65% imp, HSG B
300,300	88	Weighted Average
65,914		21.95% Pervious Area
234,386		78.05% Impervious Area

Tc (min)	Length (feet)	Slope (ft/ft)	Velocity (ft/sec)	Capacity (cfs)	Description
0.4	50	0.0900	2.17		Sheet Flow, Sheet Flow Smooth surfaces n= 0.011 P2= 3.15"
0.3	138	0.2029	9.14		Shallow Concentrated Flow, Shallow Concentrated Paved Kv= 20.3 fps
0.4	128	0.0800	5.74		Shallow Concentrated Flow, Shallow Concentrated Paved Kv= 20.3 fps
0.1	111	0.1050	15.92	12.51	Pipe Channel, RCP_Round 12" 12.0" Round Area= 0.8 sf Perim= 3.1' r= 0.25' n= 0.012 Concrete pipe, finished
0.1	87	0.1400	18.39	14.44	Pipe Channel, RCP_Round 12" 12.0" Round Area= 0.8 sf Perim= 3.1' r= 0.25' n= 0.012 Concrete pipe, finished
0.3	78	0.0100	4.91	3.86	Pipe Channel, RCP_Round 12" 12.0" Round Area= 0.8 sf Perim= 3.1' r= 0.25' n= 0.012 Concrete pipe, finished
4.4					Direct Entry, Adjustment to 0.1hr
6.0	592	Total			

Summary for Subcatchment ES2:

Runoff = 1.2 cfs @ 12.13 hrs, Volume= 3,688 cf, Depth= 3.28"
 Routed to Reach DP2 : Catch Basin, Pearson St

Runoff by SCS TR-20 method, UH=SCS, Weighted-CN, Time Span= 0.00-36.00 hrs, dt= 0.01 hrs
 NOAA 24-hr D 10-yr Rainfall=5.01"

4145 Existing

NOAA 24-hr D 10-yr Rainfall=5.01"

Prepared by The Morin-Cameron Group, Inc

Printed 11/14/2023

HydroCAD® 10.20-3g s/n 00401 © 2023 HydroCAD Software Solutions LLC

Page 10

Area (sf)	CN	Description
7,177	98	Paved parking, HSG B
1,246	98	Roofs, HSG B
* 5,073	61	Open space (50-75% Grass Cover), HSG B
13,496	84	Weighted Average
5,073		37.59% Pervious Area
8,423		62.41% Impervious Area

Tc (min)	Length (feet)	Slope (ft/ft)	Velocity (ft/sec)	Capacity (cfs)	Description
0.5	50	0.0500	1.71		Sheet Flow, Sheet Flow Smooth surfaces n= 0.011 P2= 3.15"
0.4	121	0.0500	4.54		Shallow Concentrated Flow, Shallow Concentrated Paved Kv= 20.3 fps
0.1	80	0.0400	9.83	7.72	Pipe Channel, RCP_Round 12" 12.0" Round Area= 0.8 sf Perim= 3.1' r= 0.25' n= 0.012 Concrete pipe, finished
5.0					Direct Entry, Adjustment to 0.1hr
6.0	251	Total			

Summary for Reach DP1: Public Drainage System

Inflow Area = 300,300 sf, 78.05% Impervious, Inflow Depth = 3.68" for 10-yr event
 Inflow = 28.7 cfs @ 12.13 hrs, Volume= 92,053 cf
 Outflow = 28.7 cfs @ 12.13 hrs, Volume= 92,053 cf, Atten= 0%, Lag= 0.0 min

Routing by Dyn-Stor-Ind method, Time Span= 0.00-36.00 hrs, dt= 0.01 hrs

Summary for Reach DP2: Catch Basin, Pearson St

Inflow Area = 13,496 sf, 62.41% Impervious, Inflow Depth = 3.28" for 10-yr event
 Inflow = 1.2 cfs @ 12.13 hrs, Volume= 3,688 cf
 Outflow = 1.2 cfs @ 12.13 hrs, Volume= 3,688 cf, Atten= 0%, Lag= 0.0 min

Routing by Dyn-Stor-Ind method, Time Span= 0.00-36.00 hrs, dt= 0.01 hrs

4145 Existing

Prepared by The Morin-Cameron Group, Inc

HydroCAD® 10.20-3g s/n 00401 © 2023 HydroCAD Software Solutions LLC

NOAA 24-hr D 25-yr Rainfall=6.16"

Printed 11/14/2023

Page 11

Time span=0.00-36.00 hrs, dt=0.01 hrs, 3601 points
Runoff by SCS TR-20 method, UH=SCS, Weighted-CN
Reach routing by Dyn-Stor-Ind method - Pond routing by Dyn-Stor-Ind method

Subcatchment ES1:

Runoff Area=300,300 sf 78.05% Impervious Runoff Depth=4.78"
Flow Length=592' Tc=6.0 min CN=88 Runoff=36.7 cfs 119,622 cf

Subcatchment ES2:

Runoff Area=13,496 sf 62.41% Impervious Runoff Depth=4.35"
Flow Length=251' Tc=6.0 min CN=84 Runoff=1.5 cfs 4,888 cf

Reach DP1: Public Drainage System

Inflow=36.7 cfs 119,622 cf
Outflow=36.7 cfs 119,622 cf

Reach DP2: Catch Basin, Pearson St

Inflow=1.5 cfs 4,888 cf
Outflow=1.5 cfs 4,888 cf

4145 Existing

Prepared by The Morin-Cameron Group, Inc

HydroCAD® 10.20-3g s/n 00401 © 2023 HydroCAD Software Solutions LLC

NOAA 24-hr D 25-yr Rainfall=6.16"

Printed 11/14/2023

Page 12

Summary for Subcatchment ES1:

Runoff = 36.7 cfs @ 12.13 hrs, Volume= 119,622 cf, Depth= 4.78"
 Routed to Reach DP1 : Public Drainage System

Runoff by SCS TR-20 method, UH=SCS, Weighted-CN, Time Span= 0.00-36.00 hrs, dt= 0.01 hrs
 NOAA 24-hr D 25-yr Rainfall=6.16"

Area (sf)	CN	Description
114,973	98	Paved parking, HSG B
33,787	98	Roofs, HSG B
* 12,116	55	Woods, HSG B
* 21,862	61	Open space (50-75% Grass Cover), HSG B
* 26,315	85	Gravel surface, HSG B "100% imp"
91,247	85	1/8 acre lots, 65% imp, HSG B
300,300	88	Weighted Average
65,914		21.95% Pervious Area
234,386		78.05% Impervious Area

Tc (min)	Length (feet)	Slope (ft/ft)	Velocity (ft/sec)	Capacity (cfs)	Description
0.4	50	0.0900	2.17		Sheet Flow, Sheet Flow Smooth surfaces n= 0.011 P2= 3.15"
0.3	138	0.2029	9.14		Shallow Concentrated Flow, Shallow Concentrated Paved Kv= 20.3 fps
0.4	128	0.0800	5.74		Shallow Concentrated Flow, Shallow Concentrated Paved Kv= 20.3 fps
0.1	111	0.1050	15.92	12.51	Pipe Channel, RCP_Round 12" 12.0" Round Area= 0.8 sf Perim= 3.1' r= 0.25' n= 0.012 Concrete pipe, finished
0.1	87	0.1400	18.39	14.44	Pipe Channel, RCP_Round 12" 12.0" Round Area= 0.8 sf Perim= 3.1' r= 0.25' n= 0.012 Concrete pipe, finished
0.3	78	0.0100	4.91	3.86	Pipe Channel, RCP_Round 12" 12.0" Round Area= 0.8 sf Perim= 3.1' r= 0.25' n= 0.012 Concrete pipe, finished
4.4					Direct Entry, Adjustment to 0.1hr
6.0	592	Total			

Summary for Subcatchment ES2:

Runoff = 1.5 cfs @ 12.13 hrs, Volume= 4,888 cf, Depth= 4.35"
 Routed to Reach DP2 : Catch Basin, Pearson St

Runoff by SCS TR-20 method, UH=SCS, Weighted-CN, Time Span= 0.00-36.00 hrs, dt= 0.01 hrs
 NOAA 24-hr D 25-yr Rainfall=6.16"

4145 Existing

NOAA 24-hr D 25-yr Rainfall=6.16"

Prepared by The Morin-Cameron Group, Inc

Printed 11/14/2023

HydroCAD® 10.20-3g s/n 00401 © 2023 HydroCAD Software Solutions LLC

Page 13

Area (sf)	CN	Description
7,177	98	Paved parking, HSG B
1,246	98	Roofs, HSG B
* 5,073	61	Open space (50-75% Grass Cover), HSG B
13,496	84	Weighted Average
5,073		37.59% Pervious Area
8,423		62.41% Impervious Area

Tc (min)	Length (feet)	Slope (ft/ft)	Velocity (ft/sec)	Capacity (cfs)	Description
0.5	50	0.0500	1.71		Sheet Flow, Sheet Flow Smooth surfaces n= 0.011 P2= 3.15"
0.4	121	0.0500	4.54		Shallow Concentrated Flow, Shallow Concentrated Paved Kv= 20.3 fps
0.1	80	0.0400	9.83	7.72	Pipe Channel, RCP_Round 12" 12.0" Round Area= 0.8 sf Perim= 3.1' r= 0.25' n= 0.012 Concrete pipe, finished
5.0					Direct Entry, Adjustment to 0.1hr
6.0	251	Total			

Summary for Reach DP1: Public Drainage System

Inflow Area = 300,300 sf, 78.05% Impervious, Inflow Depth = 4.78" for 25-yr event
 Inflow = 36.7 cfs @ 12.13 hrs, Volume= 119,622 cf
 Outflow = 36.7 cfs @ 12.13 hrs, Volume= 119,622 cf, Atten= 0%, Lag= 0.0 min

Routing by Dyn-Stor-Ind method, Time Span= 0.00-36.00 hrs, dt= 0.01 hrs

Summary for Reach DP2: Catch Basin, Pearson St

Inflow Area = 13,496 sf, 62.41% Impervious, Inflow Depth = 4.35" for 25-yr event
 Inflow = 1.5 cfs @ 12.13 hrs, Volume= 4,888 cf
 Outflow = 1.5 cfs @ 12.13 hrs, Volume= 4,888 cf, Atten= 0%, Lag= 0.0 min

Routing by Dyn-Stor-Ind method, Time Span= 0.00-36.00 hrs, dt= 0.01 hrs

4145 Existing

Prepared by The Morin-Cameron Group, Inc

HydroCAD® 10.20-3g s/n 00401 © 2023 HydroCAD Software Solutions LLC

NOAA 24-hr D 100-yr Rainfall=7.94"

Printed 11/14/2023

Page 14

Time span=0.00-36.00 hrs, dt=0.01 hrs, 3601 points
Runoff by SCS TR-20 method, UH=SCS, Weighted-CN
Reach routing by Dyn-Stor-Ind method - Pond routing by Dyn-Stor-Ind method

Subcatchment ES1:

Runoff Area=300,300 sf 78.05% Impervious Runoff Depth=6.51"
Flow Length=592' Tc=6.0 min CN=88 Runoff=49.0 cfs 162,901 cf

Subcatchment ES2:

Runoff Area=13,496 sf 62.41% Impervious Runoff Depth=6.04"
Flow Length=251' Tc=6.0 min CN=84 Runoff=2.1 cfs 6,790 cf

Reach DP1: Public Drainage System

Inflow=49.0 cfs 162,901 cf
Outflow=49.0 cfs 162,901 cf

Reach DP2: Catch Basin, Pearson St

Inflow=2.1 cfs 6,790 cf
Outflow=2.1 cfs 6,790 cf

4145 Existing

Prepared by The Morin-Cameron Group, Inc

HydroCAD® 10.20-3g s/n 00401 © 2023 HydroCAD Software Solutions LLC

NOAA 24-hr D 100-yr Rainfall=7.94"

Printed 11/14/2023

Page 15

Summary for Subcatchment ES1:

Runoff = 49.0 cfs @ 12.13 hrs, Volume= 162,901 cf, Depth= 6.51"
 Routed to Reach DP1 : Public Drainage System

Runoff by SCS TR-20 method, UH=SCS, Weighted-CN, Time Span= 0.00-36.00 hrs, dt= 0.01 hrs
 NOAA 24-hr D 100-yr Rainfall=7.94"

Area (sf)	CN	Description
114,973	98	Paved parking, HSG B
33,787	98	Roofs, HSG B
* 12,116	55	Woods, HSG B
* 21,862	61	Open space (50-75% Grass Cover), HSG B
* 26,315	85	Gravel surface, HSG B "100% imp"
91,247	85	1/8 acre lots, 65% imp, HSG B
300,300	88	Weighted Average
65,914		21.95% Pervious Area
234,386		78.05% Impervious Area

Tc (min)	Length (feet)	Slope (ft/ft)	Velocity (ft/sec)	Capacity (cfs)	Description
0.4	50	0.0900	2.17		Sheet Flow, Sheet Flow Smooth surfaces n= 0.011 P2= 3.15"
0.3	138	0.2029	9.14		Shallow Concentrated Flow, Shallow Concentrated Paved Kv= 20.3 fps
0.4	128	0.0800	5.74		Shallow Concentrated Flow, Shallow Concentrated Paved Kv= 20.3 fps
0.1	111	0.1050	15.92	12.51	Pipe Channel, RCP_Round 12" 12.0" Round Area= 0.8 sf Perim= 3.1' r= 0.25' n= 0.012 Concrete pipe, finished
0.1	87	0.1400	18.39	14.44	Pipe Channel, RCP_Round 12" 12.0" Round Area= 0.8 sf Perim= 3.1' r= 0.25' n= 0.012 Concrete pipe, finished
0.3	78	0.0100	4.91	3.86	Pipe Channel, RCP_Round 12" 12.0" Round Area= 0.8 sf Perim= 3.1' r= 0.25' n= 0.012 Concrete pipe, finished
4.4					Direct Entry, Adjustment to 0.1hr
6.0	592	Total			

Summary for Subcatchment ES2:

Runoff = 2.1 cfs @ 12.13 hrs, Volume= 6,790 cf, Depth= 6.04"
 Routed to Reach DP2 : Catch Basin, Pearson St

Runoff by SCS TR-20 method, UH=SCS, Weighted-CN, Time Span= 0.00-36.00 hrs, dt= 0.01 hrs
 NOAA 24-hr D 100-yr Rainfall=7.94"

4145 Existing

NOAA 24-hr D 100-yr Rainfall=7.94"

Prepared by The Morin-Cameron Group, Inc

Printed 11/14/2023

HydroCAD® 10.20-3g s/n 00401 © 2023 HydroCAD Software Solutions LLC

Page 16

Area (sf)	CN	Description
7,177	98	Paved parking, HSG B
1,246	98	Roofs, HSG B
* 5,073	61	Open space (50-75% Grass Cover), HSG B
13,496	84	Weighted Average
5,073		37.59% Pervious Area
8,423		62.41% Impervious Area

Tc (min)	Length (feet)	Slope (ft/ft)	Velocity (ft/sec)	Capacity (cfs)	Description
0.5	50	0.0500	1.71		Sheet Flow, Sheet Flow Smooth surfaces n= 0.011 P2= 3.15"
0.4	121	0.0500	4.54		Shallow Concentrated Flow, Shallow Concentrated Paved Kv= 20.3 fps
0.1	80	0.0400	9.83	7.72	Pipe Channel, RCP_Round 12" 12.0" Round Area= 0.8 sf Perim= 3.1' r= 0.25' n= 0.012 Concrete pipe, finished
5.0					Direct Entry, Adjustment to 0.1hr
6.0	251	Total			

Summary for Reach DP1: Public Drainage System

Inflow Area = 300,300 sf, 78.05% Impervious, Inflow Depth = 6.51" for 100-yr event
 Inflow = 49.0 cfs @ 12.13 hrs, Volume= 162,901 cf
 Outflow = 49.0 cfs @ 12.13 hrs, Volume= 162,901 cf, Atten= 0%, Lag= 0.0 min

Routing by Dyn-Stor-Ind method, Time Span= 0.00-36.00 hrs, dt= 0.01 hrs

Summary for Reach DP2: Catch Basin, Pearson St

Inflow Area = 13,496 sf, 62.41% Impervious, Inflow Depth = 6.04" for 100-yr event
 Inflow = 2.1 cfs @ 12.13 hrs, Volume= 6,790 cf
 Outflow = 2.1 cfs @ 12.13 hrs, Volume= 6,790 cf, Atten= 0%, Lag= 0.0 min

Routing by Dyn-Stor-Ind method, Time Span= 0.00-36.00 hrs, dt= 0.01 hrs

**APPENDIX C:
PROPOSED CONDITIONS
HYDROLOGIC ANALYSIS**

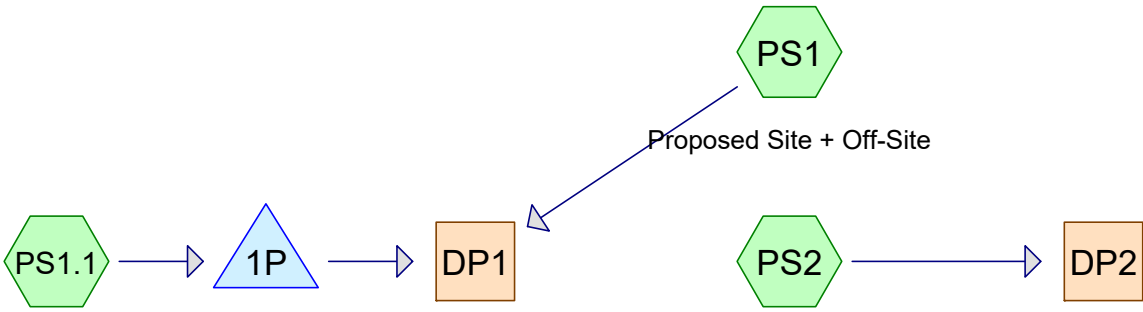

Northern Parking + Dog
Park + Off Site (1/8
acre residential lots)

Public Drainage System

Site Frontage by
Pearson Street

Catch Basin, Pearson St

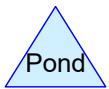
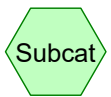

Routing Diagram for 4145 Proposed
 Prepared by The Morin-Cameron Group, Inc, Printed 2/20/2024
 HydroCAD® 10.20-4a s/n 00401 © 2023 HydroCAD Software Solutions LLC

4145 Proposed

Prepared by The Morin-Cameron Group, Inc
HydroCAD® 10.20-4a s/n 00401 © 2023 HydroCAD Software Solutions LLC

Printed 2/20/2024

Page 2

Rainfall Events Listing

Event#	Event Name	Storm Type	Curve	Mode	Duration (hours)	B/B	Depth (inches)	AMC
1	2-yr	NOAA 24-hr	D	Default	24.00	1	3.16	2
2	10-yr	NOAA 24-hr	D	Default	24.00	1	5.01	2
3	25-yr	NOAA 24-hr	D	Default	24.00	1	6.16	2
4	100-yr	NOAA 24-hr	D	Default	24.00	1	7.94	2

4145 Proposed

Prepared by The Morin-Cameron Group, Inc
HydroCAD® 10.20-4a s/n 00401 © 2023 HydroCAD Software Solutions LLC

Printed 2/20/2024

Page 3

Area Listing (all nodes)

Area (sq-ft)	CN	Description (subcatchment-numbers)
91,247	85	1/8 acre lots, 65% imp, HSG B (PS1, PS1.1)
14,391	85	Gravel surface, HSG B "100% imp" (PS1, PS2)
40,739	79	Open Space (75-100% grass cover), HSG B (PS1, PS1.1, PS2)
88,596	98	Paved parking, HSG B (PS1, PS1.1, PS2)
73,101	98	Roofs, HSG B (PS1)
5,722	55	Woods (PS1)
313,796	90	TOTAL AREA

4145 Proposed

NOAA 24-hr D 2-yr Rainfall=3.16"

Prepared by The Morin-Cameron Group, Inc

Printed 2/20/2024

HydroCAD® 10.20-4a s/n 00401 © 2023 HydroCAD Software Solutions LLC

Page 4

Time span=0.00-36.00 hrs, dt=0.01 hrs, 3601 points
 Runoff by SCS TR-20 method, UH=SCS, Weighted-CN
 Reach routing by Dyn-Stor-Ind method - Pond routing by Dyn-Stor-Ind method

Subcatchment PS1: Proposed Site + Runoff Area=245,672 sf 76.55% Impervious Runoff Depth=2.22"
 Tc=6.0 min CN=91 Runoff=14.3 cfs 45,465 cf

Subcatchment PS1.1: Northern Parking + Runoff Area=58,367 sf 65.93% Impervious Runoff Depth=1.96"
 Tc=6.0 min CN=88 Runoff=3.1 cfs 9,538 cf

Subcatchment PS2: Site Frontage by Runoff Area=9,757 sf 90.88% Impervious Runoff Depth=2.71"
 Tc=6.0 min CN=96 Runoff=0.6 cfs 2,203 cf

Reach DP1: Public Drainage System Inflow=15.7 cfs 51,450 cf
 Outflow=15.7 cfs 51,450 cf

Reach DP2: Catch Basin, Pearson St Inflow=0.6 cfs 2,203 cf
 Outflow=0.6 cfs 2,203 cf

Pond 1P: Peak Elev=92.52' Storage=2,497 cf Inflow=3.1 cfs 9,538 cf
 Discarded=0.0 cfs 3,553 cf Primary=1.6 cfs 5,986 cf Outflow=1.7 cfs 9,538 cf

Total Runoff Area = 313,796 sf Runoff Volume = 57,206 cf Average Runoff Depth = 2.19"
24.98% Pervious = 78,397 sf 75.02% Impervious = 235,399 sf

4145 Proposed

Summary for Subcatchment PS1: Proposed Site + Off-Site

Runoff = 14.3 cfs @ 12.13 hrs, Volume= 45,465 cf, Depth= 2.22"
 Routed to Reach DP1 : Public Drainage System

Runoff by SCS TR-20 method, UH=SCS, Weighted-CN, Time Span= 0.00-36.00 hrs, dt= 0.01 hrs
 NOAA 24-hr D 2-yr Rainfall=3.16"

Area (sf)	CN	Description
62,700	98	Paved parking, HSG B
73,101	98	Roofs, HSG B
* 31,313	79	Open Space (75-100% grass cover), HSG B
58,820	85	1/8 acre lots, 65% imp, HSG B
* 14,016	85	Gravel surface, HSG B "100% imp"
* 5,722	55	Woods
245,672	91	Weighted Average
57,622		23.45% Pervious Area
188,050		76.55% Impervious Area

Tc (min)	Length (feet)	Slope (ft/ft)	Velocity (ft/sec)	Capacity (cfs)	Description
6.0					Direct Entry, Adjustment to 0.1hr

Summary for Subcatchment PS1.1: Northern Parking + Dog Park + Off Site (1/8 acre residential lots)

Runoff = 3.1 cfs @ 12.13 hrs, Volume= 9,538 cf, Depth= 1.96"
 Routed to Pond 1P :

Runoff by SCS TR-20 method, UH=SCS, Weighted-CN, Time Span= 0.00-36.00 hrs, dt= 0.01 hrs
 NOAA 24-hr D 2-yr Rainfall=3.16"

Area (sf)	CN	Description
* 17,404	98	Paved parking, HSG B
* 8,536	79	Open Space (75-100% grass cover), HSG B
32,427	85	1/8 acre lots, 65% imp, HSG B
58,367	88	Weighted Average
19,885		34.07% Pervious Area
38,482		65.93% Impervious Area

Tc (min)	Length (feet)	Slope (ft/ft)	Velocity (ft/sec)	Capacity (cfs)	Description
6.0					Direct Entry, Adjustment to 0.1hr

Summary for Subcatchment PS2: Site Frontage by Pearson Street

Runoff = 0.6 cfs @ 12.13 hrs, Volume= 2,203 cf, Depth= 2.71"
 Routed to Reach DP2 : Catch Basin, Pearson St

Runoff by SCS TR-20 method, UH=SCS, Weighted-CN, Time Span= 0.00-36.00 hrs, dt= 0.01 hrs
 NOAA 24-hr D 2-yr Rainfall=3.16"

4145 Proposed

Prepared by The Morin-Cameron Group, Inc
 HydroCAD® 10.20-4a s/n 00401 © 2023 HydroCAD Software Solutions LLC

NOAA 24-hr D 2-yr Rainfall=3.16"

Printed 2/20/2024

Page 6

Area (sf)	CN	Description
8,492	98	Paved parking, HSG B
* 890	79	Open Space (75-100% grass cover), HSG B
* 375	85	Gravel surface, HSG B "100% imp"
9,757	96	Weighted Average
890		9.12% Pervious Area
8,867		90.88% Impervious Area

Tc (min)	Length (feet)	Slope (ft/ft)	Velocity (ft/sec)	Capacity (cfs)	Description
6.0					Direct Entry, Adjustment to 0.1hr

Summary for Reach DP1: Public Drainage System

Inflow Area = 304,039 sf, 74.51% Impervious, Inflow Depth = 2.03" for 2-yr event
 Inflow = 15.7 cfs @ 12.13 hrs, Volume= 51,450 cf
 Outflow = 15.7 cfs @ 12.13 hrs, Volume= 51,450 cf, Atten= 0%, Lag= 0.0 min

Routing by Dyn-Stor-Ind method, Time Span= 0.00-36.00 hrs, dt= 0.01 hrs

Summary for Reach DP2: Catch Basin, Pearson St

Inflow Area = 9,757 sf, 90.88% Impervious, Inflow Depth = 2.71" for 2-yr event
 Inflow = 0.6 cfs @ 12.13 hrs, Volume= 2,203 cf
 Outflow = 0.6 cfs @ 12.13 hrs, Volume= 2,203 cf, Atten= 0%, Lag= 0.0 min

Routing by Dyn-Stor-Ind method, Time Span= 0.00-36.00 hrs, dt= 0.01 hrs

Summary for Pond 1P:

Inflow Area = 58,367 sf, 65.93% Impervious, Inflow Depth = 1.96" for 2-yr event
 Inflow = 3.1 cfs @ 12.13 hrs, Volume= 9,538 cf
 Outflow = 1.7 cfs @ 12.22 hrs, Volume= 9,538 cf, Atten= 46%, Lag= 5.4 min
 Discarded = 0.0 cfs @ 12.22 hrs, Volume= 3,553 cf
 Primary = 1.6 cfs @ 12.22 hrs, Volume= 5,986 cf

Routed to Reach DP1 : Public Drainage System

Routing by Dyn-Stor-Ind method, Time Span= 0.00-36.00 hrs, dt= 0.01 hrs
 Peak Elev= 92.52' @ 12.22 hrs Surf.Area= 1,354 sf Storage= 2,497 cf

Plug-Flow detention time= 147.7 min calculated for 9,536 cf (100% of inflow)
 Center-of-Mass det. time= 147.8 min (971.7 - 823.9)

Volume	Invert	Avail.Storage	Storage Description
#1A	89.10'	2,273 cf	24.25'W x 55.83'L x 5.75'H Field A 7,785 cf Overall - 2,104 cf Embedded = 5,681 cf x 40.0% Voids
#2A	91.35'	2,104 cf	Cultec R-360HD x 56 Inside #1 Effective Size= 54.9"W x 36.0"H => 9.99 sf x 3.67'L = 36.6 cf Overall Size= 60.0"W x 36.0"H x 4.17'L with 0.50' Overlap 56 Chambers in 4 Rows Cap Storage= 6.5 cf x 2 x 4 rows = 51.7 cf

4145 Proposed

Prepared by The Morin-Cameron Group, Inc
HydroCAD® 10.20-4a s/n 00401 © 2023 HydroCAD Software Solutions LLC

NOAA 24-hr D 2-yr Rainfall=3.16"

Printed 2/20/2024

Page 7

4,376 cf Total Available Storage

Storage Group A created with Chamber Wizard

Device	Routing	Invert	Outlet Devices
#1	Primary	91.35'	18.0" Round 18" Outlet L= 39.0' CPP, projecting, no headwall, Ke= 0.900 Inlet / Outlet Invert= 91.35' / 90.55' S= 0.0205 ' S= 0.0205 ' Cc= 0.900 n= 0.012, Flow Area= 1.77 sf
#2	Device 1	91.35'	12.0" W x 4.0" H Vert. Orifice/Grate-2yr C= 0.600 Limited to weir flow at low heads
#3	Device 1	92.55'	6.0" Vert. Orifice/Grate-10yr X 3.00 C= 0.600 Limited to weir flow at low heads
#4	Device 1	93.45'	5.0" Vert. Orifice/Grate-25yr X 3.00 C= 0.600 Limited to weir flow at low heads
#5	Device 1	94.25'	4.0' long x 0.5' breadth Broad-Crested Rectangular Weir Head (feet) 0.20 0.40 0.60 0.80 1.00 Coef. (English) 2.80 2.92 3.08 3.30 3.32
#6	Discarded	89.10'	1.020 in/hr Exfiltration over Wetted area Phase-In= 0.01'

Discarded OutFlow Max=0.0 cfs @ 12.22 hrs HW=92.52' (Free Discharge)

↑ **6=Exfiltration** (Exfiltration Controls 0.0 cfs)

Primary OutFlow Max=1.6 cfs @ 12.22 hrs HW=92.52' TW=0.00' (Dynamic Tailwater)

↑ **1=18" Outlet** (Passes 1.6 cfs of 4.3 cfs potential flow)

↑ **2=Orifice/Grate-2yr** (Orifice Controls 1.6 cfs @ 4.83 fps)

↑ **3=Orifice/Grate-10yr** (Controls 0.0 cfs)

↑ **4=Orifice/Grate-25yr** (Controls 0.0 cfs)

↑ **5=Broad-Crested Rectangular Weir** (Controls 0.0 cfs)

4145 Proposed

NOAA 24-hr D 10-yr Rainfall=5.01"

Prepared by The Morin-Cameron Group, Inc

Printed 2/20/2024

HydroCAD® 10.20-4a s/n 00401 © 2023 HydroCAD Software Solutions LLC

Page 8

Time span=0.00-36.00 hrs, dt=0.01 hrs, 3601 points
 Runoff by SCS TR-20 method, UH=SCS, Weighted-CN
 Reach routing by Dyn-Stor-Ind method - Pond routing by Dyn-Stor-Ind method

Subcatchment PS1: Proposed Site + Runoff Area=245,672 sf 76.55% Impervious Runoff Depth=3.99"
 Tc=6.0 min CN=91 Runoff=24.8 cfs 81,723 cf

Subcatchment PS1.1: Northern Parking + Runoff Area=58,367 sf 65.93% Impervious Runoff Depth=3.68"
 Tc=6.0 min CN=88 Runoff=5.6 cfs 17,892 cf

Subcatchment PS2: Site Frontage by Runoff Area=9,757 sf 90.88% Impervious Runoff Depth=4.54"
 Tc=6.0 min CN=96 Runoff=1.1 cfs 3,693 cf

Reach DP1: Public Drainage System Inflow=28.6 cfs 95,696 cf
 Outflow=28.6 cfs 95,696 cf

Reach DP2: Catch Basin, Pearson St Inflow=1.1 cfs 3,693 cf
 Outflow=1.1 cfs 3,693 cf

Pond 1P: Peak Elev=93.35' Storage=3,319 cf Inflow=5.6 cfs 17,892 cf
 Discarded=0.0 cfs 3,918 cf Primary=4.3 cfs 13,973 cf Outflow=4.3 cfs 17,892 cf

Total Runoff Area = 313,796 sf Runoff Volume = 103,308 cf Average Runoff Depth = 3.95"
24.98% Pervious = 78,397 sf 75.02% Impervious = 235,399 sf

4145 Proposed

NOAA 24-hr D 10-yr Rainfall=5.01"

Prepared by The Morin-Cameron Group, Inc

Printed 2/20/2024

HydroCAD® 10.20-4a s/n 00401 © 2023 HydroCAD Software Solutions LLC

Page 9

Summary for Subcatchment PS1: Proposed Site + Off-Site

Runoff = 24.8 cfs @ 12.13 hrs, Volume= 81,723 cf, Depth= 3.99"
Routed to Reach DP1 : Public Drainage System

Runoff by SCS TR-20 method, UH=SCS, Weighted-CN, Time Span= 0.00-36.00 hrs, dt= 0.01 hrs
NOAA 24-hr D 10-yr Rainfall=5.01"

Area (sf)	CN	Description
62,700	98	Paved parking, HSG B
73,101	98	Roofs, HSG B
* 31,313	79	Open Space (75-100% grass cover), HSG B
58,820	85	1/8 acre lots, 65% imp, HSG B
* 14,016	85	Gravel surface, HSG B "100% imp"
* 5,722	55	Woods
245,672	91	Weighted Average
57,622		23.45% Pervious Area
188,050		76.55% Impervious Area

Tc (min)	Length (feet)	Slope (ft/ft)	Velocity (ft/sec)	Capacity (cfs)	Description
6.0					Direct Entry, Adjustment to 0.1hr

Summary for Subcatchment PS1.1: Northern Parking + Dog Park + Off Site (1/8 acre residential lots)

Runoff = 5.6 cfs @ 12.13 hrs, Volume= 17,892 cf, Depth= 3.68"
Routed to Pond 1P :

Runoff by SCS TR-20 method, UH=SCS, Weighted-CN, Time Span= 0.00-36.00 hrs, dt= 0.01 hrs
NOAA 24-hr D 10-yr Rainfall=5.01"

Area (sf)	CN	Description
* 17,404	98	Paved parking, HSG B
* 8,536	79	Open Space (75-100% grass cover), HSG B
32,427	85	1/8 acre lots, 65% imp, HSG B
58,367	88	Weighted Average
19,885		34.07% Pervious Area
38,482		65.93% Impervious Area

Tc (min)	Length (feet)	Slope (ft/ft)	Velocity (ft/sec)	Capacity (cfs)	Description
6.0					Direct Entry, Adjustment to 0.1hr

Summary for Subcatchment PS2: Site Frontage by Pearson Street

Runoff = 1.1 cfs @ 12.13 hrs, Volume= 3,693 cf, Depth= 4.54"
Routed to Reach DP2 : Catch Basin, Pearson St

Runoff by SCS TR-20 method, UH=SCS, Weighted-CN, Time Span= 0.00-36.00 hrs, dt= 0.01 hrs
NOAA 24-hr D 10-yr Rainfall=5.01"

4145 Proposed

Prepared by The Morin-Cameron Group, Inc
 HydroCAD® 10.20-4a s/n 00401 © 2023 HydroCAD Software Solutions LLC

NOAA 24-hr D 10-yr Rainfall=5.01"

Printed 2/20/2024

Page 10

Area (sf)	CN	Description
8,492	98	Paved parking, HSG B
* 890	79	Open Space (75-100% grass cover), HSG B
* 375	85	Gravel surface, HSG B "100% imp"
9,757	96	Weighted Average
890		9.12% Pervious Area
8,867		90.88% Impervious Area

Tc (min)	Length (feet)	Slope (ft/ft)	Velocity (ft/sec)	Capacity (cfs)	Description
6.0					Direct Entry, Adjustment to 0.1hr

Summary for Reach DP1: Public Drainage System

Inflow Area = 304,039 sf, 74.51% Impervious, Inflow Depth = 3.78" for 10-yr event
 Inflow = 28.6 cfs @ 12.13 hrs, Volume= 95,696 cf
 Outflow = 28.6 cfs @ 12.13 hrs, Volume= 95,696 cf, Atten= 0%, Lag= 0.0 min

Routing by Dyn-Stor-Ind method, Time Span= 0.00-36.00 hrs, dt= 0.01 hrs

Summary for Reach DP2: Catch Basin, Pearson St

Inflow Area = 9,757 sf, 90.88% Impervious, Inflow Depth = 4.54" for 10-yr event
 Inflow = 1.1 cfs @ 12.13 hrs, Volume= 3,693 cf
 Outflow = 1.1 cfs @ 12.13 hrs, Volume= 3,693 cf, Atten= 0%, Lag= 0.0 min

Routing by Dyn-Stor-Ind method, Time Span= 0.00-36.00 hrs, dt= 0.01 hrs

Summary for Pond 1P:

Inflow Area = 58,367 sf, 65.93% Impervious, Inflow Depth = 3.68" for 10-yr event
 Inflow = 5.6 cfs @ 12.13 hrs, Volume= 17,892 cf
 Outflow = 4.3 cfs @ 12.18 hrs, Volume= 17,892 cf, Atten= 22%, Lag= 2.9 min
 Discarded = 0.0 cfs @ 12.18 hrs, Volume= 3,918 cf
 Primary = 4.3 cfs @ 12.18 hrs, Volume= 13,973 cf

Routed to Reach DP1 : Public Drainage System

Routing by Dyn-Stor-Ind method, Time Span= 0.00-36.00 hrs, dt= 0.01 hrs
 Peak Elev= 93.35' @ 12.18 hrs Surf.Area= 1,354 sf Storage= 3,319 cf

Plug-Flow detention time= 91.4 min calculated for 17,887 cf (100% of inflow)
 Center-of-Mass det. time= 91.6 min (895.7 - 804.2)

Volume	Invert	Avail.Storage	Storage Description
#1A	89.10'	2,273 cf	24.25'W x 55.83'L x 5.75'H Field A 7,785 cf Overall - 2,104 cf Embedded = 5,681 cf x 40.0% Voids
#2A	91.35'	2,104 cf	Cultec R-360HD x 56 Inside #1 Effective Size= 54.9"W x 36.0"H => 9.99 sf x 3.67'L = 36.6 cf Overall Size= 60.0"W x 36.0"H x 4.17'L with 0.50' Overlap 56 Chambers in 4 Rows Cap Storage= 6.5 cf x 2 x 4 rows = 51.7 cf

4145 Proposed

Prepared by The Morin-Cameron Group, Inc

HydroCAD® 10.20-4a s/n 00401 © 2023 HydroCAD Software Solutions LLC

NOAA 24-hr D 10-yr Rainfall=5.01"

Printed 2/20/2024

Page 11

4,376 cf Total Available Storage

Storage Group A created with Chamber Wizard

Device	Routing	Invert	Outlet Devices
#1	Primary	91.35'	18.0" Round 18" Outlet L= 39.0' CPP, projecting, no headwall, Ke= 0.900 Inlet / Outlet Invert= 91.35' / 90.55' S= 0.0205 '/' Cc= 0.900 n= 0.012, Flow Area= 1.77 sf
#2	Device 1	91.35'	12.0" W x 4.0" H Vert. Orifice/Grate-2yr C= 0.600 Limited to weir flow at low heads
#3	Device 1	92.55'	6.0" Vert. Orifice/Grate-10yr X 3.00 C= 0.600 Limited to weir flow at low heads
#4	Device 1	93.45'	5.0" Vert. Orifice/Grate-25yr X 3.00 C= 0.600 Limited to weir flow at low heads
#5	Device 1	94.25'	4.0' long x 0.5' breadth Broad-Crested Rectangular Weir Head (feet) 0.20 0.40 0.60 0.80 1.00 Coef. (English) 2.80 2.92 3.08 3.30 3.32
#6	Discarded	89.10'	1.020 in/hr Exfiltration over Wetted area Phase-In= 0.01'

Discarded OutFlow Max=0.0 cfs @ 12.18 hrs HW=93.35' (Free Discharge)

↳ **6=Exfiltration** (Exfiltration Controls 0.0 cfs)

Primary OutFlow Max=4.3 cfs @ 12.18 hrs HW=93.35' TW=0.00' (Dynamic Tailwater)

↳ **1=18" Outlet** (Passes 4.3 cfs of 7.5 cfs potential flow)

↳ **2=Orifice/Grate-2yr** (Orifice Controls 2.2 cfs @ 6.51 fps)

↳ **3=Orifice/Grate-10yr** (Orifice Controls 2.1 cfs @ 3.56 fps)

↳ **4=Orifice/Grate-25yr** (Controls 0.0 cfs)

↳ **5=Broad-Crested Rectangular Weir** (Controls 0.0 cfs)

4145 Proposed

NOAA 24-hr D 25-yr Rainfall=6.16"

Prepared by The Morin-Cameron Group, Inc

Printed 2/20/2024

HydroCAD® 10.20-4a s/n 00401 © 2023 HydroCAD Software Solutions LLC

Page 12

Time span=0.00-36.00 hrs, dt=0.01 hrs, 3601 points
Runoff by SCS TR-20 method, UH=SCS, Weighted-CN
Reach routing by Dyn-Stor-Ind method - Pond routing by Dyn-Stor-Ind method

Subcatchment PS1: Proposed Site + Runoff Area=245,672 sf 76.55% Impervious Runoff Depth=5.11"
Tc=6.0 min CN=91 Runoff=31.3 cfs 104,695 cf

Subcatchment PS1.1: Northern Parking + Runoff Area=58,367 sf 65.93% Impervious Runoff Depth=4.78"
Tc=6.0 min CN=88 Runoff=7.1 cfs 23,250 cf

Subcatchment PS2: Site Frontage by Runoff Area=9,757 sf 90.88% Impervious Runoff Depth=5.69"
Tc=6.0 min CN=96 Runoff=1.3 cfs 4,624 cf

Reach DP1: Public Drainage System Inflow=36.4 cfs 123,863 cf
Outflow=36.4 cfs 123,863 cf

Reach DP2: Catch Basin, Pearson St Inflow=1.3 cfs 4,624 cf
Outflow=1.3 cfs 4,624 cf

Pond 1P: Peak Elev=93.78' Storage=3,706 cf Inflow=7.1 cfs 23,250 cf
Discarded=0.0 cfs 4,082 cf Primary=5.9 cfs 19,168 cf Outflow=6.0 cfs 23,250 cf

Total Runoff Area = 313,796 sf Runoff Volume = 132,569 cf Average Runoff Depth = 5.07"
24.98% Pervious = 78,397 sf 75.02% Impervious = 235,399 sf

4145 Proposed

Prepared by The Morin-Cameron Group, Inc

HydroCAD® 10.20-4a s/n 00401 © 2023 HydroCAD Software Solutions LLC

NOAA 24-hr D 25-yr Rainfall=6.16"

Printed 2/20/2024

Page 13

Summary for Subcatchment PS1: Proposed Site + Off-Site

Runoff = 31.3 cfs @ 12.13 hrs, Volume= 104,695 cf, Depth= 5.11"

Routed to Reach DP1 : Public Drainage System

Runoff by SCS TR-20 method, UH=SCS, Weighted-CN, Time Span= 0.00-36.00 hrs, dt= 0.01 hrs
NOAA 24-hr D 25-yr Rainfall=6.16"

Area (sf)	CN	Description
62,700	98	Paved parking, HSG B
73,101	98	Roofs, HSG B
* 31,313	79	Open Space (75-100% grass cover), HSG B
58,820	85	1/8 acre lots, 65% imp, HSG B
* 14,016	85	Gravel surface, HSG B "100% imp"
* 5,722	55	Woods
245,672	91	Weighted Average
57,622		23.45% Pervious Area
188,050		76.55% Impervious Area

Tc (min)	Length (feet)	Slope (ft/ft)	Velocity (ft/sec)	Capacity (cfs)	Description
6.0					Direct Entry, Adjustment to 0.1hr

Summary for Subcatchment PS1.1: Northern Parking + Dog Park + Off Site (1/8 acre residential lots)

Runoff = 7.1 cfs @ 12.13 hrs, Volume= 23,250 cf, Depth= 4.78"

Routed to Pond 1P :

Runoff by SCS TR-20 method, UH=SCS, Weighted-CN, Time Span= 0.00-36.00 hrs, dt= 0.01 hrs
NOAA 24-hr D 25-yr Rainfall=6.16"

Area (sf)	CN	Description
* 17,404	98	Paved parking, HSG B
* 8,536	79	Open Space (75-100% grass cover), HSG B
32,427	85	1/8 acre lots, 65% imp, HSG B
58,367	88	Weighted Average
19,885		34.07% Pervious Area
38,482		65.93% Impervious Area

Tc (min)	Length (feet)	Slope (ft/ft)	Velocity (ft/sec)	Capacity (cfs)	Description
6.0					Direct Entry, Adjustment to 0.1hr

Summary for Subcatchment PS2: Site Frontage by Pearson Street

Runoff = 1.3 cfs @ 12.13 hrs, Volume= 4,624 cf, Depth= 5.69"

Routed to Reach DP2 : Catch Basin, Pearson St

Runoff by SCS TR-20 method, UH=SCS, Weighted-CN, Time Span= 0.00-36.00 hrs, dt= 0.01 hrs
NOAA 24-hr D 25-yr Rainfall=6.16"

4145 Proposed

Prepared by The Morin-Cameron Group, Inc
 HydroCAD® 10.20-4a s/n 00401 © 2023 HydroCAD Software Solutions LLC

NOAA 24-hr D 25-yr Rainfall=6.16"

Printed 2/20/2024

Page 14

Area (sf)	CN	Description
8,492	98	Paved parking, HSG B
* 890	79	Open Space (75-100% grass cover), HSG B
* 375	85	Gravel surface, HSG B "100% imp"
9,757	96	Weighted Average
890		9.12% Pervious Area
8,867		90.88% Impervious Area

Tc (min)	Length (feet)	Slope (ft/ft)	Velocity (ft/sec)	Capacity (cfs)	Description
6.0					Direct Entry, Adjustment to 0.1hr

Summary for Reach DP1: Public Drainage System

Inflow Area = 304,039 sf, 74.51% Impervious, Inflow Depth = 4.89" for 25-yr event
 Inflow = 36.4 cfs @ 12.13 hrs, Volume= 123,863 cf
 Outflow = 36.4 cfs @ 12.13 hrs, Volume= 123,863 cf, Atten= 0%, Lag= 0.0 min

Routing by Dyn-Stor-Ind method, Time Span= 0.00-36.00 hrs, dt= 0.01 hrs

Summary for Reach DP2: Catch Basin, Pearson St

Inflow Area = 9,757 sf, 90.88% Impervious, Inflow Depth = 5.69" for 25-yr event
 Inflow = 1.3 cfs @ 12.13 hrs, Volume= 4,624 cf
 Outflow = 1.3 cfs @ 12.13 hrs, Volume= 4,624 cf, Atten= 0%, Lag= 0.0 min

Routing by Dyn-Stor-Ind method, Time Span= 0.00-36.00 hrs, dt= 0.01 hrs

Summary for Pond 1P:

Inflow Area = 58,367 sf, 65.93% Impervious, Inflow Depth = 4.78" for 25-yr event
 Inflow = 7.1 cfs @ 12.13 hrs, Volume= 23,250 cf
 Outflow = 6.0 cfs @ 12.17 hrs, Volume= 23,250 cf, Atten= 16%, Lag= 2.4 min
 Discarded = 0.0 cfs @ 12.17 hrs, Volume= 4,082 cf
 Primary = 5.9 cfs @ 12.17 hrs, Volume= 19,168 cf

Routed to Reach DP1 : Public Drainage System

Routing by Dyn-Stor-Ind method, Time Span= 0.00-36.00 hrs, dt= 0.01 hrs
 Peak Elev= 93.78' @ 12.17 hrs Surf.Area= 1,354 sf Storage= 3,706 cf

Plug-Flow detention time= 75.9 min calculated for 23,243 cf (100% of inflow)
 Center-of-Mass det. time= 76.0 min (872.1 - 796.1)

Volume	Invert	Avail.Storage	Storage Description
#1A	89.10'	2,273 cf	24.25'W x 55.83'L x 5.75'H Field A 7,785 cf Overall - 2,104 cf Embedded = 5,681 cf x 40.0% Voids
#2A	91.35'	2,104 cf	Cultec R-360HD x 56 Inside #1 Effective Size= 54.9"W x 36.0"H => 9.99 sf x 3.67'L = 36.6 cf Overall Size= 60.0"W x 36.0"H x 4.17'L with 0.50' Overlap 56 Chambers in 4 Rows Cap Storage= 6.5 cf x 2 x 4 rows = 51.7 cf

4145 Proposed

Prepared by The Morin-Cameron Group, Inc

HydroCAD® 10.20-4a s/n 00401 © 2023 HydroCAD Software Solutions LLC

NOAA 24-hr D 25-yr Rainfall=6.16"

Printed 2/20/2024

Page 15

4,376 cf Total Available Storage

Storage Group A created with Chamber Wizard

Device	Routing	Invert	Outlet Devices
#1	Primary	91.35'	18.0" Round 18" Outlet L= 39.0' CPP, projecting, no headwall, Ke= 0.900 Inlet / Outlet Invert= 91.35' / 90.55' S= 0.0205 ' S= 0.0205 ' Cc= 0.900 n= 0.012, Flow Area= 1.77 sf
#2	Device 1	91.35'	12.0" W x 4.0" H Vert. Orifice/Grate-2yr C= 0.600 Limited to weir flow at low heads
#3	Device 1	92.55'	6.0" Vert. Orifice/Grate-10yr X 3.00 C= 0.600 Limited to weir flow at low heads
#4	Device 1	93.45'	5.0" Vert. Orifice/Grate-25yr X 3.00 C= 0.600 Limited to weir flow at low heads
#5	Device 1	94.25'	4.0' long x 0.5' breadth Broad-Crested Rectangular Weir Head (feet) 0.20 0.40 0.60 0.80 1.00 Coef. (English) 2.80 2.92 3.08 3.30 3.32
#6	Discarded	89.10'	1.020 in/hr Exfiltration over Wetted area Phase-In= 0.01'

Discarded OutFlow Max=0.0 cfs @ 12.17 hrs HW=93.78' (Free Discharge)

↳ **6=Exfiltration** (Exfiltration Controls 0.0 cfs)

Primary OutFlow Max=5.9 cfs @ 12.17 hrs HW=93.78' TW=0.00' (Dynamic Tailwater)

↳ **1=18" Outlet** (Passes 5.9 cfs of 8.7 cfs potential flow)

↳ **2=Orifice/Grate-2yr** (Orifice Controls 2.4 cfs @ 7.25 fps)

↳ **3=Orifice/Grate-10yr** (Orifice Controls 2.8 cfs @ 4.77 fps)

↳ **4=Orifice/Grate-25yr** (Orifice Controls 0.7 cfs @ 1.96 fps)

↳ **5=Broad-Crested Rectangular Weir** (Controls 0.0 cfs)

4145 Proposed

NOAA 24-hr D 100-yr Rainfall=7.94"

Prepared by The Morin-Cameron Group, Inc

Printed 2/20/2024

HydroCAD® 10.20-4a s/n 00401 © 2023 HydroCAD Software Solutions LLC

Page 16

Time span=0.00-36.00 hrs, dt=0.01 hrs, 3601 points
 Runoff by SCS TR-20 method, UH=SCS, Weighted-CN
 Reach routing by Dyn-Stor-Ind method - Pond routing by Dyn-Stor-Ind method

Subcatchment PS1: Proposed Site + Runoff Area=245,672 sf 76.55% Impervious Runoff Depth=6.87"
 Tc=6.0 min CN=91 Runoff=41.2 cfs 140,549 cf

Subcatchment PS1.1: Northern Parking + Runoff Area=58,367 sf 65.93% Impervious Runoff Depth=6.51"
 Tc=6.0 min CN=88 Runoff=9.5 cfs 31,662 cf

Subcatchment PS2: Site Frontage by Runoff Area=9,757 sf 90.88% Impervious Runoff Depth=7.46"
 Tc=6.0 min CN=96 Runoff=1.7 cfs 6,066 cf

Reach DP1: Public Drainage System Inflow=48.9 cfs 167,945 cf
 Outflow=48.9 cfs 167,945 cf

Reach DP2: Catch Basin, Pearson St Inflow=1.7 cfs 6,066 cf
 Outflow=1.7 cfs 6,066 cf

Pond 1P: Peak Elev=94.40' Storage=4,133 cf Inflow=9.5 cfs 31,662 cf
 Discarded=0.1 cfs 4,266 cf Primary=8.7 cfs 27,396 cf Outflow=8.7 cfs 31,662 cf

Total Runoff Area = 313,796 sf Runoff Volume = 178,278 cf Average Runoff Depth = 6.82"
24.98% Pervious = 78,397 sf 75.02% Impervious = 235,399 sf

4145 Proposed

NOAA 24-hr D 100-yr Rainfall=7.94"

Prepared by The Morin-Cameron Group, Inc

Printed 2/20/2024

HydroCAD® 10.20-4a s/n 00401 © 2023 HydroCAD Software Solutions LLC

Page 17

Summary for Subcatchment PS1: Proposed Site + Off-Site

Runoff = 41.2 cfs @ 12.13 hrs, Volume= 140,549 cf, Depth= 6.87"

Routed to Reach DP1 : Public Drainage System

Runoff by SCS TR-20 method, UH=SCS, Weighted-CN, Time Span= 0.00-36.00 hrs, dt= 0.01 hrs
NOAA 24-hr D 100-yr Rainfall=7.94"

Area (sf)	CN	Description
62,700	98	Paved parking, HSG B
73,101	98	Roofs, HSG B
* 31,313	79	Open Space (75-100% grass cover), HSG B
58,820	85	1/8 acre lots, 65% imp, HSG B
* 14,016	85	Gravel surface, HSG B "100% imp"
* 5,722	55	Woods
245,672	91	Weighted Average
57,622		23.45% Pervious Area
188,050		76.55% Impervious Area

Tc (min)	Length (feet)	Slope (ft/ft)	Velocity (ft/sec)	Capacity (cfs)	Description
6.0					Direct Entry, Adjustment to 0.1hr

Summary for Subcatchment PS1.1: Northern Parking + Dog Park + Off Site (1/8 acre residential lots)

Runoff = 9.5 cfs @ 12.13 hrs, Volume= 31,662 cf, Depth= 6.51"

Routed to Pond 1P :

Runoff by SCS TR-20 method, UH=SCS, Weighted-CN, Time Span= 0.00-36.00 hrs, dt= 0.01 hrs
NOAA 24-hr D 100-yr Rainfall=7.94"

Area (sf)	CN	Description
* 17,404	98	Paved parking, HSG B
* 8,536	79	Open Space (75-100% grass cover), HSG B
32,427	85	1/8 acre lots, 65% imp, HSG B
58,367	88	Weighted Average
19,885		34.07% Pervious Area
38,482		65.93% Impervious Area

Tc (min)	Length (feet)	Slope (ft/ft)	Velocity (ft/sec)	Capacity (cfs)	Description
6.0					Direct Entry, Adjustment to 0.1hr

Summary for Subcatchment PS2: Site Frontage by Pearson Street

Runoff = 1.7 cfs @ 12.13 hrs, Volume= 6,066 cf, Depth= 7.46"

Routed to Reach DP2 : Catch Basin, Pearson St

Runoff by SCS TR-20 method, UH=SCS, Weighted-CN, Time Span= 0.00-36.00 hrs, dt= 0.01 hrs
NOAA 24-hr D 100-yr Rainfall=7.94"

4145 Proposed

NOAA 24-hr D 100-yr Rainfall=7.94"

Prepared by The Morin-Cameron Group, Inc

Printed 2/20/2024

HydroCAD® 10.20-4a s/n 00401 © 2023 HydroCAD Software Solutions LLC

Page 18

Area (sf)	CN	Description
8,492	98	Paved parking, HSG B
* 890	79	Open Space (75-100% grass cover), HSG B
* 375	85	Gravel surface, HSG B "100% imp"
9,757	96	Weighted Average
890		9.12% Pervious Area
8,867		90.88% Impervious Area

Tc (min)	Length (feet)	Slope (ft/ft)	Velocity (ft/sec)	Capacity (cfs)	Description
6.0					Direct Entry, Adjustment to 0.1hr

Summary for Reach DP1: Public Drainage System

Inflow Area = 304,039 sf, 74.51% Impervious, Inflow Depth = 6.63" for 100-yr event
 Inflow = 48.9 cfs @ 12.14 hrs, Volume= 167,945 cf
 Outflow = 48.9 cfs @ 12.14 hrs, Volume= 167,945 cf, Atten= 0%, Lag= 0.0 min

Routing by Dyn-Stor-Ind method, Time Span= 0.00-36.00 hrs, dt= 0.01 hrs

Summary for Reach DP2: Catch Basin, Pearson St

Inflow Area = 9,757 sf, 90.88% Impervious, Inflow Depth = 7.46" for 100-yr event
 Inflow = 1.7 cfs @ 12.13 hrs, Volume= 6,066 cf
 Outflow = 1.7 cfs @ 12.13 hrs, Volume= 6,066 cf, Atten= 0%, Lag= 0.0 min

Routing by Dyn-Stor-Ind method, Time Span= 0.00-36.00 hrs, dt= 0.01 hrs

Summary for Pond 1P:

Inflow Area = 58,367 sf, 65.93% Impervious, Inflow Depth = 6.51" for 100-yr event
 Inflow = 9.5 cfs @ 12.13 hrs, Volume= 31,662 cf
 Outflow = 8.7 cfs @ 12.16 hrs, Volume= 31,662 cf, Atten= 8%, Lag= 1.7 min
 Discarded = 0.1 cfs @ 12.16 hrs, Volume= 4,266 cf
 Primary = 8.7 cfs @ 12.16 hrs, Volume= 27,396 cf

Routed to Reach DP1 : Public Drainage System

Routing by Dyn-Stor-Ind method, Time Span= 0.00-36.00 hrs, dt= 0.01 hrs
 Peak Elev= 94.40' @ 12.16 hrs Surf.Area= 1,354 sf Storage= 4,133 cf

Plug-Flow detention time= 61.5 min calculated for 31,662 cf (100% of inflow)
 Center-of-Mass det. time= 61.5 min (848.4 - 786.9)

Volume	Invert	Avail.Storage	Storage Description
#1A	89.10'	2,273 cf	24.25'W x 55.83'L x 5.75'H Field A 7,785 cf Overall - 2,104 cf Embedded = 5,681 cf x 40.0% Voids
#2A	91.35'	2,104 cf	Cultec R-360HD x 56 Inside #1 Effective Size= 54.9"W x 36.0"H => 9.99 sf x 3.67'L = 36.6 cf Overall Size= 60.0"W x 36.0"H x 4.17'L with 0.50' Overlap 56 Chambers in 4 Rows Cap Storage= 6.5 cf x 2 x 4 rows = 51.7 cf

4145 Proposed

Prepared by The Morin-Cameron Group, Inc

HydroCAD® 10.20-4a s/n 00401 © 2023 HydroCAD Software Solutions LLC

NOAA 24-hr D 100-yr Rainfall=7.94"

Printed 2/20/2024

Page 19

4,376 cf Total Available Storage

Storage Group A created with Chamber Wizard

Device	Routing	Invert	Outlet Devices
#1	Primary	91.35'	18.0" Round 18" Outlet L= 39.0' CPP, projecting, no headwall, Ke= 0.900 Inlet / Outlet Invert= 91.35' / 90.55' S= 0.0205 '/' Cc= 0.900 n= 0.012, Flow Area= 1.77 sf
#2	Device 1	91.35'	12.0" W x 4.0" H Vert. Orifice/Grate-2yr C= 0.600 Limited to weir flow at low heads
#3	Device 1	92.55'	6.0" Vert. Orifice/Grate-10yr X 3.00 C= 0.600 Limited to weir flow at low heads
#4	Device 1	93.45'	5.0" Vert. Orifice/Grate-25yr X 3.00 C= 0.600 Limited to weir flow at low heads
#5	Device 1	94.25'	4.0' long x 0.5' breadth Broad-Crested Rectangular Weir Head (feet) 0.20 0.40 0.60 0.80 1.00 Coef. (English) 2.80 2.92 3.08 3.30 3.32
#6	Discarded	89.10'	1.020 in/hr Exfiltration over Wetted area Phase-In= 0.01'

Discarded OutFlow Max=0.1 cfs @ 12.16 hrs HW=94.40' (Free Discharge)

↳ **6=Exfiltration** (Exfiltration Controls 0.1 cfs)

Primary OutFlow Max=8.6 cfs @ 12.16 hrs HW=94.40' TW=0.00' (Dynamic Tailwater)

↳ **1=18" Outlet** (Passes 8.6 cfs of 10.2 cfs potential flow)

↳ **2=Orifice/Grate-2yr** (Orifice Controls 2.7 cfs @ 8.17 fps)

↳ **3=Orifice/Grate-10yr** (Orifice Controls 3.6 cfs @ 6.09 fps)

↳ **4=Orifice/Grate-25yr** (Orifice Controls 1.7 cfs @ 4.14 fps)

↳ **5=Broad-Crested Rectangular Weir** (Weir Controls 0.6 cfs @ 1.08 fps)

**APPENDIX D:
SUPPLEMENTAL STORMWATER
MANAGEMENT CALCULATIONS**

Stormwater Management Calculations

STANDARD 3: Recharge To Groundwater: Static Method

- Calculate Impervious Area (*From HydroCAD Model*)

Description	Existing Impervious Area	Proposed Impervious Area
Paved Parking	122,150	88,596
Roof	35,033	73,101
Total:	157,183	161,697

This project development will be increasing the impervious areas by 4,514 S.F.

- Determine Rainfall Depth to be Recharged:
(*MassDEP Stormwater Management Handbook: Table 2.3.2*)

Hydrologic Soil Group	Recharge Rainfall Depth
B	0.35"

- Calculate Recharge Volume
 - 'Rv' = [0.35" x 4,514 SF]
 - 'Rv' = [1454 SF] / 12 SF-In = 121.16 CF
 - 'Rv' = 122 CF**

- Calculate Provided Recharge
Proposed Recharge System provided in infiltration basin

HCAD System ID	Bottom of System	Lowest System Outlet	Total Recharge Volume Provided
Bottom of System	91.35	91.35	1,219

Recharge volume provided measured to lowest system outlet. See table attached.

Verify Drawdown, Maximum 72-Hours: Static Method

HCAD System ID	Recharge Volume (CF)	Bottom Surface Area (SF)	Infiltration Rate Inches/Hour	Drawdown Time Rv / (K x A) (Hours)	Description
1P	1,219	1,354	1.02	10.3	Subsurface Chambers

*****Design Complies with Recharge Volume Standard*****

STANDARD 4: Water Quality Volume

The Town of Andover Stormwater Management and Erosion Control Bylaw, section IX.D.1 requires 50% removal of Total Phosphorous and 80% of Total Suspended Solids from redevelopment sites. The proposed redevelopment will utilize two water quality units to remove TSS, see calculations attached.

For Total Phosphorous, the section IX.D.1.a.(2) specify two methods to meet the pollutant removal requirement, the installation of BMPs that meet the pollutant removal percentages, and/or retaining the volume equivalent or greater than 0.8 inches multiplied by the total post impervious area.

The proposed redevelopment project will utilize a Jellyfish Tank from Contech, that will remove TP up to 75% for a portion of the site. The other portion of the site, the volume retention method will be utilized. See calculation below.

Proposed Post Impervious on-site area from subcatchment PS1.1= 17,404 sf

Required Volume = 0.8 in x 17,404 sf = 1,160.26 = 1,161 cf

Total Retained volume = 1,219 cf (See table attached)

4145 Proposed

Prepared by The Morin-Cameron Group, Inc

HydroCAD® 10.20-4a s/n 00401 © 2023 HydroCAD Software Solutions LLC

NOAA 24-hr D 100-yr Rainfall=7.94"

Printed 2/21/2024

Stage-Area-Storage for Pond 1P: (continued)

Elevation (feet)	Wetted (sq-ft)	Storage (cubic-feet)	Elevation (feet)	Wetted (sq-ft)	Storage (cubic-feet)
91.22	1,694	1,148	91.75	1,778	1,663
91.23	1,695	1,154	91.76	1,780	1,674
91.24	1,697	1,159	91.77	1,782	1,685
91.25	1,698	1,164	91.78	1,783	1,696
91.26	1,700	1,170	91.79	1,785	1,707
91.27	1,702	1,175	91.80	1,786	1,718
91.28	1,703	1,181	91.81	1,788	1,729
91.29	1,705	1,186	91.82	1,790	1,740
91.30	1,706	1,191	91.83	1,791	1,751
91.31	1,708	1,197	91.84	1,793	1,762
91.32	1,710	1,202	91.85	1,794	1,773
91.33	1,711	1,208	91.86	1,796	1,784
91.34	1,713	1,213	91.87	1,798	1,795
91.35	1,714	1,219	91.88	1,799	1,806
91.36	1,716	1,230	91.89	1,801	1,817
91.37	1,718	1,241	91.90	1,802	1,828
91.38	1,719	1,252	91.91	1,804	1,839
91.39	1,721	1,263	91.92	1,806	1,850
91.40	1,722	1,274	91.93	1,807	1,861
91.41	1,724	1,286	91.94	1,809	1,872
91.42	1,726	1,297	91.95	1,810	1,883
91.43	1,727	1,308	91.96	1,812	1,894
91.44	1,729	1,319	91.97	1,814	1,905
91.45	1,730	1,330	91.98	1,815	1,915
91.46	1,732	1,342	91.99	1,817	1,926
91.47	1,734	1,353	92.00	1,818	1,937
91.48	1,735	1,364	92.01	1,820	1,948
91.49	1,737	1,375	92.02	1,822	1,959
91.50	1,738	1,386	92.03	1,823	1,970
91.51	1,740	1,397	92.04	1,825	1,981
91.52	1,742	1,408	92.05	1,826	1,991
91.53	1,743	1,420	92.06	1,828	2,002
91.54	1,745	1,431	92.07	1,830	2,013
91.55	1,746	1,442	92.08	1,831	2,024
91.56	1,748	1,453	92.09	1,833	2,035
91.57	1,750	1,464	92.10	1,834	2,046
91.58	1,751	1,475	92.11	1,836	2,056
91.59	1,753	1,486	92.12	1,838	2,067
91.60	1,754	1,497	92.13	1,839	2,078
91.61	1,756	1,508	92.14	1,841	2,089
91.62	1,758	1,520	92.15	1,842	2,100
91.63	1,759	1,531	92.16	1,844	2,110
91.64	1,761	1,542	92.17	1,846	2,121
91.65	1,762	1,553	92.18	1,847	2,132
91.66	1,764	1,564	92.19	1,849	2,143
91.67	1,766	1,575	92.20	1,850	2,153
91.68	1,767	1,586	92.21	1,852	2,164
91.69	1,769	1,597	92.22	1,854	2,175
91.70	1,770	1,608	92.23	1,855	2,186
91.71	1,772	1,619	92.24	1,857	2,196
91.72	1,774	1,630	92.25	1,858	2,207
91.73	1,775	1,641	92.26	1,860	2,218
91.74	1,777	1,652	92.27	1,862	2,228

Estimated Net Annual Solids Load Reduction
Based on the Rational Rainfall Method



ANDOVER TOWN YARD
ANDOVER, MA
WQU 2



AREA	0.90	acres	CASCADE MODEL	CS-4	
WEIGHTED C	0.95		PARTICLE SIZE	110	microns
TC	6.00	minutes	RAINFALL STATION	69	

Rainfall Intensity ¹ (in/hr)	Percent Rainfall Volume ¹	Hydraulic Loading Rate (gpm/ft ²)	Removal Efficiency (%)	Incremental Removal (%)
0.02	10.2%	0.61	100.0	10.2
0.04	9.6%	1.22	100.0	9.6
0.06	9.4%	1.83	100.0	9.4
0.08	7.7%	2.44	100.0	7.7
0.10	8.6%	3.05	100.0	8.6
0.12	6.3%	3.66	100.0	6.3
0.14	4.7%	4.28	100.0	4.7
0.16	4.6%	4.89	100.0	4.6
0.18	3.5%	5.50	100.0	3.5
0.20	4.3%	6.11	100.0	4.3
0.25	8.0%	7.63	100.0	8.0
0.30	5.6%	9.16	100.0	5.6
0.35	4.4%	10.69	100.0	4.4
0.40	2.5%	12.22	100.0	2.5
0.45	2.5%	13.74	99.0	2.5
0.50	1.4%	15.27	97.5	1.3
0.75	5.0%	22.90	90.4	4.6
1.00	1.0%	30.54	83.2	0.8
1.50	0.0%	45.81	68.8	0.0
2.00	0.0%	61.08	54.5	0.0
3.00	0.5%	76.08	33.5	0.2

99.0

Removal Efficiency Adjustment ² =	6.5%
Predicted % Annual Rainfall Treated =	93.5%
Predicted Net Annual Load Removal Efficiency =	92.5%

1 - Based on 10 years of hourly precipitation data from NCDC Station 770, Boston WSFO AP, Suffolk County, MA

2 - Reduction due to use of 60-minute data for a site that has a time of concentration less than 30-minutes.

Estimated Net Annual Solids Load Reduction
Based on the Rational Rainfall Method



ANDOVER TOWN YARD
ANDOVER, MA
WQU 1



AREA 1.80 acres CASCADE MODEL CS-5
WEIGHTED C 0.95 PARTICLE SIZE 110 microns
TC 6.00 minutes RAINFALL STATION 69

Rainfall Intensity ¹ (in/hr)	Percent Rainfall Volume ¹	Hydraulic Loading Rate (gpm/ft ²)	Removal Efficiency (%)	Incremental Removal (%)
0.02	10.2%	0.78	100.0	10.2
0.04	9.6%	1.56	100.0	9.6
0.06	9.4%	2.35	100.0	9.4
0.08	7.7%	3.13	100.0	7.7
0.10	8.6%	3.91	100.0	8.6
0.12	6.3%	4.69	100.0	6.3
0.14	4.7%	5.47	100.0	4.7
0.16	4.6%	6.25	100.0	4.6
0.18	3.5%	7.04	100.0	3.5
0.20	4.3%	7.82	100.0	4.3
0.25	8.0%	9.77	100.0	8.0
0.30	5.6%	11.73	100.0	5.6
0.35	4.4%	13.68	99.0	4.3
0.40	2.5%	15.64	97.2	2.5
0.45	2.5%	17.59	95.4	2.4
0.50	1.4%	19.54	93.5	1.3
0.75	5.0%	29.32	84.3	4.3
1.00	1.0%	39.09	75.2	0.8
1.50	0.0%	58.63	56.8	0.0
2.00	0.0%	78.18	38.4	0.0
3.00	0.5%	80.01	25.0	0.1

98.3

Removal Efficiency Adjustment² = 6.5%
 Predicted % Annual Rainfall Treated = 93.4%
 Predicted Net Annual Load Removal Efficiency = 91.8%

1 - Based on 10 years of hourly precipitation data from NCDC Station 770, Boston WSFO AP, Suffolk County, MA

2 - Reduction due to use of 60-minute data for a site that has a time of concentration less than 30-minutes.



Jellyfish Filter Design Calculation

Contech Engineered Solutions, LLC Engineer:
Date Prepared:

DRA
1/24/2024

Site Information

Project Name	Andover Town Yard
Project City	Andover
Project State	MA
Site Designation	JF 1
Total Drainage Area, Ad	2.30 ac
Post Development Impervious Area, Ai	1.80 ac
Pervious Area, Ap	0.50 ac
% Impervious	78%
Runoff Coefficient, Rc	0.75

Mass Loading Calculations

Mean Annual Rainfall, P	48 in
Agency Required % Removal	80%
Percent Runoff Capture	90%
Mean Annual Runoff, Vt	272,076 ft ³
Event Mean Concentration of Pollutant, EMC	70 mg/l
Annual Mass Load, M total	1,188 lbs

Filter System

Filtration Brand	Jellyfish
Cartridge Length	54 in

Jellyfish Sizing

Mass to be Captured by System	951 lbs
Water Quality Flow	2.18 cfs

Method to Use

FLOW BASED

Summary		
	Treatment Flow Rate	2.23 cfs
Flow	Required Size	JFPD0808-11-3
	Mass Capture provided	1,564 lbs

Weighted Runoff Coefficients "C" for Rational Method

THE MORIN-CAMERON GROUP, INC.

66 Elm Street
 Danvers, MA 01923
 P: (978) 777-8586
 F: (978) 774-3488
 W: www.morincameron.com

C' - Coefficients
 Pervious Soil 0.35
 Impervious 0.9

Description of Area CB-1	Area (acres)	Runoff Coefficient	A x C
Pervious	0.050	0.35	0.02
Impervious	0.130	0.90	0.12
Totals =	0.180		0.13

Weighted Runoff Coefficient = $S(AxC) / SA = 0.75$

Description of Area CB-2	Area (acres)	Runoff Coefficient	A x C
Pervious	0.340	0.35	0.12
Impervious	0.600	0.90	0.54
Totals =	0.940		0.66

Weighted Runoff Coefficient = $S(AxC) / SA = 0.70$

Description of Area CB-3	Area (acres)	Runoff Coefficient	A x C
Pervious	0.260	0.35	0.09
Impervious	0.400	0.90	0.36
Totals =	0.660		0.45

Weighted Runoff Coefficient = $S(AxC) / SA = 0.68$

Description of Area CB-4	Area (acres)	Runoff Coefficient	A x C
Pervious	0.046	0.35	0.02
Impervious	0.190	0.90	0.17
Totals =	0.236		0.19

Weighted Runoff Coefficient = $S(AxC) / SA = 0.79$

Description of Area CB-5	Area (acres)	Runoff Coefficient	A x C
Pervious	0.013	0.35	0.00
Impervious	0.072	0.90	0.06
Totals =	0.085		0.07

Weighted Runoff Coefficient = $S(AxC) / SA = 0.82$

Description of Area CB-6	Area (acres)	Runoff Coefficient	A x C
Pervious	0.010	0.35	0.00
Impervious	0.049	0.90	0.04
Totals =	0.059		0.05

Weighted Runoff Coefficient = $S(AxC) / SA = 0.81$

Description of Area CB-7	Area (acres)	Runoff Coefficient	A x C
Pervious	0.007	0.35	0.00
Impervious	0.050	0.90	0.05
Totals =	0.057		0.05

Weighted Runoff Coefficient = $S(AxC) / SA = 0.83$

Description of Area CB-8	Area (acres)	Runoff Coefficient	A x C
Pervious	0.006	0.35	0.00
Impervious	0.047	0.90	0.04
Totals =	0.053		0.04

Weighted Runoff Coefficient = $S(AxC) / SA = 0.84$

Description of Area CB-9	Area (acres)	Runoff Coefficient	A x C
Pervious	0.090	0.35	0.03
Impervious	0.070	0.90	0.06
Totals =	0.160		0.09

Weighted Runoff Coefficient = $S(AxC) / SA = 0.59$

Description of Area CB-10	Area (acres)	Runoff Coefficient	A x C
Pervious	0.150	0.35	0.05
Impervious	0.430	0.90	0.39
Totals =	0.580		0.44

Weighted Runoff Coefficient = $S(AxC) / SA = 0.76$

Description of Area	Area (acres)	Runoff Coefficient	A x C
CB-11			
Pervious	0.050	0.35	0.02
Impervious	0.015	0.90	0.01
Totals =	0.065		0.03

Weighted Runoff Coefficient = $S(Ax C) / SA = 0.48$

Description of Area	Area (acres)	Runoff Coefficient	A x C
CB-13			
Pervious	0.000	0.35	0.00
Impervious	0.060	0.90	0.05
Totals =	0.060		0.05

Weighted Runoff Coefficient = $S(Ax C) / SA = 0.90$

Description of Area	Area (acres)	Runoff Coefficient	A x C
CB-15			
Pervious	0.170	0.35	0.06
Impervious	0.420	0.90	0.38
Totals =	0.590		0.44

Weighted Runoff Coefficient = $S(Ax C) / SA = 0.74$

Description of Area	Area (acres)	Runoff Coefficient	A x C
AD-2			
Pervious	0.140	0.35	0.05
Impervious	0.130	0.90	0.12
Totals =	0.270		0.17

Weighted Runoff Coefficient = $S(Ax C) / SA = 0.61$

Description of Area	Area (acres)	Runoff Coefficient	A x C
AD-4			
Pervious	0.140	0.35	0.05
Impervious	0.056	0.90	0.05
Totals =	0.196		0.10

Weighted Runoff Coefficient = $S(Ax C) / SA = 0.51$

Description of Area	Area (acres)	Runoff Coefficient	A x C
R-2			
Pervious	0.000	0.35	0.00
Impervious	0.548	0.90	0.49
Totals =	0.548		0.49

Weighted Runoff Coefficient = $S(Ax C) / SA = 0.90$

Description of Area	Area (acres)	Runoff Coefficient	A x C
R-4			
Pervious	0.000	0.35	0.00
Impervious	0.499	0.90	0.45
Totals =	0.499		0.45

Weighted Runoff Coefficient = $S(Ax C) / SA = 0.90$

Description of Area	Area (acres)	Runoff Coefficient	A x C
CB-12			
Pervious	0.006	0.35	0.00
Impervious	0.075	0.90	0.07
Totals =	0.081		0.07

Weighted Runoff Coefficient = $S(Ax C) / SA = 0.86$

Description of Area	Area (acres)	Runoff Coefficient	A x C
CB-14			
Pervious	0.120	0.35	0.04
Impervious	0.120	0.90	0.11
Totals =	0.240		0.15

Weighted Runoff Coefficient = $S(Ax C) / SA = 0.63$

Description of Area	Area (acres)	Runoff Coefficient	A x C
AD-1			
Pervious	0.100	0.35	0.04
Impervious	0.130	0.90	0.12
Totals =	0.230		0.15

Weighted Runoff Coefficient = $S(Ax C) / SA = 0.66$

Description of Area	Area (acres)	Runoff Coefficient	A x C
AD-3			
Pervious	0.180	0.35	0.06
Impervious	0.072	0.90	0.06
Totals =	0.252		0.13

Weighted Runoff Coefficient = $S(Ax C) / SA = 0.51$

Description of Area	Area (acres)	Runoff Coefficient	A x C
R-1			
Pervious	0.000	0.35	0.00
Impervious	0.182	0.90	0.16
Totals =	0.182		0.16

Weighted Runoff Coefficient = $S(Ax C) / SA = 0.90$

Description of Area	Area (acres)	Runoff Coefficient	A x C
R-3			
Pervious	0.000	0.35	0.00
Impervious	0.360	0.90	0.32
Totals =	0.360		0.32

Weighted Runoff Coefficient = $S(Ax C) / SA = 0.90$

Description of Area	Area (acres)	Runoff Coefficient	A x C
R-5			
Pervious	0.000	0.35	0.00
Impervious	0.063	0.90	0.06
Totals =	0.063		0.06

Weighted Runoff Coefficient = $S(Ax C) / SA = 0.90$

VERIFY PIP+A12:X67E CAPACITY-25 YEAR STORM

Pipe Sizing Calculation Spreadsheet:

THE MORIN-CAMERON GROUP, INC.

66 Elm Street
 Danvers, MA 01923
 P: (978) 777-8586
 F: (978) 774-3488
 W: www.morincameron.com

Name: Andover Town Yard
 Location: 11 Lewis Street
 Andover, Massachusetts
 County: Essex County
 Owner: Town of Andover &
 Buxton Redevelopment

Proj. No.: 4145
 Date: 11/15/2023
 Revised: 2/20/2024
 Computed by: Leticia Oliveira
 Checked by: Scott P, Cameron, P.E.

Design Parameters:
IDF Curve
25 Year Storm
 k_s= **0.2**

DESCRIPTION	LOCATION		AREA (AC.)	C	C x A	SUM C x A	FLOW TIME (MIN)		i*	DESIGN					CAPACITY		PIPE PROFILE				
	FROM	TO					PIPE	CONC. TIME		Q cfs	V fps	n	PIPE SIZE	SLOPE	Q full ft ³ /s	V full ft/s	LENGTH ft	FALL ft	RIM	INV UPPER	INV LOWER
CB-14	CB-14	DMH-12	0.24	0.63	0.15	0.15	0.08	6.0	5.7	0.9	4.1	0.012	12	0.020	5.5	6.9	20	0.40	109.90	104.58	104.18
CB-15	CB-15	DMH-12	0.59	0.74	0.44	0.44	0.06	6.0	5.7	2.5	5.8	0.012	12	0.020	5.5	6.9	20	0.40	109.90	104.58	104.18
R-1	R-1	DMH-12	0.18	0.90	0.16	0.16	0.10	6.0	5.7	0.9	4.2	0.012	12	0.020	5.5	6.9	26	0.52	109.90	99.02	98.50
DMH-12	DMH-12	DMH-1	-	-	-	0.75	0.58	6.1	5.7	4.3	6.1	0.012	12	0.015	4.7	6.0	215	3.23	108.20	98.04	94.81
CB-1	CB-1	DMH-1	0.18	0.75	0.13	0.13	0.12	6.0	5.7	0.8	4.0	0.012	12	0.020	5.5	6.9	30	0.60	99.90	96.40	95.80
CB-2	CB-2	DMH-1	0.94	0.70	0.66	0.66	0.08	6.0	5.7	3.8	6.5	0.012	12	0.020	5.5	6.9	30	0.60	99.90	96.40	95.80
DMH-1	DMH-1	DMH-2	-	-	-	1.55	0.15	6.7	5.6	8.6	8.1	0.012	15	0.020	9.9	8.1	74	1.48	99.20	94.60	93.14
DMH-2	DMH-2	DMH-4	-	-	-	3.40	0.08	6.8	5.5	18.9	11.6	0.012	18	0.030	19.7	11.2	54	1.62	98.20	90.20	88.58
OCS-1	OCS-1	DMH-4	-	-	-	-	0.10	6.0	5.7	5.9	7.1	0.012	15	0.020	9.9	8.1	41	0.82	98.60	91.35	90.50
DMH-4	DMH-4	DMH-5	-	-	-	-	0.03	6.9	5.5	24.8	15.2	0.012	18	0.052	25.9	14.6	29	1.50	88.80	83.00	81.50
CB-11	CB-11	DMH-11	0.07	0.48	0.03	0.03	0.52	6.0	5.7	0.2	1.5	0.012	12	0.006	3.0	3.8	48	0.29	97.90	95.10	94.81
CB-10	CB-10	DMH-11	0.58	0.76	0.44	0.44	0.05	6.0	5.7	2.5	5.8	0.012	12	0.020	5.5	6.9	19	0.38	98.50	95.70	95.32
DMH-11	DMH-11	DMH-10	-	-	-	0.47	0.28	6.5	5.6	2.6	3.9	0.012	12	0.006	3.0	3.8	66	0.40	99.10	94.75	94.35
R-4	R-4	DMH-14	0.50	0.90	0.45	0.45	0.05	6.0	5.7	2.6	6.3	0.012	12	0.025	6.1	7.8	20	0.50	112.20	108.50	108.00
DMH-14	DMH-14	DMH-13	-	-	-	0.45	0.58	6.1	5.7	2.6	5.7	0.012	12	0.020	5.4	6.9	198	3.90	112.10	99.40	95.50
AD-4	AD-4	DMH-13	0.20	0.51	0.10	0.10	0.14	6.0	5.7	0.6	3.3	0.012	12	0.015	4.7	6.0	28	0.42	100.40	96.20	95.78
AD-3	AD-3	DMH-13	0.25	0.51	0.13	0.13	0.04	6.0	5.7	0.7	3.9	0.012	12	0.020	5.5	6.9	9	0.18	100.30	96.10	95.92
R-5	R-5	DMH-13	0.06	0.90	0.06	0.06	0.37	6.0	5.7	0.3	2.7	0.012	12	0.017	5.0	6.3	60	1.00	101.00	96.50	95.50
DMH-13	DMH-13	DMH-10	-	-	-	0.73	0.35	6.8	5.6	4.1	5.0	0.012	15	0.010	7.0	5.7	105	1.05	100.40	95.60	94.55
DMH-10	DMH-10	DMH-9	-	-	-	0.73	0.53	7.2	5.5	4.0	4.2	0.012	15	0.006	5.4	4.4	132	0.78	99.40	94.25	93.47
CB-9	CB-9	DMH-9	0.16	0.59	0.09	0.09	0.03	6.0	5.7	0.5	3.4	0.012	12	0.020	5.5	6.9	7	0.14	99.25	95.00	94.86
DMH-9	DMH-9	DMH-8	-	-	-	0.83	0.27	7.7	5.4	4.4	4.4	0.012	15	0.006	5.5	4.5	71	0.44	99.40	93.37	92.93
CB-8	CB-8	DMH-8	0.05	0.84	0.04	0.04	0.05	6.0	5.7	0.3	2.5	0.012	12	0.020	5.5	6.9	7	0.14	99.25	95.00	94.86

Pipe Sizing Calculation Spreadsheet:

THE MORIN-CAMERON GROUP, INC.

66 Elm Street
 Danvers, MA 01923
 P: (978) 777-8586
 F: (978) 774-3488
 W: www.morincameron.com

Name: Andover Town Yard
Location: 11 Lewis Street
 Andover, Massachusetts
County: Essex County
Owner: Town of Andover &
 Buxton Redevelopment

Proj. No.: 4145
Date: 11/15/2023
Revised: 2/20/2024
Computed by: Leticia Oliveira
Checked by: Scott P, Cameron, P.E.

Design Parameters:
IDF Curve
25 Year Storm
 k_e= **0.2**

DESCRIPTION	LOCATION		AREA (AC.)	C	C x A	SUM C x A	FLOW TIME (MIN)		i*	DESIGN					CAPACITY		PIPE PROFILE				
	FROM	TO					PIPE	CONC. TIME		Q cfs	V fps	n	PIPE SIZE	SLOPE	Q full ft^3/s	V full ft/s	LENGTH ft	FALL ft	RIM	INV UPPER	INV LOWER
DMH-8	DMH-8	DMH-7	-	-	-	0.87	0.27	8.0	5.3	4.6	4.4	0.012	15	0.006	5.4	4.4	71	0.43	99.40	92.83	92.40
CB-7	CB-7	DMH-7	0.06	0.83	0.05	0.05	0.05	6.0	5.7	0.3	2.5	0.012	12	0.020	5.5	6.9	7	0.14	99.25	95.00	94.86
R3	R3	DMH-7	0.36	0.90	0.32	0.32	0.07	6.0	5.7	1.9	3.7	0.012	12	0.008	3.3	4.3	16	0.12	100.00	95.00	94.88
DMH-7	DMH-7	DMH-6	-	-	-	1.24	0.18	8.2	5.3	6.5	6.7	0.012	15	0.015	8.6	7.0	71	1.07	99.40	92.94	91.87
CB-6	CB-6	DMH-6	0.06	0.81	0.05	0.05	0.04	6.0	5.7	0.3	2.8	0.012	12	0.020	5.5	6.9	7	0.14	99.25	95.00	94.86
DMH-6	DMH-6	WQU-1	-	-	-	1.29	0.23	8.4	5.2	6.7	4.8	0.012	18	0.006	8.8	5.0	65	0.39	99.40	91.77	91.38
CB-5	CB-5	WQU-1	0.09	0.82	0.07	0.07	0.04	6.0	5.7	0.4	3.1	0.012	12	0.020	5.5	6.9	7	0.14	99.25	95.00	94.86
WQU-1	WQU-1	JF1	-	-	-	1.36	0.03	8.6	5.2	7.0	4.9	0.012	18	0.006	8.8	5.0	10	0.06	99.40	91.28	91.22
JF-1	JF-1	DMH-2	0.00	0.00	-	1.36	0.22	6.0	5.7	7.8	5.1	0.012	18	0.006	8.9	5.0	66	0.40	99.50	90.72	90.32
R2	R2	DMH-2	0.55	0.90	0.49	0.49	0.25	6.0	5.7	2.8	5.1	0.012	12	0.013	4.4	5.6	76	1.00	100.00	95.00	94.00
CB-3	CB-3	DMH-3	0.66	0.68	0.45	0.45	0.02	6.0	5.7	2.6	5.8	0.012	12	0.020	5.5	6.9	7	0.14	97.50	93.30	93.16
CB-4	CB-4	DMH-3	0.24	0.79	0.19	0.19	0.07	6.0	5.7	1.1	4.4	0.012	12	0.020	5.5	6.9	20	0.40	97.50	93.30	92.90
AD-1	AD-1	DMH-3	0.23	0.66	0.15	0.15	0.18	6.0	5.7	0.9	3.7	0.012	12	0.015	4.7	5.9	41	0.60	97.90	93.70	93.10
DMH-3	DMH-3	WQU-2	-	-	-	0.79	0.14	6.2	5.7	4.5	6.3	0.012	12	0.015	4.7	6.0	54	0.81	97.80	92.80	92.10
AD-2	AD-2	I.SYSTEM	0.27	0.61	0.17	0.17	0.07	6.0	5.7	1.0	4.2	0.012	12	0.020	5.5	6.9	17	0.34	95.90	91.69	91.35
WQU-2	WQU-2	I.SYSTEM	-	-	-	0.96	0.03	6.3	5.7	5.4	7.9	0.012	12	0.025	6.1	7.8	16	0.40	98.70	91.75	91.35
I.SYSTEM	I.SYSTEM	OCS-1	-	-	-	-	0.96	6.3	5.7	5.9	5.5	0.012	18	0.010	11.4	6.4	5	0.05	99.00	91.35	91.30

**APPENDIX E:
CONSTRUCTION PHASE
BEST MANAGEMENT PRACTICES**

Construction Phase Best Management Practices (BMP's)

Erosion and Sedimentation will be controlled at the site by utilizing Structural Practices, Stabilization Practices, and Dust Control. These practices correspond with plans entitled "Site Development Plans - 2-4 Buxton Court, 7-9 & 11 Lewis Street, 35 Pearson Street & 122 North Main Street - Andover, Massachusetts" prepared by The Morin-Cameron Group, Inc. dated November 15, 2023 and revised on February 20, 2024.

Responsible Party Contact Information:

Stormwater Management System Owner:

Andover Town Yard, LLC
231 Sutton Street, Suite 1B
North Andover, 01845
P: (978) 687-6200

Andover Department of Public Works:

5 Campanelli Drive
Andover, MA 01810
P: (978) 623-8700

Andover Planning Board:

Town Hall
36 Bartlet Street
Andover, MA 01810
P: (978) 623-8230

Site Design Engineer Information:

The Morin-Cameron Group, Inc.
66 Elm Street
Danvers, MA 01923
Phone: (978) 777-8586

Owner Signature:

Structural Practices:

- 1) **Straw Wattle/Mulch Sock** – Straw Wattle and mulch sock fence shall be installed in accordance with the approved plans where high rates of stormwater runoff are anticipated.
 - a) Installation Schedule: Prior to Start of land disturbance
 - a) Maintenance and Inspection: The site supervisor shall inspect the barrier at least once per week or after a major storm (3.15 inches of rainfall within a twenty-four-hour period). event and shall repair any damaged or affected areas of the barrier at the time they are noted. Remove sediment deposits promptly after storm events to provide adequate storage volume for the next rain and to reduce pressure on the barrier. Sediment will be removed from in front of the barrier when it becomes about 4" deep at the barrier. Take care to avoid undermining the barrier during cleanout.
- 2) **Inlet Protection** – Inlet Protection will be utilized around the catch basin grates in the street layout along the frontage of the property. The inlet protection will allow the storm drain inlets to be used before final stabilization. This structural practice will allow early use of the drainage system. Siltsack or equivalent will be utilized for the inlet protection. Siltsack is manufactured by ACF Environmental. The telephone number is 800-448-3636. Regular flow siltsack will be utilized, and if it does not allow enough storm water flow, hi-flow siltsack will be utilized.

Silt Sack (or equivalent) Inlet Protection Inspection/Maintenance Requirements *

- a) The silt sack trapping devices and the catch basins should be inspected after every rain storm and repairs made as necessary.
- b) Sediment should be removed from the silt sack after the sediment has reached a maximum depth of one-half the depth of the trap.
- c) Sediment should be disposed of in a suitable area and protected from erosion by either structural or vegetative means. Sediment material removed shall be disposed of in accordance with all applicable local, state, and federal regulations.
- d) The silt sack must be replaced if it is ripped or torn in any way.
- e) Temporary traps should be removed and the area repaired as soon as the contributing drainage area to the inlet has been completely stabilized.

- 3) Sediment Track-Out:** Stabilized Construction Exit: Prior to the commencement of site work, crushed stone anti-tracking pads will be installed at the entrance to the site. This will prevent trucks from tracking material onto the road from the construction site. If, at any point during the project, the tracking pad becomes ineffective due to accumulation of soil, the crushed stone shall be replaced. Details for construction of the stabilized entrance can be found in the details sheet that is part of the comprehensive permit plan set associated with the project. The site supervisor will inspect the tracking pads weekly to ensure that they are properly limiting the tracking of soil onto the road. If tracking onto the roadway is noted, it shall be removed immediately via by hand or a mechanical street sweeper.

Stabilization Practices:

Stabilization measures shall be implemented as soon as practicable in portions of the site where construction activities have temporarily or permanently ceased, but in no case more than 14 days after the construction activity in that portion of the site has temporarily or permanently ceased, with the following exceptions.

- Where the initiation of stabilization measures by the 14th day after construction activity temporary or permanently cease is precluded by snow cover, stabilization measures shall be initiated as soon as practicable.
 - Where construction activity will resume on a portion of the site within 21 days from when activities ceased, (e.g. the total time period that construction activity is temporarily ceased is less than 21 days) then stabilization measures do not have to be initiated on that portion of the site by the 14th day after construction activity temporarily ceased.
- 1) **Temporary Seeding** – Temporary seeding will allow a short-term vegetative cover on disturbed site areas that may be in danger of erosion. Temporary seeding will be done at stock piles and disturbed portions of the site where construction activity will temporarily cease for at least 21 days. The temporary seeding will stabilize cleared and unvegetated areas that will not be brought into final grade for several weeks or months.

Temporary Seeding Planting Procedures *

- a) Planting should preferably be done between April 1st and June 30th, and September 1st through September 31st. If planting is done in the months of July and August, irrigation may be required. If planting is done between October 1st and March 31st, mulching should be applied immediately after planting.
- b) Before seeding, install structural practice controls. Utilize Amoco supergro or equivalent.
- c) Select the appropriate seed species for temporary cover from the following table.

Species	Seeding Rate (lbs./1,000 sq.)	Seeding Rate (lbs./acre)	Recommended Seeding Dates	Seed Cover required
Annual Ryegrass	1	40	April 1 st to June 1 st August 15 th to Sept. 15 th	¼ inch
Foxtail Millet	0.7	30	May 1 st to June 30 th	½ to ¾ inch
Oats	2	80	April 1 st to July 1 st August 15 th to Sept. 15 th	1 to 1-½ inch
Winter Rye	3	120	August 15 th to Oct. 15 th	1 to 1-½ inch

Apply the seed uniformly by hydroseeding, broadcasting, or by hand.

- d) Use effective mulch, such as clean grain straw; tacked and/or tied with netting to protect seedbed and encourage plant growth.

Temporary Seeding Inspection/Maintenance *

- a) Inspect within 6 weeks of planting to see if stands are adequate. Check for damage within 24 hours of the end to a heavy rainfall, defined as a 2-year storm event (i.e., 3.15 inches of rainfall within a twenty-four-hour period). Stands should be uniform and dense. Reseed and mulch damaged and sparse areas immediately. Tack or tie down mulch as necessary.
- b) Seeds should be supplied with adequate moisture. Furnish water as needed, especially in abnormally hot or dry weather. Water application rates should be controlled to prevent runoff.
- 2) **Geotextiles** - Geotextiles such as jute netting will be used in combination with other practices such as mulching to stabilize slopes. The following geotextile materials or equivalent are to be utilized for structural and nonstructural controls as shown in the following table.

Practice	Manufacturer	Product	Remarks
Sediment Fence	Amoco	Woven polypropylene 1198 or equivalent	0.425 mm opening
Construction Entrance	Amoco	Woven polypropylene 2002 or equivalent	0.300 mm opening
Outlet Protection	Amoco	Nonwoven polypropylene 4551 or equivalent	0.150 mm opening
Erosion Control (slope stability)	Amoco	Supergro or equivalent	Erosion control revegetation mix, open polypropylene fiber on degradable polypropylene net scrim

Amoco may be reached at (800) 445-7732

Geotextile Installation

- a) Netting and matting require firm, continuous contact between the materials and the soil. If there is no contact, the material will not hold the soil and erosion will occur underneath the material.

Geotextile Inspection/Maintenance *

- a) In the field, regular inspections should be made to check for cracks, tears, or breaches in the fabric. The appropriate repairs should be made.
- 3) **Mulching and Netting** – Mulching will provide immediate protection to exposed soils during the period of short construction delays, or over winter months through the application of plant residues, or other suitable materials, to exposed soil areas. In areas, which have been seeded either for temporary or permanent cover, mulching should immediately follow seeding. On steep slopes, mulch must be supplemented with netting. The preferred mulching material is straw.

Mulch (Hay or Straw) Materials and Installation

- a) Straw has been found to be one of the most effective organic mulch materials. The specifications for straw are described below, but other material may be appropriate. The straw should be air-dried; free of undesirable seeds & coarse materials. The application rate per 1,000 sq. is 90-100 lbs. (2-3 bales) and the application rate per acre is 2 tons (100-120 bales). The application should cover about 90% of the surface. The use of straw mulch is appropriate where mulch is maintained for more than three months. Straw mulch is subject to wind blowing unless anchored, is the most commonly used mulching material, and has the best microenvironment for germinating seeds.

Mulch Maintenance *

- a) Inspect after rainstorms to check for movement of mulch or erosion. If washout, breakage, or erosion occurs, repair surface, reseed, remulch, and install new netting.
 - b) Straw or grass mulches that blow or wash away should be repaired promptly.
 - c) If plastic netting is used to anchor mulch, care should be taken during initial mowing to keep the mower height high. Otherwise, the netting can wrap up on the mower blade shafts. After a period of time, the netting degrades and becomes less of a problem.
 - d) Continue inspections until vegetation is well established.
- 4) **Land Grading** – Grading on fill slopes, cut slopes, and stockpile areas will be done with full siltation controls in place.

Land Grading Design/Installation Requirements

- a) Areas to be graded should be cleared and grubbed of all timber, logs, brush, rubbish, and vegetated matter that will interfere with the grading operation. Topsoil should be stripped and stockpiled for use on critical disturbed areas for establishment of vegetation. Cut slopes to be topsoiled should be thoroughly scarified to a minimum depth of 3-inches prior to placement of topsoil.
- b) Fill materials should be generally free of brush, rubbish, rocks, and stumps. Frozen materials or soft and easily compressible materials should not be used in fills intended to support buildings, parking lots, roads, conduits, or other structures.
- c) Earth fill intended to support structural measures should be compacted to a minimum of 90 percent of Standard Proctor Test density with proper moisture control, or as otherwise specified by the engineer responsible for the design. Compaction of other fills should be to the density required to control sloughing, erosion or excessive moisture content. Maximum thickness of fill layers prior to compaction should not exceed 9 inches.
- d) The uppermost one foot of fill slopes should be compacted to at least 85 percent of the maximum unit weight (based on the modified AASHTO compaction test). This is usually accomplished by running heavy equipment over the fill.
- e) Fill should consist of material from borrow areas and excess cut will be stockpiled on site. All disturbed areas should be free draining, left with a neat and finished appearance, and should be protected from erosion.

Land Grading Stabilization Inspection/Maintenance *

- a) All slopes should be checked periodically to see that vegetation is in good condition. Any rills or damage from erosion and animal burrowing should be repaired immediately to avoid further damage.
 - b) If seeps develop on the slopes, the area should be evaluated to determine if the seep will cause an unstable condition. Subsurface drains or a gravel mulch may be required to solve seep problems.
 - c) Areas requiring revegetation should be repaired immediately. Control undesirable vegetation such as weeds and woody growth to avoid bank stability problems in the future.
- 5) **Topsoiling *** – Topsoiling will help establish vegetation on all disturbed areas throughout the site during the seeding process. The soil texture of the topsoil to be used will be a sandy loam to a silt loam texture with 15% to 20% organic content.

Topsoiling Placement

- a) Topsoil should not be placed while in a frozen or muddy condition, when the subgrade is excessively wet, or when conditions exist that may otherwise be detrimental to proper grading or proposed seeding.

- b) Do not place topsoil on slopes steeper than 2.5:1, as it will tend to erode.
 - c) If topsoil and subsoil are not properly bonded, water will not infiltrate the soil profile evenly and it will be difficult to establish vegetation. The best method is to actually work the topsoil into the layer below for a depth of at least 6 inches.
- 6) **Permanent Seeding** – Permanent Seeding should be done immediately after the final design grades are achieved. Native species of plants should be used to establish perennial vegetative cover on disturbed areas. The revegetation should be done early enough in the fall so that a good cover is established before cold weather comes and growth stops until the spring. A good cover is defined as vegetation covering 75 percent or more of the ground surface.

Permanent Seeding Seedbed Preparation

- a) In infertile or coarse-textured subsoil, it is best to stockpile topsoil and re-spread it over the finished slope at a minimum 2 to 6-inch depth and roll it to provide a firm seedbed. The topsoil must have a sandy loam to silt loam texture with 15% to 20% organic content. If construction fill operations have left soil exposed with a loose, rough, or irregular surface, smooth with blade and roll.
- b) Loosen the soil to a depth of 3-5 inches with suitable agricultural or construction equipment.
- c) Areas not to receive topsoil shall be treated to firm the seedbed after incorporation of the lime and fertilizer so that it is depressed no more than ½ - 1 inch when stepped on with a shoe. Areas to receive topsoil shall not be firmed until after topsoiling and lime and fertilizer is applied and incorporated, at which time it shall be treated to firm the seedbed as described above.

Permanent Seeding Grass Selection/Application

- a) Select an appropriate cool or warm season grass based on site conditions and seeding date. Apply the seed uniformly by hydro-seeding, broadcasting, or by hand. Uniform seed distribution is essential. On steep slopes, hydroseeding may be the most effective seeding method. Surface roughening is particularly important when preparing slopes for hydroseeding.
- b) Lime and fertilize. Organic fertilizer shall be utilized in areas within the 100-foot buffer zone to a wetland resource area.
- c) Mulch the seedings with straw applied at the rate of ½ tons per acre. Anchor the mulch with erosion control netting or fabric on sloping areas. Amoco supergro or equivalent should be utilized.

Permanent Seeding Inspection/Maintenance *

- a) Frequently inspect seeded areas for failure and make necessary repairs and reseed immediately. Conduct or follow-up survey after one year and replace failed plants where necessary.
- b) If vegetative cover is inadequate to prevent rill erosion, overseed and fertilize in accordance with soil test results.
- c) If a stand has less than 40% cover, reevaluate choice of plant materials and quantities of lime and fertilizer. Re-establish the stand following seedbed preparation and seeding recommendations, omitting lime and fertilizer in the absence of soil test results. If the season prevents resowing, mulch or jute netting is an effective temporary cover.
- d) Seeded areas should be fertilized during the second growing season. Lime and fertilize thereafter at periodic intervals, as needed. Organic fertilizer shall be utilized in areas within the 100-foot buffer zone to a wetland resource area.

Dust Control:

Dust control will be utilized throughout the entire construction process of the site. For example, keeping disturbed surfaces moist during windy periods will be an effective control measure, especially for construction access roads. The use of dust control will prevent the movement of soil to offsite areas. However, care must be taken to not create runoff from excessive use of water to control dust. The following are methods of Dust Control that may be used on-site:

- Vegetative Cover – The most practical method for disturbed areas not subject to traffic.
- Calcium Chloride – Calcium chloride may be applied by mechanical spreader as loose, dry granules or flakes at a rate that keeps the surface moist but not so high as to cause water pollution or plant damage.
- Sprinkling – The site may be sprinkled until the surface is wet. Sprinkling will be effective for dust control on haul roads and other traffic routes.
- Stone – Stone will be used to stabilize construction roads and will provide dust control.

The general contractor shall employ an on-site water vehicle for the control of dust as necessary.

Non-Stormwater Discharges:

The construction de-watering and all non-stormwater discharges will be directed into a sediment dirt bag (or equivalent inlet protection) or a sediment basin. Sediment material removed shall be disposed of in accordance with all applicable local, state, and federal regulations.

The developer and site general contractor will comply with the E.P.A.'s Final General Permit for Construction De-watering Discharges, (N.P.D.E.S., Section 402 and 40 C.F.R. 122.26(b) (14) (x).

Inspection/Maintenance:

Operator personnel must inspect the construction site at least once every 14 calendar days and within 24 hours of a storm event of ½-inch or greater. The applicant shall be responsible to secure the services of a design professional or similar professional (inspector) on an on-going basis throughout all phases of the project. Refer to the Inspection/Maintenance Requirements presented earlier in the "Structural and Stabilization Practices." The inspector should review the erosion and sediment controls with respect to the following:

- Whether or not the measure was installed/performed correctly.
- Whether or not there has been damage to the measure since it was installed or performed.
- What should be done to correct any problems with the measure.

The inspector should complete a Stormwater Management Construction Phase BMP Inspection Schedule and Evaluation Checklist for documenting the findings and should request the required maintenance or repair for the pollution prevention measures when the inspector finds that it is necessary for the measure to be effective. The inspector should notify the appropriate person to make the required changes.

It is essential that the inspector document the inspection of the pollution prevention measures. These records will be used to request maintenance and repair and to prove that the inspection and maintenance were performed. The forms list each of the measures to be inspected on the site, the inspector's name, the date of the inspection, the condition of the measure/area inspected, maintenance or repair performed and any changes which should be made to the Operation and Maintenance Plan to control or eliminate unforeseen pollution of storm water.

**APPENDIX F:
LONG TERM BEST MANAGEMENT
PRACTICES O&M PLAN**

Long Term Stormwater Best Management Practices
Operation and Maintenance Plan

for

Site Development Plans “Andover Town Yard”
Andover, Massachusetts

Issued November 15, 2023, Revised February 20, 2024

The following operation and maintenance plan has been provided to satisfy the requirements of Standard 9 of the Mass DEP Stormwater Management Handbook associated with development of the site and associated infrastructure. The success of the Stormwater Management Plan depends on the proper implementation, operation and maintenance of several management components. The following procedures shall be implemented to ensure success of the Stormwater Management Plan:

1. The contractor shall comply with the details of construction of the site as shown on the approved plans.
2. The catch basins, subsurface detention and recharge galleys, pocket wetland and CDS water quality units shall be inspected and maintained as indicated below.
3. Effective erosion control measurers during and after construction shall be maintained until a stable turf is established on all altered areas.
4. A Stormwater Management Maintenance Log is included at the end of this Appendix.

Basic Information

Stormwater Management System Owner:

Andover Town Yard, LLC
231 Sutton Street, Suite 1B
North Andover, 01845
P: (978) 687-6200

Andover Department of Public Works:

5 Campanelli Drive
Andover, MA 01810
P: (978) 623-8700

Andover Planning Board:

Town Hall
36 Bartlet Street
Andover, MA 01810
P: (978) 623-8695

Owner Signature:

Erosion and Sedimentation Controls during Construction:

The site and drainage construction contractor shall be responsible for maintaining the stormwater system during construction. Routine maintenance of all items shall be performed to ensure adequate runoff and pollution control during construction.

A proposed construction fence and mulch sock will be placed as shown on the Demolition and Erosion Control Plan prior to the commencement of any clearing, grubbing, and earth removal or construction activity. The integrity of the erosion control barrier will be maintained by periodic inspection and replacement as necessary. The erosion control barrier will remain in place until the first course of pavement has been placed and all side slopes have been loamed and seeded and vegetation has been established. Silt sacks will also be placed over the new catch basins once constructed.

Operations and maintenance plans for the Stormwater Management construction phase and long term operation of the system have been attached to this report.

General Conditions

1. The developer shall be responsible for scheduling regular inspections and maintenance of the stormwater BMP's until such time when the homeowner's association is established at which time the homeowner's association shall become the responsible party. The BMP maintenance shall be conducted as detailed in the following long-term pollution prevention plan and illustrated on the approved design plans:
"Site Development Plans – 2-4 Buxton Court, 7-9 & 11 Lewis Street, 35 Pearson Street & 122 North Main Street - Andover, Massachusetts" prepared by The Morin-Cameron Group, Inc. dated November 15, 2023, revised on February 6, 2024. All Stormwater BMP's shall be operated and maintained in accordance with the design plans and the following Long-Term Pollution Prevention Plan.
2. The owner shall:
 - a. Maintain an Operation and Maintenance Log for the last three years. The Log shall include all BMP inspections, repairs, replacement activities and disposal activities (disposal material and disposal location shall be included in the Log);
 - b. Make the log available to the Andover Department of Public Works, Planning Board and Conservation Commission upon request;
 - c. Allow members and agents of the Andover Department of Public Works Planning Board and Conservation Commission to enter the premises and ensure that the Owner has complied with the Operation and Maintenance Plan requirements for each BMP.
3. A recommended inspection and maintenance schedule is outlined below based on statewide averages. This inspection and maintenance schedule shall be adhered to at
4. A minimum for the first year of service of all BMP's referenced in this document. At the commencement of the first year of service, a more accurate inspection/maintenance schedule shall be determined based on the level of service for this site.

Long-Term Pollution Prevention Plan (LTPPP)

Vegetated Areas:

Immediately after construction, monitoring of the erosion control systems shall occur until establishment of natural vegetation. Afterwards, vegetated areas shall be maintained as such. Vegetation shall be replaced as necessary to ensure proper stabilization of the site.

Cost: Included with annual landscaping budget. Consult with local landscape contractors.

Paved Areas:

Sweepers shall sweep paved areas periodically during dry weather to remove excess sediments and to reduce the amount of sediments that the drainage system shall have to remove from the runoff. The sweeping shall be conducted primarily between March 15th and November 15th. Special attention should be made to sweeping paved surfaces in March and April before spring rains wash residual sand into the drainage system. Sweeping shall occur at a minimum of twice per year (Spring and Fall).

Cost: \$100-\$300 per sweeping

Salt used for de-icing on the roadway during winter months shall be limited as much as possible as this will reduce the need for removal and treatment. Sand containing the minimum amount of calcium chloride (or approved equivalent) needed for handling may be applied as part of the routine winter maintenance activities.

CDS Water Quality Unit:

The CDS Water Quality Unit shall be inspected after every major storm event for the first 3 months after construction; a major storm event is 3.15 inches of rainfall within a twenty-four-hour period. Thereafter, the system shall be inspected twice per year in April and October. The units shall be cleaned per manufacturer's instructions included herein.

Cost: The owner shall consult local landscaping contractor for details.

Public Safety Concerns: The manhole covers shall not be left open and unattended at any time during inspection, cleaning or otherwise. Broken covers or frames shall be replaced immediately.

Subsurface Infiltration and Detention Galleys:

The subsurface infiltration and detention galleys and outlet structures shall be checked for debris accumulation twice per year. Each system is equipped with an inspection manhole on the first tank in the series and on the last tank in the series in addition to the inspection manholes for the sediment trap tanks. Additional inspections should be scheduled during the first few months to make sure that the facility is functioning as intended. Trash, leaves, branches, etc. shall be removed from facility. Silt, sand and sediment, if significant accumulation occurs, shall be removed annually. Material removed from the galleys shall be disposed of in accordance with all applicable local, state, and federal regulations. In the case that water remains in the infiltration facilities for greater than three (3) days after a storm event, an inspection is warranted and necessary maintenance or repairs should be addressed as necessary.

The outlet structure shall be inspected annually for structural integrity. The inspections shall be conducted by qualified personnel.

Cost: \$500-\$2,500 per cleaning depending on the volume of material/liquids that need to be removed.

Public Safety Concerns: The manhole covers shall not be left open and unattended at any time during inspection, cleaning or otherwise. Broken covers or frames shall be replaced immediately. At no time shall any person enter the subsurface structure unless measures have been taken to ensure safe access in accordance with OSHA enclosed space regulations.

Jellyfish Tank:

The jellyfish tank shall be checked for standing water, physical damage to the deck or cartridge lids, debris in the access wall or inlet bay for vault systems. Oil, floatable trash and debris shall be removed from facility. A minimum of quarterly inspections during the first year of operation to assess the sediment and floatable pollutant accumulation, and to ensure proper functioning of the system. The inspection frequency in subsequent shall be done twice per year, and after each major storm event. Material removed from the galleys shall be disposed of

The filter cartridges shall be rinsed and re-installed as required by the most recent inspection results, or within 12 months of the most recent filter rinsing, whichever occurs sooner. Replace tentacles if rinsing does not restore adequate hydraulic capacity, remove accumulated sediment, or if damaged or missing. It is recommended that tentacles should remain in service no longer than 5 years before replacement. Damaged or missing cartridge deck components must be repaired or replaced as indicated by results of the most recent inspection. The unit must be cleaned out and filter cartridges inspected immediately after an upstream oil, fuel, or chemical spill. Filter cartridge tentacles should be replaced if damaged or compromised by the spill. Rinsing should occur within a container and be disposed in accordance with all applicable local, state, and federal regulations.

Cost: The owner shall consult local contractors for details.

Overall Site Grading and Stormwater Management on Lots:

After construction, and during the initial vegetation establishment period, the site should be inspected after every rainfall. Mowing, litter removal, and spot vegetation repair should be performed on a regular basis.

Debris & Litter:

All debris and litter shall be removed from the driveway/parking area as necessary to prevent migration into the drainage system.

Pesticides, Herbicides, and Fertilizers:

Pesticides and herbicides shall be used sparingly. Fertilizers shall be restricted to the use of organic fertilizers only. All fertilizers, herbicides, pesticides, sand and salt for deicing and the like shall be stored in dry area that is protected from weather.

Cost: Included in the routine landscaping maintenance schedule. The Owner shall consult local landscaping contractors for details.

Public Safety Concerns: Chemicals shall be stored in a secure area to prevent children from obtaining access to them. Any major spills shall be reported to municipal officials.

Prevention of Illicit Discharges:

Illicit discharges to the stormwater management system are not allowed. Illicit discharges are discharges that are not comprised entirely of stormwater. Pursuant to Mass DEP Stormwater Standards the following activities or facilities are not considered illicit discharges: firefighting, water line flushing, landscape irrigation, uncontaminated groundwater, potable water sources, foundation drains, air

conditioning condensation, footing drains, individual resident car washing, flows from riparian habitats and wetlands, De-chlorinated water from swimming pools, water used for street washing and water used to clean residential building without detergents.

To prevent illicit discharges to the stormwater management system the following policies should be implemented:

1. Good Housekeeping Practices
 - The site shall be kept clean of litter and debris and continuously maintained in accordance with the Long-Term Pollution Prevention Plan as noted above. All chemicals shall be covered and stored in secured location. Any land disturbances that change drainage characteristics shall be remedied to pre-disturbance characteristics (i.e. shoulder rutting from vehicles, land disturbance from plowing, etc.) as soon as possible to ensure proper treatment of all stormwater runoff.
2. Provisions for Storing Materials and Waste Products Inside or Under Cover
 - All chemicals and chemical waste products shall be stored inside or in a secured covered location to prevent potential discharge. Any major spills shall be reported to municipal officials and a remediation plan shall be implemented immediately.
3. Vehicle Maintenance
 - Any vehicle maintenance shall be done with care to prevent discharge of illicit fluids. If fluids are accidentally spilled, immediate action shall be implemented to clean and remove the fluid to prevent discharge into the stormwater management system and/or infiltrating into the groundwater.
4. Spill Prevention and Response Plans
 - If a major spill of an illicit substance occurs, town officials (including but not limited to the Fire Department and Police Department) shall be notified immediately. A response plan shall then be implemented immediately to prevent any illicit discharges from entering the stormwater management system and ultimately surface waters of the Commonwealth.
5. Solid waste
 - All domestic solid waste shall be disposed of in accordance with all applicable local, state and federal regulations. Waste shall be placed into covered dumpsters and/or covered waste bins to prevent water intrusion and potentially contaminated runoff. No household chemicals, hazardous materials, construction debris or non-household generated refuse shall be disposed of in the on-site waste disposal containers.
6. Pet waste: Pet waste bag dispensers & waste receptacles shall be provided for trash and pet waste disposal. Depending on usage and season, the receptacles shall be maintained once or twice weekly by the Owner to ensure adequate disposal occurs. The park rules shall include measures for pet waste pick up responsibility by the pet owners.

TABLE 1: MAINTENANCE SCHEDULE FOR DRAINAGE STRUCTURES

Structure	Inspection	Maintenance
Subsurface Recharge System, CDS Water Quality Structure, Drain Manhole, Jelly Fish Tank, Area Drains, Catch Bains	Inspect after every major storm event for first 3 months after construction to ensure the structures are working properly.* Thereafter, twice a year (April / October) Inspections should include the following: <ul style="list-style-type: none"> • Signs of differential settlement • Erosion • Tree growth on the embankments that were not part of the design plan • Sediment accumulation • Health of turf • Cracked/Disconnected Roof Leaders • Clogged orifices, pipe obstructions 	Rehabilitate structure if it fails due to clogging as generally evidenced by retention of water for more than 72 hours after a storm event Remove any obstructions from outlets/pipes Remove accumulated sediment
* Major storm event: 3.2 inches of rainfall in a 24 hour period (2 year storm)		

Stormwater System Maintenance Log

Andover Town Yard, Andover, MA

The Following structures shall be inspected and maintained by the owner.

BMP STRUCTURE	INSPECTION DATE	WORK PERFORMED	DATE WORK PERFORMED	COMMENTS
Stormwater Management Infrastructure				
Subsurface Recharge System				
JellyFish Filter 1 (JF-1)				
Outlet Control Structure (OCS-1)				
Water Quality Unit 1 (SWQU-1)				
Water Quality Unit 2 (WQU-2)				
DMH-1				

DMH-2				
DMH-3				
DMH-4				
DMH-5				
DMH-6				
DMH-7				
DMH-8				

DMH-9				
DMH-10				
DMH-11				
DMH-12				
DMH-13				
DMH-14				
AD-1				

AD-2				
AD-3				
AD-4				
CB-1				
CB-2				
CB-3				
CB-4				

CB-5				
CB-6				
CB-7				
CB-8				
CB-9				
CB-10				
CB-11				

CB-12				
CB-13				

Jellyfish Filter Inspection and Maintenance Log

Owner:		Jellyfish Model No:	
Location:		GPS Coordinates:	
Land Use:	Commercial:	Industrial:	Service Station:
	Roadway/Highway:	Airport:	Residential:

Date/Time:						
Inspector:						
Maintenance Contractor:						
Visible Oil Present: (Y/N)						
Oil Quantity Removed:						
Floatable Debris Present: (Y/N)						
Floatable Debris Removed: (Y/N)						
Water Depth in Backwash Pool						
Draindown Cartridges externally rinsed and recommissioned: (Y/N)						
New tentacles put on Draindown Cartridges: (Y/N)						
Hi-Flo Cartridges externally rinsed and recommissioned: (Y/N)						
New tentacles put on Hi-Flo Cartridges: (Y/N)						
Sediment Depth Measured: (Y/N)						
Sediment Depth (inches or mm):						
Sediment Removed: (Y/N)						
Cartridge Lids intact: (Y/N)						
Observed Damage:						
Comments:						

"ANDOVER TOWN YARD"
OPERATIONS AND
MAINTENANCE PLAN
DATED: 01/20/2024

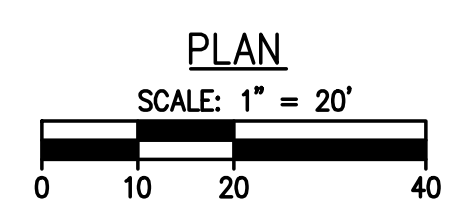
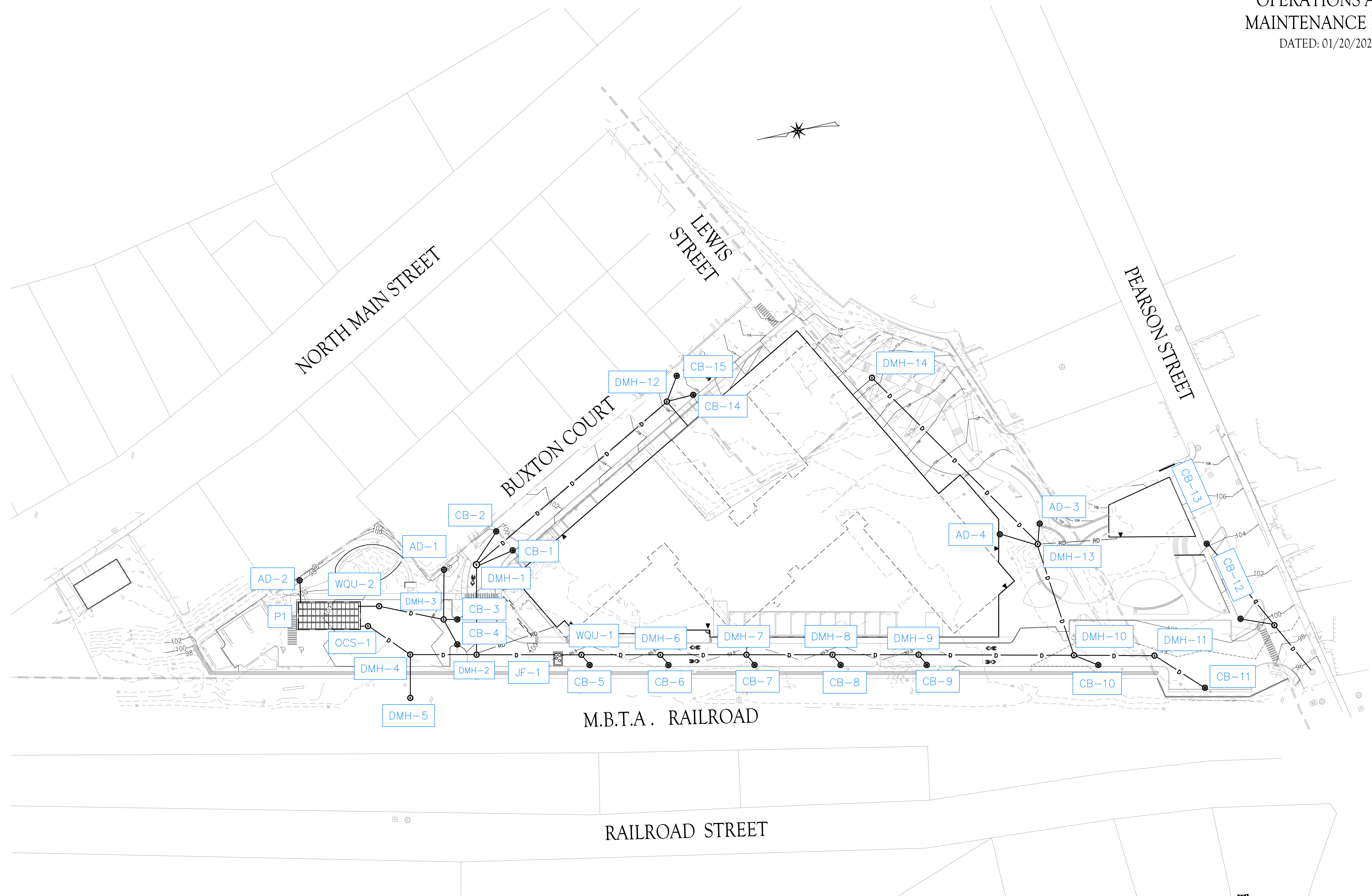

Jellyfish[®] Filter Maintenance Guide

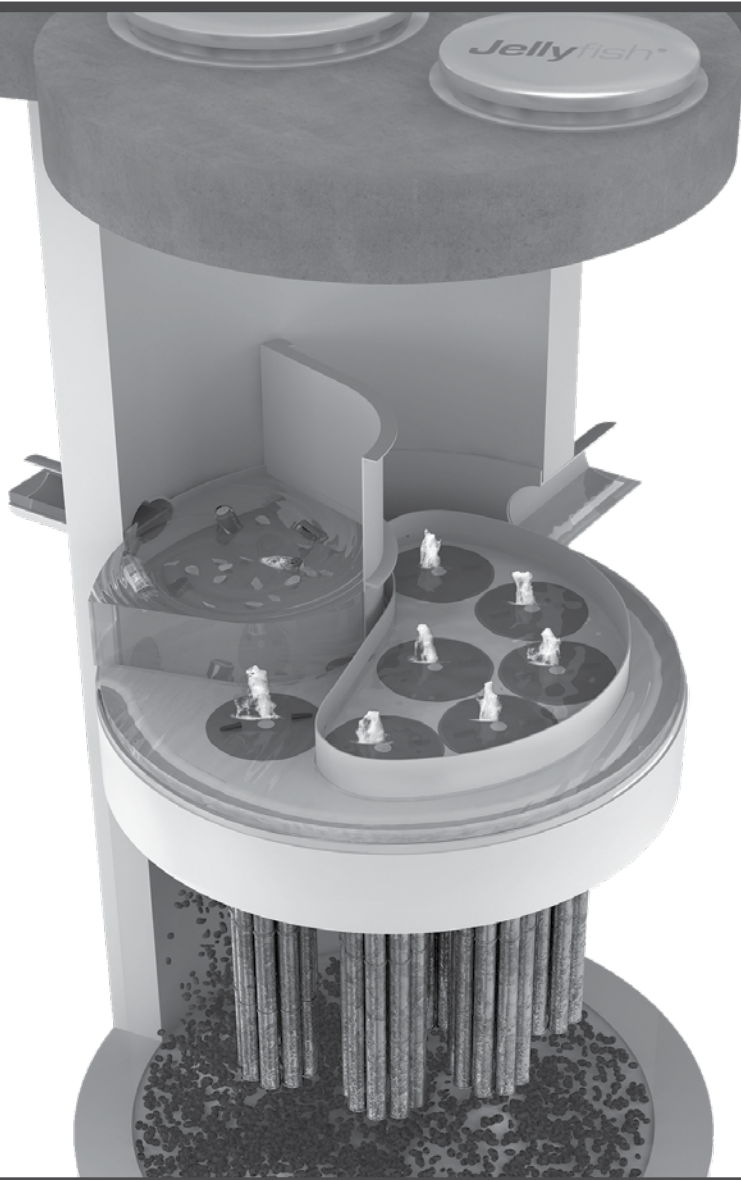



JELLYFISH® FILTER INSPECTION & MAINTENANCE GUIDE

Jellyfish units are often just one of many structures in a more comprehensive stormwater drainage and treatment system.

In order for maintenance of the Jellyfish filter to be successful, it is imperative that all other components be properly maintained. The maintenance and repair of upstream facilities should be carried out prior to Jellyfish maintenance activities.

In addition to considering upstream facilities, it is also important to correct any problems identified in the drainage area. Drainage area concerns may include: erosion problems, heavy oil loading, and discharges of inappropriate materials.

TABLE OF CONTENTS

Inspection and Maintenance Overview	3
Inspection Procedure.....	3
Maintenance Procedure.....	4
Cartridge Assembly & Cleaning.....	5
Inspection Process	7

1.0 Inspection and Maintenance Overview

The primary purpose of the Jellyfish® Filter is to capture and remove pollutants from stormwater runoff. As with any filtration system, these pollutants must be removed to maintain the filter's maximum treatment performance. Regular inspection and maintenance are required to insure proper functioning of the system.

Maintenance frequencies and requirements are site specific and vary depending on pollutant loading. Additional maintenance activities may be required in the event of non-storm event runoff, such as base-flow or seasonal flow, an upstream chemical spill or due to excessive sediment loading from site erosion or extreme runoff events. It is a good practice to inspect the system after major storm events.

Inspection activities are typically conducted from surface observations and include:

- Observe if standing water is present
- Observe if there is any physical damage to the deck or cartridge lids
- Observe the amount of debris in the Maintenance Access Wall (MAW) or inlet bay for vault systems

Maintenance activities include:

- Removal of oil, floatable trash and debris
- Removal of collected sediments
- Rinsing and re-installing the filter cartridges
- Replace filter cartridge tentacles, as needed

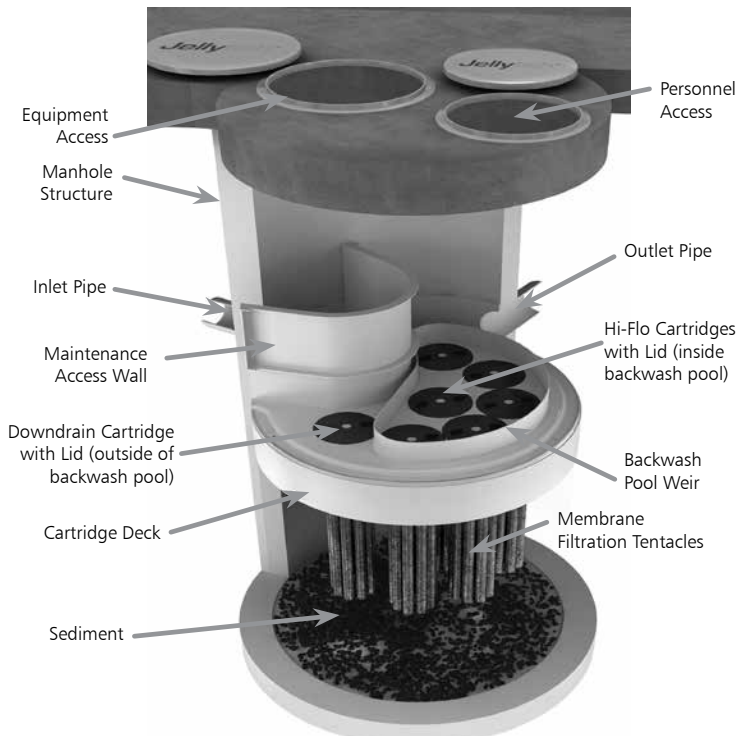

Note: Separator Skirt not shown

2.0 Inspection Timing

Inspection of the Jellyfish Filter is key in determining the maintenance requirements for, and to develop a history of, the site's pollutant loading characteristics. In general, inspections should be performed at the times indicated below; *or per the approved project stormwater quality documents (if applicable), whichever is more frequent.*

1. A minimum of quarterly inspections during the first year of operation to assess the sediment and floatable pollutant accumulation, and to ensure proper functioning of the system.
2. Inspection frequency in subsequent years is based on the inspection and maintenance plan developed in the first year of operation. Minimum frequency should be once per year.
3. Inspection is recommended after each major storm event.
4. Inspection is required immediately after an upstream oil, fuel or other chemical spill.

3.0 Inspection Procedure

The following procedure is recommended when performing inspections:

1. Provide traffic control measures as necessary.
2. Inspect the MAW or inlet bay for floatable pollutants such as trash, debris, and oil sheen.
3. Measure oil and sediment depth in several locations, by lowering a sediment probe until contact is made with the floor of the structure. Record sediment depth, and presences of any oil layers.
4. Inspect cartridge lids. Missing or damaged cartridge lids to be replaced.
5. Inspect the MAW (where appropriate), cartridge deck and receptacles, and backwash pool weir, for damaged or broken components.

3.1 Dry weather inspections

- Inspect the cartridge deck for standing water, and/or sediment on the deck.
- No standing water under normal operating conditions.
- Standing water inside the backwash pool, but not outside the backwash pool indicates, that the filter cartridges need to be rinsed.

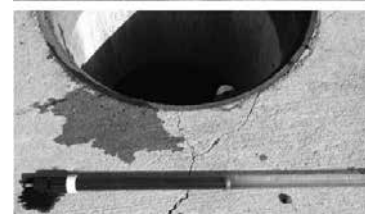

Inspection Utilizing Sediment Probe

- Standing water outside the backwash pool is not anticipated and may indicate a backwater condition caused by high water elevation in the receiving water body, or possibly a blockage in downstream infrastructure.
- Any appreciable sediment ($\geq 1/16''$) accumulated on the deck surface should be removed.

3.2 Wet weather inspections

- Observe the rate and movement of water in the unit. Note the depth of water above deck elevation within the MAW or inlet bay.
- Less than 6 inches, flow should be exiting the cartridge lids of each of the draindown cartridges (i.e. cartridges located outside the backwash pool).
- Greater than 6 inches, flow should be exiting the cartridge lids of each of the draindown cartridges and each of the hi-flo cartridges (i.e. cartridges located inside the backwash pool), and water should be overflowing the backwash pool weir.
- 18 inches or greater and relatively little flow is exiting the cartridge lids and outlet pipe, this condition indicates that the filter cartridges need to be rinsed.

4.0 Maintenance Requirements

Required maintenance for the Jellyfish Filter is based upon results of the most recent inspection, historical maintenance records, or the site specific water quality management plan; whichever is more frequent. In general, maintenance requires some combination of the following:

1. Sediment removal for depths reaching 12 inches or greater, or within 3 years of the most recent sediment cleaning, whichever occurs sooner.
2. Floatable trash, debris, and oil removal.
3. Deck cleaned and free from sediment.
4. Filter cartridges rinsed and re-installed as required by the most recent inspection results, or within 12 months of the most recent filter rinsing, whichever occurs sooner.
5. Replace tentacles if rinsing does not restore adequate hydraulic capacity, remove accumulated sediment, or if damaged or missing. It is recommended that tentacles should remain in service no longer than 5 years before replacement.
6. Damaged or missing cartridge deck components must be repaired or replaced as indicated by results of the most recent inspection.
7. The unit must be cleaned out and filter cartridges inspected immediately after an upstream oil, fuel, or chemical spill. Filter cartridge tentacles should be replaced if damaged or compromised by the spill.

5.0 Maintenance Procedure

The following procedures are recommended when maintaining the Jellyfish Filter:

1. Provide traffic control measures as necessary.
2. Open all covers and hatches. Use ventilation equipment as required, according to confined space entry procedures.
Caution: Dropping objects onto the cartridge deck may cause damage.

3. Perform Inspection Procedure prior to maintenance activity.
4. To access the cartridge deck for filter cartridge service, descend into the structure and step directly onto the deck. Caution: Do not step onto the maintenance access wall (MAW) or backwash pool weir, as damage may result. Note that the cartridge deck may be slippery.
5. Maximum weight of maintenance crew and equipment on the cartridge deck not to exceed 450 lbs.

5.1 Filter Cartridge Removal

1. Remove a cartridge lid.
2. Remove cartridges from the deck using the lifting loops in the cartridge head plate. Rope or a lifting device (available from Contech) should be used. **Caution: Should a snag occur, do not force the cartridge upward as damage to the tentacles may result. Wet cartridges typically weigh between 100 and 125 lbs.**
3. Replace and secure the cartridge lid on the exposed empty receptacle as a safety precaution. Contech does not recommend exposing more than one empty cartridge receptacle at a time.

5.2 Filter Cartridge Rinsing

1. Remove all 11 tentacles from the cartridge head plate. Take care not to lose or damage the O-ring seal as well as the plastic threaded nut and connector.



Cartridge Removal & Lifting Device



2. Position tentacles in a container (or over the MAW), with the threaded connector (open end) facing down, so rinse water is flushed through the membrane and captured in the container.
3. Using the Jellyfish rinse tool (available from Contech) or a low-pressure garden hose sprayer, direct water spray onto the tentacle membrane, sweeping from top to bottom along the length of the tentacle. Rinse until all sediment is removed from the membrane. **Caution: Do not use a high pressure sprayer or focused stream of water on the membrane. Excessive water pressure may damage the membrane.**

4. Collected rinse water is typically removed by vacuum hose.
5. Reassemble cartridges as detailed later in this document. Reuse O-rings and nuts, ensuring proper placement on each tentacle.

5.3 Sediment and Floatables Extraction

1. Perform vacuum cleaning of the Jellyfish Filter only after filter cartridges have been removed from the system. Access the lower chamber for vacuum cleaning only through the maintenance access wall (MAW) opening. Be careful not to damage the flexible plastic separator skirt that is attached to the underside of the deck on manhole systems. Do not lower the vacuum wand through a cartridge receptacle, as damage to the receptacle will result.
2. Vacuum floatable trash, debris, and oil, from the MAW opening or inlet bay. Alternatively, floatable solids may be removed by a net or skimmer.



Vacuuming Sump Through MAW

3. Pressure wash cartridge deck and receptacles to remove all sediment and debris. Sediment should be rinsed into the sump area. Take care not to flush rinse water into the outlet pipe.
4. Remove water from the sump area. Vacuum or pump equipment should only be introduced through the MAW or inlet bay.
5. Remove the sediment from the bottom of the unit through the MAW or inlet bay opening.



Vacuuming Sump Through MAW

6. For larger diameter Jellyfish Filter manholes (≥ 8 -ft) and some vaults complete sediment removal may be facilitated by removing a cartridge lid from an empty receptacle and inserting a jetting wand (not a vacuum wand) through the receptacle. Use the sprayer to rinse loosened sediment toward the vacuum hose in the MAW opening, being careful not to damage the receptacle.

5.4 Filter Cartridge Reinstallation and Replacement

1. Cartridges should be installed after the deck has been cleaned. It is important that the receptacle surfaces be free from grit and debris.
2. Remove cartridge lid from deck and carefully lower the filter cartridge into the receptacle until head plate gasket is seated squarely in receptacle. **Caution: Do not force the cartridge downward; damage may occur.**
3. Replace the cartridge lid and check to see that both male threads are properly seated before rotating approximately 1/3 of a full rotation until firmly seated. Use of an approved rim gasket lubricant may facilitate installation. See next page for additional details.
4. If rinsing is ineffective in removing sediment from the tentacles, or if tentacles are damaged, provisions must be made to replace the spent or damaged tentacles with new tentacles. Contact Contech to order replacement tentacles.

5.5 Chemical Spills

Caution: If a chemical spill has been captured, do not attempt maintenance. Immediately contact the local hazard response agency and contact Contech.

5.6 Material Disposal

The accumulated sediment found in stormwater treatment and conveyance systems must be handled and disposed of in accordance with regulatory protocols. It is possible for sediments to contain measurable concentrations of heavy metals and organic chemicals (such as pesticides and petroleum products). Areas with the greatest potential for high pollutant loading include industrial areas and heavily traveled roads. Sediments and water must be disposed of in accordance with all applicable waste disposal regulations. When scheduling maintenance, consideration must be made for the disposal of solid and liquid wastes. This typically requires coordination with a local landfill for solid waste disposal. For liquid waste disposal a number of options are available including a municipal vacuum truck decant facility, local waste water treatment plant or on-site treatment and discharge.

Jellyfish Filter Components & Filter Cartridge Assembly and Installation

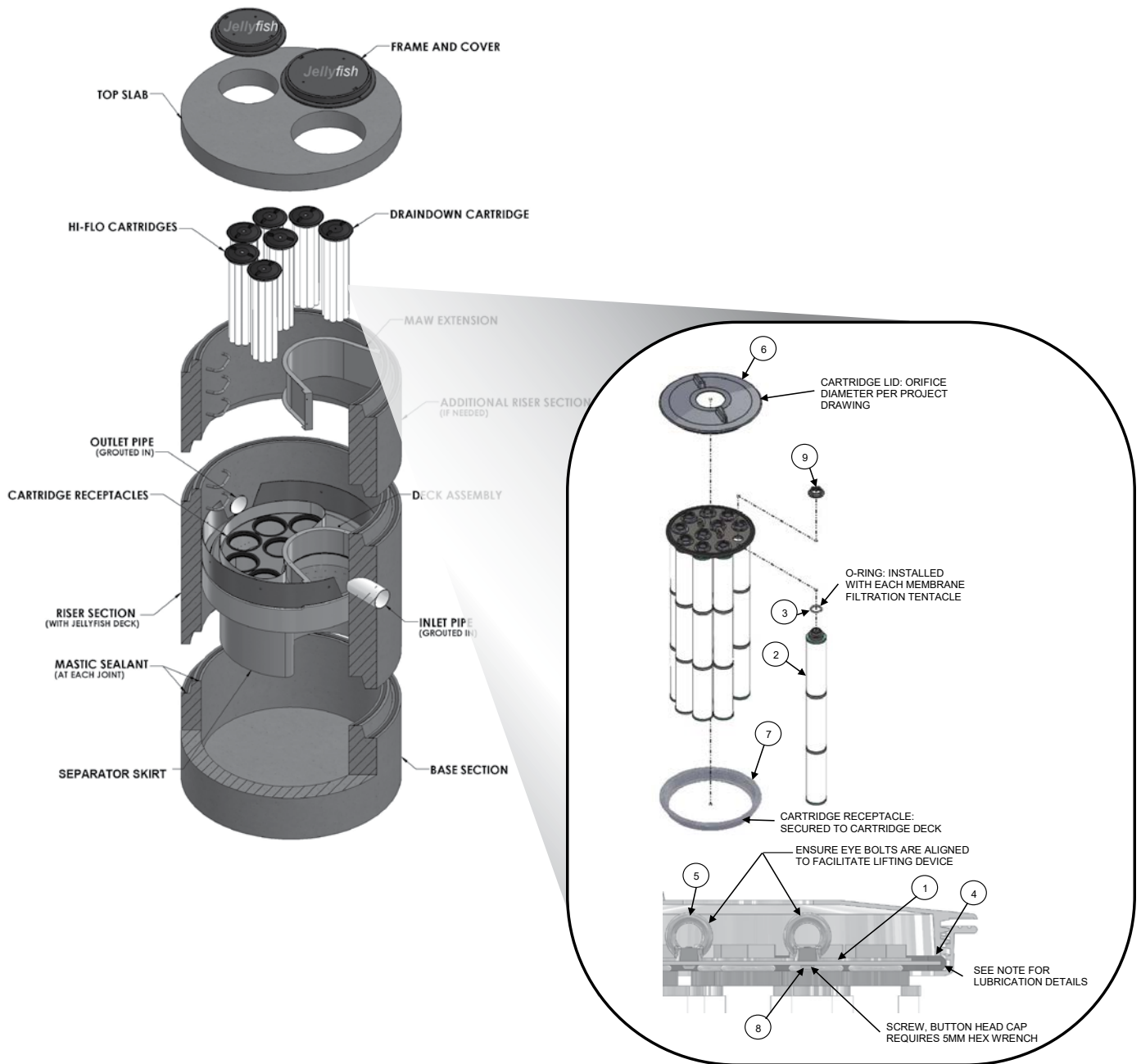

TABLE 1: BOM

ITEM NO.	DESCRIPTION
1	JF HEAD PLATE
2	JF TENTACLE
3	JF O-RING
4	JF HEAD PLATE GASKET
5	JF CARTRIDGE EYELET
6	JF 14IN COVER
7	JF RECEPTACLE
8	BUTTON HEAD CAP SCREW M6X14MM SS
9	JF CARTRIDGE NUT

TABLE 2: APPROVED GASKET LUBRICANTS

PART NO.	MFR	DESCRIPTION
78713	LA-CO	LUBRI-JOINT
40501	HERCULES	DUCK BUTTER
30600	OATEY	PIPE LUBRICANT
PSLUBXL1Q	PROSELECT	PIPE JOINT LUBRICANT

NOTES:

Head Plate Gasket Installation:

Install Head Plate Gasket (Item 4) onto the Head Plate (Item 1) and liberally apply a lubricant from Table 2: Approved Gasket Lubricants onto the gasket where it contacts the Receptacle (Item 7) and Cartridge Lide (Item 6). Follow Lubricant manufacturer's instructions.

Lid Assembly:

Rotate Cartridge Lid counter-clockwise until both male threads drop down and properly seat. Then rotate Cartridge Lid clock-wise approximately one-third of a full rotation until Cartridge Lid is firmly secured, creating a watertight seal.



Support

- Drawings and specifications are available at www.conteches.com/jellyfish.
- Site-specific design support is available from Contech Engineered Solutions.
- Find a Certified Maintenance Provider at www.conteches.com/ccmp

Jellyfish[®]

CONTECH[®]
ENGINEERED SOLUTIONS

800.338.1122

www.ContechES.com

© 2021 Contech Engineered Solutions LLC, a QUIKRETE Company

Contech Engineered Solutions LLC provides site solutions for the civil engineering industry. Contech's portfolio includes bridges, drainage, sanitary sewer, stormwater, wastewater treatment and earth stabilization products. For information on other Contech segment offerings, visit ContechES.com or call 800.338.1122

NOTHING IN THIS CATALOG SHOULD BE CONSTRUED AS A WARRANTY. APPLICATIONS SUGGESTED HEREIN ARE DESCRIBED ONLY TO HELP READERS MAKE THEIR OWN EVALUATIONS AND DECISIONS, AND ARE NEITHER GUARANTEES NOR WARRANTIES OF SUITABILITY FOR ANY APPLICATION. CONTECH MAKES NO WARRANTY WHATSOEVER, EXPRESS OR IMPLIED, RELATED TO THE APPLICATIONS, MATERIALS, COATINGS, OR PRODUCTS DISCUSSED HEREIN. ALL IMPLIED WARRANTIES OF MERCHANTABILITY AND ALL IMPLIED WARRANTIES OF FITNESS FOR ANY PARTICULAR PURPOSE ARE DISCLAIMED BY CONTECH. SEE CONTECH'S CONDITIONS OF SALE (AVAILABLE AT WWW.CONTECHES.COM/COS) FOR MORE INFORMATION.

Cascade Separator[®] Inspection and Maintenance Guide



Maintenance

The Cascade Separator® system should be inspected at regular intervals and maintained when necessary to ensure optimum performance. The rate at which the system collects sediment and debris will depend upon on-site activities and site pollutant characteristics. For example, unstable soils or heavy winter sanding will cause the sediment storage sump to fill more quickly but regular sweeping of paved surfaces will slow accumulation.

Inspection

Inspection is the key to effective maintenance and is easily performed. Pollutant transport and deposition may vary from year to year and regular inspections will help ensure that the system is cleaned out at the appropriate time. At a minimum, inspections should be performed twice per year (i.e. spring and fall). However, more frequent inspections may be necessary in climates where winter sanding operations may lead to rapid accumulations, or in equipment wash-down areas. Installations should also be inspected more frequently where excessive amounts of trash are expected.

A visual inspection should ascertain that the system components are in working order and that there are no blockages or obstructions in the inlet chamber, flumes or outlet channel. The inspection should also quantify the accumulation of hydrocarbons, trash and sediment in the system. Measuring pollutant accumulation can be done with a calibrated dipstick, tape measure or other measuring instrument. If absorbent material is used for enhanced removal of hydrocarbons, the level of discoloration of the sorbent material should also be identified during inspection. It is useful and often required as part of an operating permit to keep a record of each inspection. A simple form for doing so is provided in this Inspection and Maintenance Guide.

Access to the Cascade Separator unit is typically achieved through one manhole access cover. The opening allows for inspection and cleanout of the center chamber (cylinder) and sediment storage sump, as well as inspection of the inlet chamber and slanted skirt. For large units, multiple manhole covers allow access to the chambers and sump.

The Cascade Separator system should be cleaned before the level of sediment in the sump reaches the maximum sediment depth and/or when an appreciable level of hydrocarbons and trash has accumulated. If sorbent material is used, it must be replaced when significant discoloration has occurred. Performance may be impacted when maximum sediment storage capacity is exceeded. Contech recommends maintaining the system when sediment level reaches 50% of maximum storage volume. The level of sediment is easily determined by measuring the distance from the system outlet invert (standing water level) to the top of the sediment pile. To avoid underestimating the level of sediment in the chamber, the measuring device must be lowered to the top of the sediment pile carefully. Finer, silty particles at the top of the pile typically offer less resistance to the end of the rod than larger particles toward the bottom of the pile. Once this measurement is recorded, it should be compared to the chart in this document to determine if the height of the sediment pile off the bottom of the sump floor exceeds 50% of the maximum sediment storage.

Cleaning

Cleaning of a Cascade Separator system should be done during dry weather conditions when no flow is entering the system. The use of a vacuum truck is generally the most effective and convenient method of removing pollutants from the system. Simply remove the manhole cover and insert the vacuum tube down through the center chamber and into the sump. The system should be completely drained down and the sump fully evacuated of sediment. The areas outside the center chamber and the slanted skirt should also be washed off if pollutant build-up exists in these areas.

In installations where the risk of petroleum spills is small, liquid contaminants may not accumulate as quickly as sediment. However, the system should be cleaned out immediately in the event of an oil or gasoline spill. Motor oil and other hydrocarbons that accumulate on a more routine basis should be removed when an appreciable layer has been captured. To remove these pollutants, it may be preferable to use absorbent pads since they are usually less expensive to dispose than the oil/water emulsion that may be created by vacuuming the oily layer. Trash and debris can be netted out to separate it from the other pollutants. Then the system should be power washed to ensure it is free of trash and debris.

Manhole covers should be securely seated following cleaning activities to prevent leakage of runoff into the system from above and to ensure proper safety precautions. Confined space entry procedures need to be followed if physical access is required. Disposal of all material removed from the Cascade Separator system must be done in accordance with local regulations. In many locations, disposal of evacuated sediments may be handled in the same manner as disposal of sediments removed from catch basins or deep sump manholes. Check your local regulations for specific requirements on disposal. If any components are damaged, replacement parts can be ordered from the manufacturer.

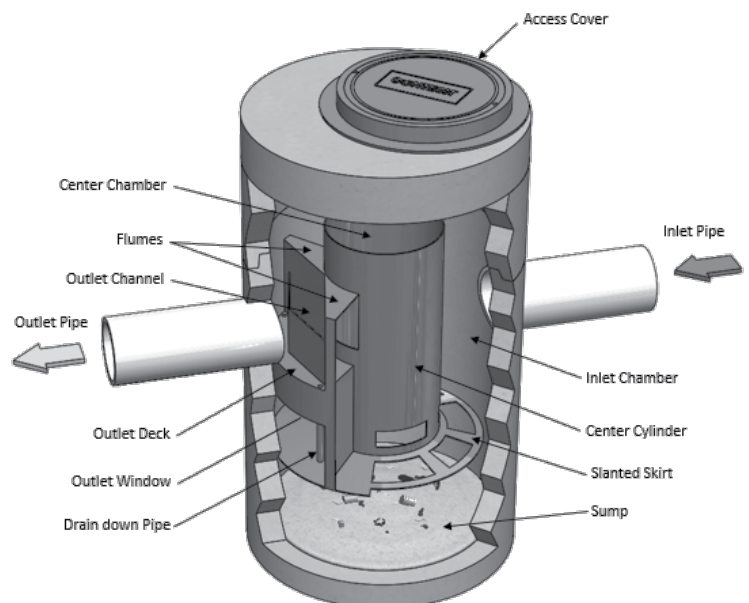

Cascade Separator® Maintenance Indicators and Sediment Storage Capacities

Model Number	Diameter		Distance from Water Surface to Top of Sediment Pile		Sediment Storage Capacity	
	ft	m	ft	m	y ³	m ³
CS-3	3	0.9	1.5	0.5	0.4	0.3
CS-4	4	1.2	2.5	0.8	0.7	0.5
CS-5	5	1.3	3	0.9	1.1	0.8
CS-6	6	1.8	3.5	1	1.6	1.2
CS-8	8	2.4	4.8	1.4	2.8	2.1
CS-10	10	3.0	6.2	1.9	4.4	3.3
CS-12	12	3.6	7.5	2.3	6.3	4.8

Note: The information in the chart is for standard units. Units may have been designed with non-standard sediment storage depth.



A Cascade Separator unit can be easily cleaned in less than 30 minutes.



A vacuum truck excavates pollutants from the systems.

**APPENDIX G:
ILLCIT
DISCHARGE STATEMENT**

Illicit Discharge Compliance Statement

I, Scott P. Cameron, P.E., hereby notify the Andover Planning Board that I have not witnessed, nor am aware of any existing illicit discharges at the site known as “Andover Town Yard”, 2-4 Buxton Court, 7-9 & 11 Lewis Street, 35 Pearson Street, 122 North Main Street, Andover, Massachusetts. I also hereby certify that the development of said property as illustrated on the final plans entitled “Site Development Plans, 2-4 Buxton Court, 7-9 & 11 Lewis Street, 35 Pearson Street and 122 North Main Street, Andover, Massachusetts” prepared by The Morin-Cameron Group, Inc. dated November 15, 2023, revised on February 20, 2024 and as revised and approved by the Andover Planning Board and maintenance thereof in accordance with the “Construction Phase Best Management Practices” and “Long Term Stormwater Best Management Practices” prepared by The Morin-Cameron Group, Inc dated November 15, 2023, revised on February 20, 2024 will not create any new illicit discharges. There is no warranty implied regarding future illicit discharges that may occur as a result of improper construction or maintenance of the stormwater management system or unforeseen accidents.

Name: Scott P. Cameron, P.E.

Company: The Morin-Cameron Group, Inc.

Title: Owner's Representative

Signature: 

Date: 2-21-24

Owner: _____

Signature: _____

Date: _____

**APPENDIX H:
SOIL BORING LOGS**

TEST BORING LOG



GZA
GeoEnvironmental, Inc.
Engineers and Scientists

Buxton Redevelopment, LLC
Andover Town Yard Development
11 Lewis Street
Andover, Massachusetts

BORING NO.: GZ-1
SHEET: 1 of 1
PROJECT NO: 18.0175728.00
REVIEWED BY: LWP

Drilling Co.: Drilex Environmental, Inc.	Type of Rig: Truck	Boring Location: See Plan	H. Datum:
Foreman: Enzo Gravante	Rig Model: CME 75	Ground Surface Elev. (ft.): 95	V. Datum: NAVD88
Logged By: Anthony Lupo	Drilling Method: HSA	Final Boring Depth (ft.): 27	
		Date Start - Finish: 8/1/2022 - 8/1/2022	

Auger/Casing Type: HSA	Sampler Type: Split Spoon	Groundwater Depth (ft.)		
I.D./O.D.(in.): 4.25/7.625	I.D./O.D. (in.): 1.375/2	Date	Time	Water Depth
Hammer Weight (lb.): -	Sampler Hmr Wt (lb): 140	Not	recorded	
Hammer Fall (in.): -	Sampler Hmr Fall (in): 30			
Other: -	Other: Autohammer			

Depth (ft)	Casing Blows/ Core Rate	Sample						Sample Description and Identification (Modified Burmister Procedure)	Remark	Field Test Data	Stratum Description	Depth (ft.)	Elev. (ft.)
		No.	Depth (ft.)	Pen. (in)	Rec. (in)	Blows (per 6 in.)	SPT Value						
		S-1	0-2	24	9	7 6 3 2	9	S-1: Loose, dark brown/brown, fine to coarse SAND, some Gravel, little Silt, trace Organics, trace Asphalt, trace Glass.	1		0.5'	94.5'	
		S-2	2-4	24	9	2 3 10 12	13	S-2: (Top 7") Dark brown/brown, fine to coarse SAND and GRAVEL, little Silt.	2		4'	91.0'	
5		S-3	4-6	24	12	13 18 23 22	41	S-2: (Bottom 2") Brown/tan, fine to coarse SAND and GRAVEL, trace Silt. S-3: Dense, brown/tan, fine to coarse SAND and GRAVEL, trace Silt.					
10		S-4	10-12	24	9	11 15 18 17	33	S-4: Dense, brown, fine to coarse SAND and GRAVEL, little Silt.	3		12'	83.0'	
15		S-5	15-17	24	15	21 24 16 18	40	S-5: Dense, brown, fine to coarse SAND and GRAVEL, some Silt.	4				
20		S-6	20-22	24	16	8 23 22 33	45	S-6: Hard, gray/brown, CLAY & SILT, some fine to coarse Sand, some Gravel.					
25		S-7	25-27	24	24	17 17 16 33	33	S-7: Hard, gray/brown, CLAY & SILT, little fine to medium Sand, trace Gravel.			27'	68.0'	
30		Bottom of boring at 27 feet.							5				

REMARKS

1. Ground surface elevation estimated from Town of Andover GIS website.
2. Wet soils observed beginning at approximately 4 feet below ground surface (bgs).
3. Increase in drill effort observed at approximately 12 feet bgs.
4. Increase in drill effort observed at approximately 22 feet bgs.
5. Upon completion borehole backfilled with soil cuttings to approximate ground surface.

See Log Key for explanation of sample description and identification procedures. Stratification lines represent approximate boundaries between soil and bedrock types. Actual transitions may be gradual. Water level readings have been made at the times and under the conditions stated. Fluctuations of groundwater may occur due to other factors than those present at the times the measurements were made.

Boring No.:
GZ-1

TEST BORING LOG



GZA
GeoEnvironmental, Inc.
Engineers and Scientists

Buxton Redevelopment, LLC
Andover Town Yard Development
11 Lewis Street
Andover, Massachusetts

BORING NO.: GZ-4
SHEET: 1 of 1
PROJECT NO: 18.0175728.00
REVIEWED BY: LWP

Drilling Co.: Drilex Environmental, Inc.	Type of Rig: Truck	Boring Location: See Plan	H. Datum:
Foreman: Enzo Gravante	Rig Model: CME 75	Ground Surface Elev. (ft.): 105	V. Datum: NAVD88
Logged By: Anthony Lupo	Drilling Method: HSA	Final Boring Depth (ft.): 28	
		Date Start - Finish: 8/3/2022 - 8/3/2022	

Auger/Casing Type: HSA	Sampler Type: Split Spoon	Groundwater Depth (ft.)		
I.D./O.D.(in): 4.25/7.625	I.D./O.D. (in.): 1.375/2	Date	Time	Water Depth
Hammer Weight (lb.): -	Sampler Hmr Wt (lb): 140	8/3/22	0945	25.2
Hammer Fall (in.): -	Sampler Hmr Fall (in): 30			Casing
Other: -	Other: Autohammer			Stab. Time
				28
				0 min.

Depth (ft)	Casing Blows/ Core Rate	Sample					SPT Value	Sample Description and Identification (Modified Burmister Procedure)	Remark	Field Test Data	Depth (ft.)	Stratum Description	Elev. (ft.)
		No.	Depth (ft.)	Pen. (in)	Rec. (in)	Blows (per 6 in.)							
5		S-1	0-2	24	10	5 2 5 2	7	S-1: Loose, dark brown/brown, fine to coarse SAND and GRAVEL, some Silt, trace Asphalt.	1		0.5'	ASPHALT	104.5'
		S-2	2-4	24	12	4 1 2 1	3	S-2: Very loose, brown, fine to coarse SAND, little Gravel, little Silt.					
		S-3	4-6	24	7	1 1 1 1	2	S-3: Very loose, dark brown, fine to coarse SAND, some Gravel, little Silt, trace Asphalt.				FILL	
		S-4	6-8	24	5	2 1 2 1	3	S-4: Very loose, dark brown, fine to medium SAND and GRAVEL, little Silt & Clay.					
10		S-5	10-12	24	12	7 17 12 11	29	S-5: (Top 6") Dark brown, fine to coarse SAND, some Gravel, some Silt. S-5: (Bottom 6") Brown, fine to medium SAND, some Clayey Silt, little Gravel.	2		11'		94.0'
		S-6	15-17	24	19	7 10 11 10	21	S-6: Medium dense, brown, fine to medium SAND, little Gravel, little Silt.	3			SAND AND GRAVEL	
20		S-7	20-22	24	17	15 24 45 27	69	S-7: Very dense, brown/gray, fine to medium SAND and Clayey SILT, little Gravel.			17'		88.0'
		S-8	25-27	24	21	31 40 50 50	90	S-8: Very dense, brown/gray, fine to medium SAND, some Silt, some Gravel.				GLACIAL TILL	
								Bottom of boring at 28 feet.	4 5		28'		77.0'

REMARKS

- Ground surface elevation estimated from Town of Andover GIS webiste.
- Increase in drill effort on likely cobbles observed between 11.5 and 13.5 feet below ground surface (bgs).
- Wet soils observed beginning at approximately 15 feet bgs. Groundwater depth measured at 0945 hours may not represent stabilized conditions.
- Auger refusal observed at approximately 28 feet bgs using up to 1200 psi of down pressure for 5 minutes with no advancement.
- Upon completion borehole backfilled with soil cuttings to approximate ground surface.

See Log Key for explanation of sample description and identification procedures. Stratification lines represent approximate boundaries between soil and bedrock types. Actual transitions may be gradual. Water level readings have been made at the times and under the conditions stated. Fluctuations of groundwater may occur due to other factors than those present at the times the measurements were made.

Boring No.:
GZ-4

18.0175728.00 11 LEWIS ST ANDOVER MA.GPJ; STRATUM ONLY NORWOOD; 8/26/2022

TEST BORING LOG



GZA
GeoEnvironmental, Inc.
Engineers and Scientists

Buxton Redevelopment, LLC
Andover Town Yard Development
11 Lewis Street
Andover, Massachusetts

BORING NO.: GZ-5
SHEET: 1 of 1
PROJECT NO: 18.0175728.00
REVIEWED BY: LWP

Drilling Co.: Drilex Environmental, Inc.	Type of Rig: Truck	Boring Location: See Plan	H. Datum:
Foreman: Enzo Gravante	Rig Model: CME 75	Ground Surface Elev. (ft.): 99	V. Datum: NAVD88
Logged By: Anthony Lupo	Drilling Method: HSA	Final Boring Depth (ft.): 10.5	
		Date Start - Finish: 8/1/2022 - 8/1/2022	

Auger/Casing Type: HSA	Sampler Type: Split Spoon	Groundwater Depth (ft.)		
I.D./O.D.(in): 4.25/7.625	I.D./O.D. (in.): 1.375/2	Date	Time	Water Depth
Hammer Weight (lb.): -	Sampler Hmr Wt (lb): 140	8/1/22	0920	dry
Hammer Fall (in.): -	Sampler Hmr Fall (in): 30			Casing
Other: -	Other: Autohammer			Stab. Time
				0 min.

Depth (ft)	Casing Blows/Core Rate	Sample						Sample Description and Identification (Modified Burmister Procedure)	Remark	Field Test Data	Depth (ft.)	Stratum Description	Elev. (ft.)	
		No.	Depth (ft.)	Pen. (in)	Rec. (in)	Blows (per 6 in.)	SPT Value							
5		S-1	0-2	24	10	31 19 9 9	28	S-1: Medium dense, dark brown/brown, fine to coarse SAND and GRAVEL, some Silt, trace Asphalt, trace Organics.	1		0.5'	ASPHALT	98.5'	
		S-2	2-4	24	15	27 17 20 11	37	S-2: Dense, brown, fine to coarse SAND and GRAVEL, little Silt.				FILL		
		S-3	4-6	24	17	20 43 36 28	79	S-3: Very dense, olive-brown/gray, GRAVEL, some fine to coarse Sand, little Silt.				4'		95.0'
		S-4	10-10.3	3	3	50/6"	R	S-4: Very dense, brown, fine to coarse SAND and GRAVEL, some Silt.				10.5'		88.5'
Bottom of boring at 10.5 feet.														

REMARKS

1. Ground surface elevation estimated from Town of Andover GIS website.
2. Weathered rock observed at tip of split spoon sample.
3. Auger refusal observed at approximately 10.5 feet below ground surface (bgs) using up to 1200 psi of down pressure for 5 minutes with no advancement.
4. Upon completion borehole backfilled with soil cuttings to approximate ground surface.

See Log Key for explanation of sample description and identification procedures. Stratification lines represent approximate boundaries between soil and bedrock types. Actual transitions may be gradual. Water level readings have been made at the times and under the conditions stated. Fluctuations of groundwater may occur due to other factors than those present at the times the measurements were made.

Boring No.:
GZ-5

18.0175728.00 11 LEWIS ST ANDOVER MA.GPJ; STRATUM ONLY NORWOOD; 8/26/2022

TEST BORING LOG



GZA
GeoEnvironmental, Inc.
Engineers and Scientists

Buxton Redevelopment, LLC
Andover Town Yard Development
11 Lewis Street
Andover, Massachusetts

BORING NO.: GZ-6
SHEET: 1 of 1
PROJECT NO: 18.0175728.00
REVIEWED BY: LWP

Drilling Co.: Drilex Environmental, Inc.	Type of Rig: Truck	Boring Location: See Plan	H. Datum:
Foreman: Enzo Gravante	Rig Model: CME 75	Ground Surface Elev. (ft.): 93	V. Datum: NAVD88
Logged By: Anthony Lupo	Drilling Method: HSA	Final Boring Depth (ft.): 23	
		Date Start - Finish: 8/1/2022 - 8/1/2022	

Auger/Casing Type: HSA	Sampler Type: Split Spoon	Groundwater Depth (ft.)		
I.D./O.D.(in): 4.25/7.625	I.D./O.D. (in.): 1.375/2	Date	Time	Water Depth
Hammer Weight (lb.): -	Sampler Hmr Wt (lb): 140	Not	recorded	
Hammer Fall (in.): -	Sampler Hmr Fall (in): 30			
Other: -	Other: Autohammer			

Depth (ft)	Casing Blows/ Core Rate	Sample						Sample Description and Identification (Modified Burmister Procedure)	Remark	Field Test Data	Depth (ft.)	Stratum Description	Elev. (ft.)
		No.	Depth (ft.)	Pen. (in)	Rec. (in)	Blows (per 6 in.)	SPT Value						
5		S-1	0-2	24	8	5 2 2 4	4	S-1: Loose, dark brown/brown, fine to coarse SAND and GRAVEL, little Silt, trace Asphalt.	1		0.5'	ASPHALT	92.5'
		S-2	2-4	24	6	2 3 1 4	4	S-2: Loose, dark brown, GRAVEL and fine to coarse SAND, trace Silt.					
		S-3	4-6	24	18	4 5 8 9	13	S-3: Medium dense, dark brown/gray, fine SAND, little Silt, trace Gravel.	2 3			FILL	
10		S-4	10-12	24	15	2 4 6 7	10	S-4: Stiff, brown/gray, Clayey SILT, trace fine to coarse Sand.			8'		85.0'
15		S-5	15-17	24	20	16 37 24 18	61	S-5: Very dense, brown/white, fine to coarse SAND, little Gravel, little Clayey Silt.			14'		79.0'
20		S-6	20-22	24	24	8 9 12 39	21	S-6: Medium dense, gray, fine to coarse SAND and GRAVEL, some Clayey Silt.	4				
25		Bottom of boring at 23 feet.							5 6		23'		70.0'

REMARKS

1. Ground surface elevation estimated from Town of Andover GIS webiste.
2. Strong hydrocarbon like odor noted in sample S-3.
3. Wet soils observed beginning at approximately 5 feet below ground surface (bgs).
4. Increase in drill effort at approximately 18 feet bgs.
5. Auger refusal observed at approximately 23 feet bgs using up to 1200 psi of down pressure for 5 minutes with no advancement.
6. Upon completion borehole backfilled with soil cuttings to approximate ground surface.

See Log Key for explanation of sample description and identification procedures. Stratification lines represent approximate boundaries between soil and bedrock types. Actual transitions may be gradual. Water level readings have been made at the times and under the conditions stated. Fluctuations of groundwater may occur due to other factors than those present at the times the measurements were made.

Boring No.:
GZ-6

18.0175728.00 11 LEWIS ST ANDOVER MA.GPJ: STRATUM ONLY NORWOOD: 8/26/2022

TEST BORING LOG



GZA
GeoEnvironmental, Inc.
 Engineers and Scientists

Buxton Redevelopment, LLC
 Andover Town Yard Development
 11 Lewis Street
 Andover, Massachusetts

BORING NO.: GZ-8
 SHEET: 1 of 1
 PROJECT NO: 18.0175728.00
 REVIEWED BY: LWP

Drilling Co.: Drix Environmental, Inc.
 Foreman: Enzo Gravante
 Logged By: Anthony Lupo

Type of Rig: Truck
 Rig Model: CME 75
 Drilling Method: HSA

Boring Location: See Plan
 Ground Surface Elev. (ft.): 94
 Final Boring Depth (ft.): 28.5
 Date Start - Finish: 8/2/2022 - 8/2/2022

H. Datum:
 V. Datum: NAVD88

Auger/Casing Type: HSA
 I.D./O.D. (in.): 4.25/7.625
 Hammer Weight (lb.): -
 Hammer Fall (in.): -
 Other: -

Sampler Type: Split Spoon
 I.D./O.D. (in.): 1.375/2
 Sampler Hmr Wt (lb): 140
 Sampler Hmr Fall (in): 30
 Other: Autohammer

Groundwater Depth (ft.)				
Date	Time	Water Depth	Casing	Stab. Time
8/2/22	1410	21	28.5	0 min.

Depth (ft)	Casing Blows/ Core Rate	Sample						SPT Value	Sample Description and Identification (Modified Burmister Procedure)	Remark	Field Test Data	Depth (ft.)	Stratum Description	Elev. (ft.)
		No.	Depth (ft.)	Pen. (in)	Rec. (in)	Blows (per 6 in.)								
5		S-1	0-2	24	19	26 27 22 21	49	S-1: (Top 4") Dark brown, fine to coarse SAND and GRAVEL, trace Silt.	1		3'	91.0'	FILL	
		S-2	2-4	24	19	21 28 42 37	70	S-1: (Bottom 15") Brown/tan, fine to coarse SAND and GRAVEL, little Silt.						
		S-3	4-6	24	18	23 21 20 19	41	S-2: (Top 6") Dark brown, fine to coarse SAND and GRAVEL, trace Silt. S-2: (Bottom 13") Brown/tan, fine to coarse SAND and GRAVEL, little Silt. S-3: Dense, brown/tan, fine to coarse SAND and GRAVEL, little Silt.						
10		S-4	10-11.5	18	18	36 33 50/6"	R	S-4: Very dense, brown/gray, fine to coarse SAND, some Clayey Silt, little Gravel.	2 3					
		S-5	15-17	24	18	33 35 50 50	85	S-5: Very dense, brown/gray, fine to medium SAND, some Clayey Silt, little Gravel.						
20		S-6	20-21.5	18	15	25 41 50/6"	R	S-6: Very dense, brown/gray, fine to medium SAND, some Gravel, some Clayey Silt.						
		S-7	25-27	24	15	25 40 25 23	65	S-7: Very dense, dark gray, fine to medium SAND, some Clayey Silt, little Gravel.						
30		Bottom of boring at 28.5 feet.							4 5		28.5'	65.5'	GLACIAL TILL	

- REMARKS**
- Ground surface elevation estimated from Town of Andover GIS webiste.
 - Wet soils observed beginning at approximately 10 feet below ground surface (bgs). Groundwater depth measured at 1410 may not represent stabilized conditions.
 - Increase in drill effort on likely cobbles between 11.5 and 22 feet bgs.
 - Auger refusal observed at approximately 28.5 feet bgs using up to 1200 psi of down pressure for 5 minutes with no advancement.
 - Upon completion borehole backfilled with soil cuttings to approximate ground surface.

See Log Key for explanation of sample description and identification procedures. Stratification lines represent approximate boundaries between soil and bedrock types. Actual transitions may be gradual. Water level readings have been made at the times and under the conditions stated. Fluctuations of groundwater may occur due to other factors than those present at the times the measurements were made.

Boring No.:
GZ-8

18.0175728.00 11 LEWIS ST ANDOVER MA.GPJ - STRATUM ONLY NORWOOD - 8/26/2022

TEST BORING LOG



GZA
GeoEnvironmental, Inc.
Engineers and Scientists

Buxton Redevelopment, LLC
Andover Town Yard Development
11 Lewis Street
Andover, Massachusetts

BORING NO.: GZ-9
SHEET: 1 of 1
PROJECT NO: 18.0175728.00
REVIEWED BY: LWP

Drilling Co.: Drilex Environmental, Inc.
Foreman: Enzo Gravante
Logged By: Anthony Lupo

Type of Rig: Truck
Rig Model: CME 75
Drilling Method: HSA

Boring Location: See Plan
Ground Surface Elev. (ft.): 108
Final Boring Depth (ft.): 16
Date Start - Finish: 8/3/2022 - 8/3/2022

H. Datum:
V. Datum: NAVD88

Auger/Casing Type: HSA
I.D./O.D.(in): 4.25/7.625
Hammer Weight (lb.): -
Hammer Fall (in.): -
Other: -

Sampler Type: Split Spoon
I.D./O.D. (in.): 1.375/2
Sampler Hmr Wt (lb): 140
Sampler Hmr Fall (in): 30
Other: Autohammer

Groundwater Depth (ft.)				
Date	Time	Water Depth	Casing	Stab. Time
8/4/22	0715	dry	16	0 min.

Depth (ft)	Casing Blows/ Core Rate	Sample						SPT Value	Sample Description and Identification (Modified Burmister Procedure)	Remark	Field Test Data	Depth (ft.)	Stratum Description	Elev. (ft.)
		No.	Depth (ft.)	Pen. (in)	Rec. (in)	Blows (per 6 in.)								
5		S-1	0-2	24	9	1 2 3 2	5	S-1: Loose, dark-light brown, fine to medium SAND, little Gravel, little Silt, trace Brick, trace Organics.	1					
		S-2	2-4	24	5	4 2 3 7	5	S-2: Loose, dark-light brown, fine to coarse SAND, little Gravel, little Silt, trace Organics.						
5		S-3	4-6	24	22	21 30 18 11	48	S-3: Dense, brown, fine to medium SAND, some Silt, little Gravel.	2					
		S-4	6-8	24	22	36 17 17 15	34	S-4: Dense, brown, fine to medium SAND, some Silt, some Gravel.						
10		S-5	10-12	24	19	10 24 21 18	45	S-5: Dense, brown, fine to medium SAND, some Gravel, some Clayey Silt.	3					
15		S-6	15-15.5	6	6	50/6"	R	S-6: Very dense, brown, fine to medium SAND, some Gravel, some Clayey Silt.						
								Bottom of boring at 16 feet.	4					

- REMARKS**
1. Ground surface elevation estimated from Town of Andover GIS website.
 2. Increase in drill effort at approximately 6.5 feet and 9.5 feet below ground surface (bgs).
 3. Auger refusal observed at approximately 16 feet bgs using up to 1200 psi of down pressure for 5 minutes with no advancement.
 4. Upon completion borehole backfilled with soil cuttings to approximate ground surface.

See Log Key for explanation of sample description and identification procedures. Stratification lines represent approximate boundaries between soil and bedrock types. Actual transitions may be gradual. Water level readings have been made at the times and under the conditions stated. Fluctuations of groundwater may occur due to other factors than those present at the times the measurements were made.

Boring No.:
GZ-9

18.0175728.00 11 LEWIS ST ANDOVER MA.GPJ; STRATUM ONLY NORWOOD; 8/26/2022

TEST BORING LOG



GZA
GeoEnvironmental, Inc.
Engineers and Scientists

Buxton Redevelopment, LLC
Andover Town Yard Development
11 Lewis Street
Andover, Massachusetts

BORING NO.: GZ-10
SHEET: 1 of 1
PROJECT NO: 18.0175728.00
REVIEWED BY: LWP

Drilling Co.: Drilex Environmental, Inc. Foreman: Enzo Gravante Logged By: Anthony Lupo	Type of Rig: Truck Rig Model: CME 75 Drilling Method: HSA	Boring Location: See Plan Ground Surface Elev. (ft.): 103 Final Boring Depth (ft.): 23 Date Start - Finish: 8/3/2022 - 8/3/2022	H. Datum: V. Datum: NAVD88
--	--	--	---

Auger/Casing Type: HSA I.D./O.D. (in.): 4.25/7.625 Hammer Weight (lb.): - Hammer Fall (in.): - Other: -	Sampler Type: Split Spoon I.D./O.D. (in.): 1.375/2 Sampler Hmr Wt (lb): 140 Sampler Hmr Fall (in): 30 Other: Autohammer	Groundwater Depth (ft.) <table border="1" style="width: 100%; border-collapse: collapse; margin-top: 5px;"> <thead> <tr> <th>Date</th> <th>Time</th> <th>Water Depth</th> <th>Casing</th> <th>Stab. Time</th> </tr> </thead> <tbody> <tr> <td>8/3/22</td> <td>1320</td> <td>19.25</td> <td>23</td> <td>0 min.</td> </tr> <tr> <td> </td> <td> </td> <td> </td> <td> </td> <td> </td> </tr> <tr> <td> </td> <td> </td> <td> </td> <td> </td> <td> </td> </tr> </tbody> </table>	Date	Time	Water Depth	Casing	Stab. Time	8/3/22	1320	19.25	23	0 min.										
Date	Time	Water Depth	Casing	Stab. Time																		
8/3/22	1320	19.25	23	0 min.																		

Depth (ft)	Casing Blows/ Core Rate	Sample						Sample Description and Identification (Modified Burmister Procedure)	Remark	Field Test Data	Depth (ft.)	Stratum Description	Elev. (ft.)
		No.	Depth (ft.)	Pen. (in)	Rec. (in)	Blows (per 6 in.)	SPT Value						
5		S-1	0-2	24	10	9 11 13 11	24	S-1: Medium dense, dark brown/brown, fine to coarse SAND and GRAVEL, little Silt, trace Organics.	1				
		S-2	2-4	24	8	17 7 5 2	12	S-2: Medium dense, dark brown/brown, fine to coarse SAND and GRAVEL, little Silt, little Brick, trace Organics.				FILL	
		S-3	4-6	24	15	5 7 5 3	12	S-3: (Top 9") Brown, fine to coarse SAND, some Gravel, little Silt, little Brick.				5'	98.0'
		S-4	6-8	24	21	7 7 7 14	14	S-3: (Bottom 6") Brown/orange, fine to medium SAND, some Gravel, some Silt. S-4: Medium dense, brown, fine to medium SAND, some Silt, trace Gravel.				SAND	
		S-5	10-12	24	14	5 8 9 10	17	S-5: Medium dense, brown/dark brown/light brown, fine to coarse SAND and GRAVEL, trace Silt.				9'	94.0'
		S-6	15-17	24	17	12 18 15 19	33	S-6: Dense, brown/light brown, fine to coarse SAND and GRAVEL, some Clayey Silt.				SAND AND GRAVEL	
		S-7	20-22	18	12	28 20 50/6"	R	S-7: Very dense, brown/gray, fine to coarse SAND, some Clayey Silt, some Gravel.				13'	90.0'
									2		GLACIAL TILL		
									3				
											23'	80.0'	
								Bottom of boring at 23 feet.	4				
									5				

REMARKS

1. Ground surface elevation estimated from Town of Andover GIS website.
2. Wet soils observed beginning at approximately 17 feet below ground surface (bgs). Groundwater depth measured at 1320 hours may not represent stabilized conditions.
3. Increase in drill effort at approximately 18 feet bgs.
4. Auger refusal observed at approximately 23 feet bgs using up to 1200 psi of down pressure for 5 minutes with no advancement.
5. Upon completion borehole backfilled with soil cuttings to approximate ground surface.

See Log Key for explanation of sample description and identification procedures. Stratification lines represent approximate boundaries between soil and bedrock types. Actual transitions may be gradual. Water level readings have been made at the times and under the conditions stated. Fluctuations of groundwater may occur due to other factors than those present at the times the measurements were made.

Boring No.:
GZ-10

18.0175728.00 11 LEWIS ST. ANDOVER MA, GPJ- STRATUM ONLY NORWOOD. 8/26/2022

**APPENDIX I:
MANUFACTURER
BROCHURES**

Jellyfish[®] Filter

Stormwater Treatment



The experts you need to solve your stormwater challenges



Contech is the leader in stormwater solutions, helping engineers, contractors and owners with infrastructure and land development projects throughout North America.

With our responsive team of stormwater experts, local regulatory expertise and flexible solutions, Contech is the trusted partner you can count on for stormwater management solutions.

Your Contech Team



STORMWATER CONSULTANT

It's my job to recommend the best solution to meet permitting requirements.



STORMWATER DESIGN ENGINEER

I work with consultants to design the best approved solution to meet your project's needs.



REGULATORY MANAGER

I understand the local stormwater regulations and what solutions will be approved.



SALES ENGINEER

I make sure our solutions meet the needs of the contractor during construction.

Contech is your partner in stormwater management solutions



Setting new standards in Stormwater Treatment – Jellyfish® Filter

The Jellyfish Filter has been tested in the field and laboratory, and has received approval from numerous stormwater regulatory agencies.

The Jellyfish Filter is a stormwater quality treatment technology featuring high flow pretreatment and membrane filtration in a compact stand-alone system. Jellyfish removes floatables, trash, oil, debris, TSS, fine silt-sized particles, and a high percentage of particulate-bound pollutants; including phosphorus, nitrogen, metals, and hydrocarbons. The high surface area membrane cartridges, combined with up-flow hydraulics, frequent, passive backwashing, and rinseable/reusable cartridges ensure long-lasting performance.

Jellyfish® Filter

How the Jellyfish® Filter Treats Stormwater

Tested in the field and laboratory ...

- Water enters the vault via an inlet bay where floating pollutants, oil, and grease are trapped behind a baffle wall.
- Water flows through the inlet bay transfer opening into the treatment chamber.
- Water is forced up from the treatment chamber, through the membrane filtration, and into the backwash pool.
- The water then fills and overflows the backwash pool and exits via the outlet bay transfer opening.
- As each storm subsides, the remaining water caught in the backwash pool flows back into the treatment chamber through the cartridges.
- This passive backwash extends cartridge life and prepares them for the next storm event. The draindown cartridges located outside the backwash pool enables water levels to balance.
- During peak flows, the internal weir allows high flows to bypass treatment, eliminating the need for an external bypass structure.

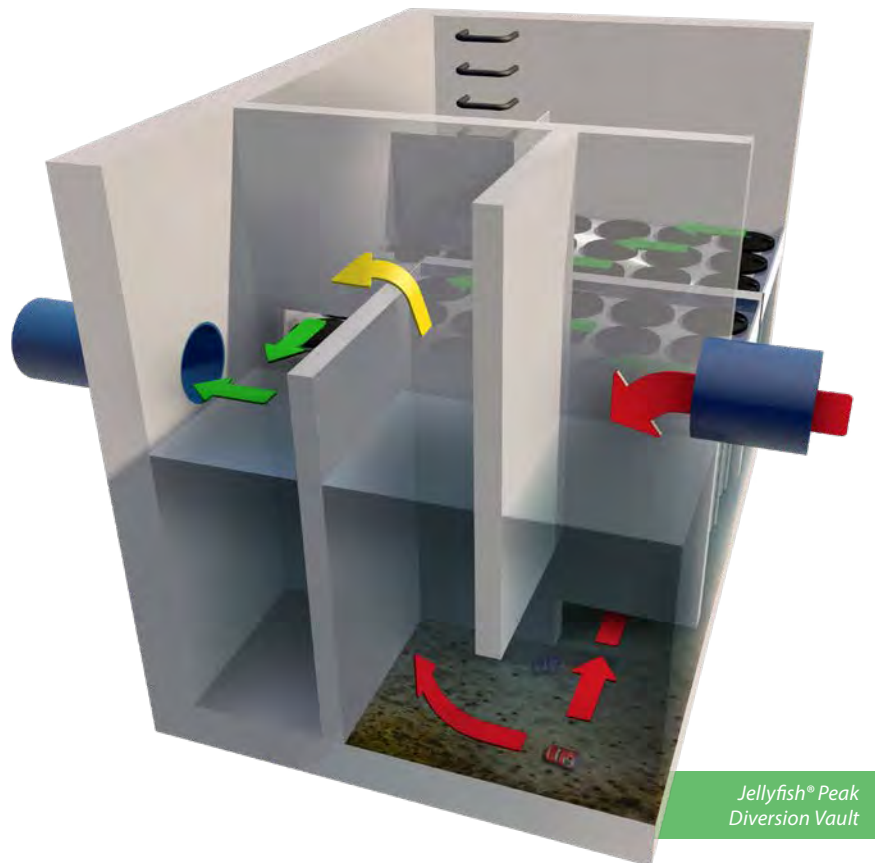

Learn More:
www.ContechES.com/jellyfish

Jellyfish® Filter Performance Testing Results

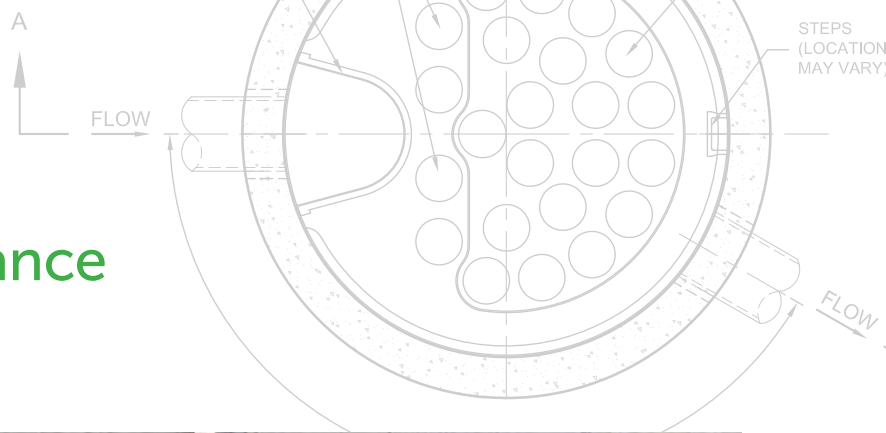

APPLICATION TIPS

- The Peak Diversion Jellyfish provides treatment and high-flow bypass in one structure, eliminating the need for a separate bypass structure.
- LID and GI are complemented by filtration solutions, as they help keep sites free from fine sediments that can impede performance, remove unsightly trash, and provide a single point of maintenance.
- Selecting a filter with a long maintenance cycle and low maintenance cost will result in healthy waterways and happy property owners.



The pleated tentacles of the Jellyfish® Filter provide a large surface area for pollutant removal.

POLLUTANT OF CONCERN	% REMOVAL
Total Suspended Solids (TSS)	85%
Total Phosphorus (TP)	75%
Total Copper (TCu)	67%
Total Zinc (TZn)	60%



Sources:
 WA DOE TAPE Testing: https://fortress.wa.gov/ecy/ezshare/wq/tape/use_designations/JELLYFISHfilterIMBRIUMguld.pdf

Jellyfish[®] Filter Features and Benefits

FEATURE	BENEFITS
High surface area membrane filtration	Low flux rate promotes cake filtration and slows membrane occlusion
High design treatment flow rate per cartridge (up to 80 gpm (5 L/s))	Compact system with a small footprint, lower construction cost
Low driving head (typically 18-21 inches or less (457-533 mm))	Design flexibility, lower construction cost
Lightweight cartridges with passive backwash	Easy maintenance and low life-cycle cost



The Jellyfish Filter can be configured in a manhole, catch basin, or vault.

Select Jellyfish[®] Filter Certifications and Verifications

The Jellyfish Filter has been reviewed by numerous state and federal programs, including:

- New Jersey Corporation for Advanced Technology (NJCAT) – Field Performance per TARP Tier II Protocol
- Washington State Department of Ecology (TAPE – GULD)
- Maryland Department of the Environment (MD DOE)
- Canada ISO 14034 Environmental Management - Environmental Technology Verification (ETV)
- Texas Commission on Environmental Quality (TCEQ)
- Virginia Department of Environmental Quality (VA DEQ)



Field tested and performance verified

Jellyfish[®] Filter Configurations

Multiple system configurations to optimize your site

The Jellyfish Filter can be manufactured in a variety of configurations: manhole, catch basin, vault, or custom configurations. Typically, 18-21 inches (457-533 mm) of driving head is designed into the system.

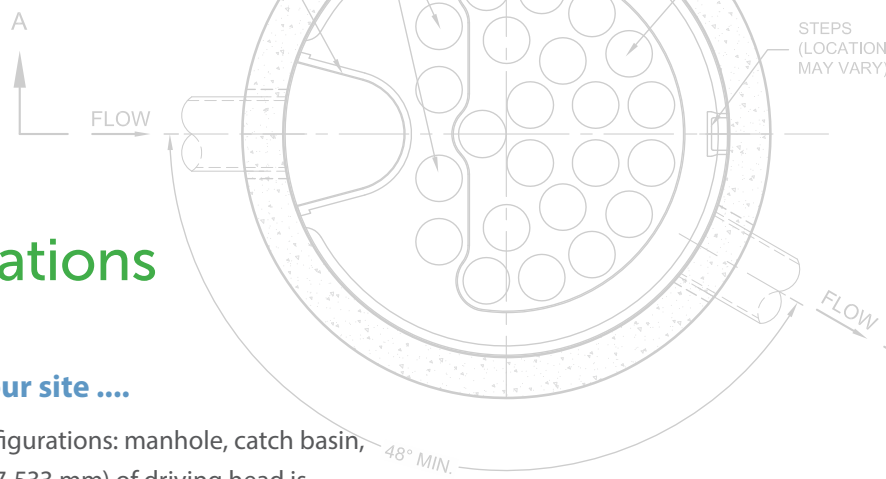

Manhole

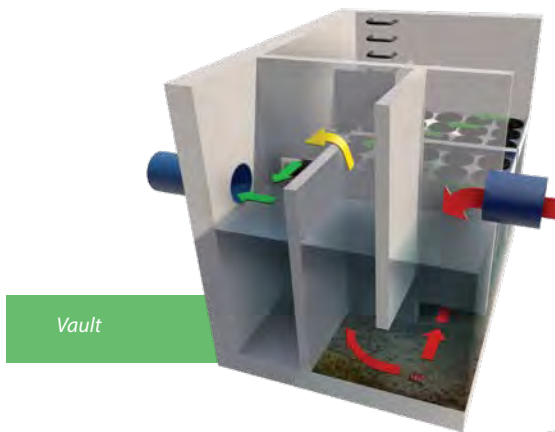

Vault

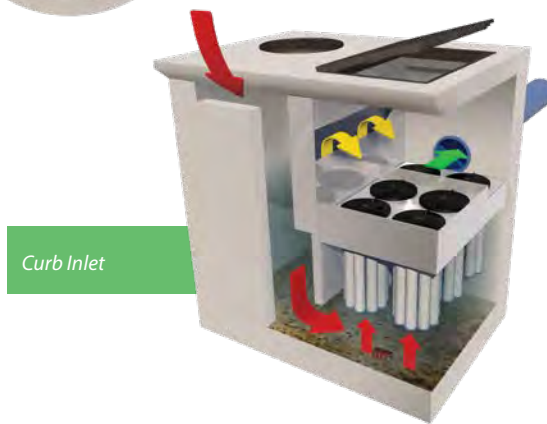

Curb Inlet

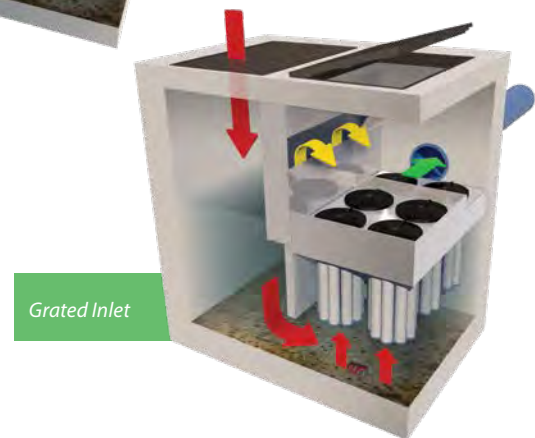

Grated Inlet

Jellyfish[®] Filter Maintenance

- Jellyfish Filter cartridges are light weight and reusable
- Maintenance of the filter cartridges is performed by removing, rinsing and reusing the cartridge tentacles.
- Vacuum extraction of captured pollutants in the sump is recommended at the same time.
- Full cartridge replacement intervals differ by site due to varying pollutant loading and type, and maintenance frequency. Replacement is anticipated every 2-5 years.
- Contech[®] has created a network of Certified Maintenance Providers to provide maintenance on stormwater BMPs.



The Jellyfish[®] Filter tentacle is light and easy to clean.

A partner you can rely on

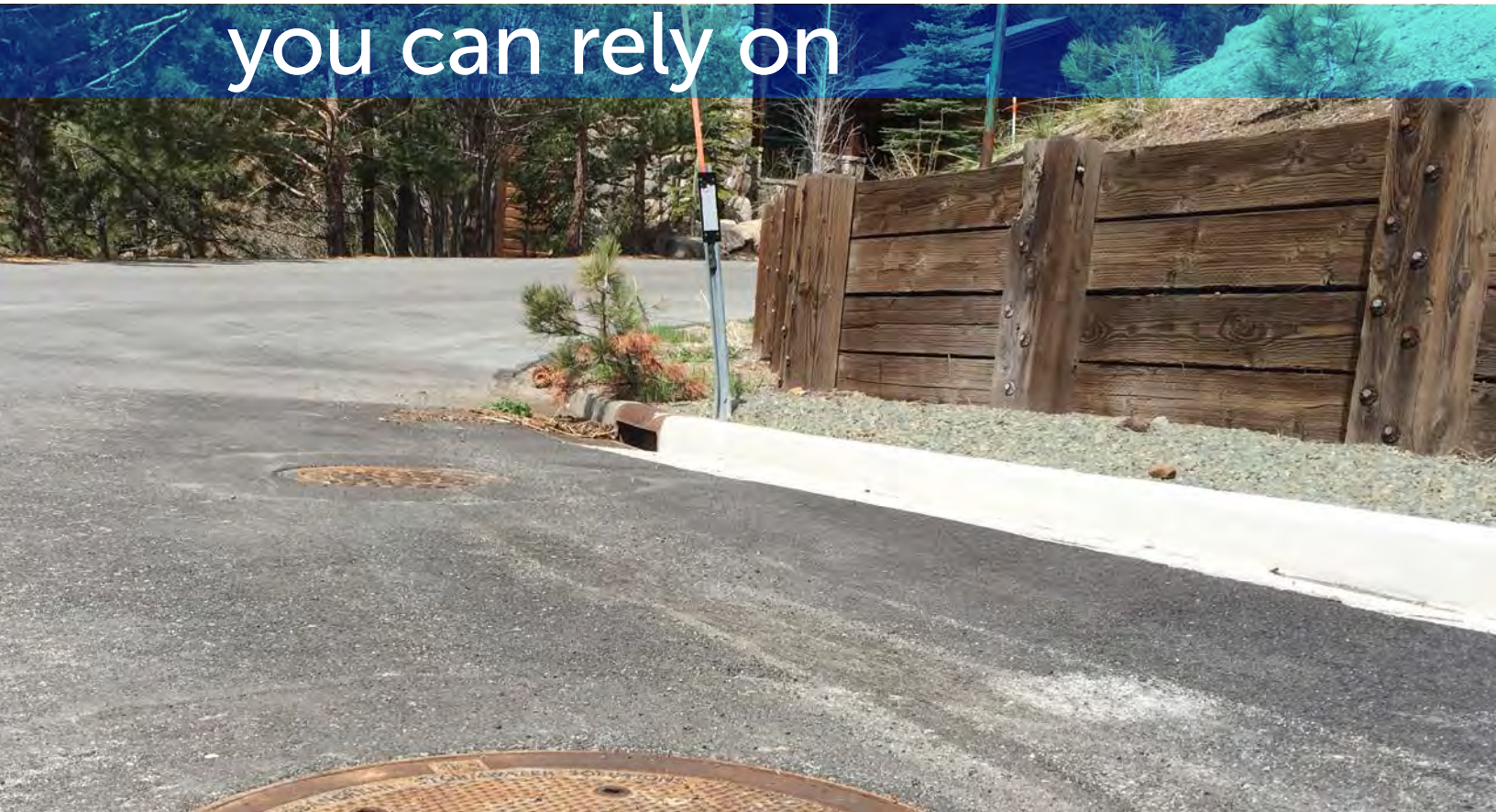

STORMWATER
SOLUTIONS



PIPE
SOLUTIONS



STRUCTURES
SOLUTIONS

Few companies offer the wide range of high-quality stormwater resources you can find with us — state-of-the-art products, decades of expertise, and all the maintenance support you need to operate your system cost-effectively.

THE CONTECH WAY

Contech® Engineered Solutions provides innovative, cost-effective site solutions to engineers, contractors, and developers on projects across North America. Our portfolio includes bridges, drainage, erosion control, retaining wall, sanitary sewer and stormwater management products.

TAKE THE NEXT STEP

For more information: www.ContechES.com

NOTHING IN THIS CATALOG SHOULD BE CONSTRUED AS A WARRANTY. APPLICATIONS SUGGESTED HEREIN ARE DESCRIBED ONLY TO HELP READERS MAKE THEIR OWN EVALUATIONS AND DECISIONS, AND ARE NEITHER GUARANTEES NOR WARRANTIES OF SUITABILITY FOR ANY APPLICATION. CONTECH MAKES NO WARRANTY WHATSOEVER, EXPRESS OR IMPLIED, RELATED TO THE APPLICATIONS, MATERIALS, COATINGS, OR PRODUCTS DISCUSSED HEREIN. ALL IMPLIED WARRANTIES OF MERCHANTABILITY AND ALL IMPLIED WARRANTIES OF FITNESS FOR ANY PARTICULAR PURPOSE ARE DISCLAIMED BY CONTECH. SEE CONTECH'S CONDITIONS OF SALE (AVAILABLE AT WWW.CONTECHES.COM/COS) FOR MORE INFORMATION.

CONTECH[®]
ENGINEERED SOLUTIONS

Get social with us:    
800-338-1122 | www.ContechES.com



CULTEC Recharger® 360HD Stormwater Chamber

The Recharger® 360HD is a 36" (914 mm) tall, high capacity chamber. Typically when using this model, fewer chambers are required resulting in less labor and a smaller installation area. The Recharger® 360HD has the side portal internal manifold feature. HVLV® FC-48 Feed Connectors are inserted into the side portals to create the internal manifold.

Recharger 360HD Chamber	
Size (L x W x H)	4.17' x 60" x 36"
	1.27 m x 1525 mm x 914 mm
Installed Length	3.67'
	1.12 m
Length Adjustment per Row - with two end caps installed	2.5'
	0.76 m
Length Adjustment per Row - when not using end caps	0.5'
	0.15 m
Chamber Storage	10.00 ft ³ /ft
	0.929 m ³ /m
	36.66 ft ³ /unit
	1.038 m ³ /unit
Min. Installed Storage	15.199 ft ³ /ft
	1.412 m ³ /m
	55.73 ft ³ /unit
	1.58 m ³ /unit
Min. Area Required	21.08 ft ²
	1.96 m ²
Chamber Weight	57.0 lbs
	25.85 kg
Shipping	20 chambers/skid
	1,265 lbs/skid
	11 skids/48' flatbed
Min. Center-to-Center Spacing	5.75'
	1.75 m
Max. Allowable Cover	12'
	3.66 m
Max. Allowable O.D. in Side Portal	10" HDPE, 12" PVC
	250 mm HDPE, 300 mm PVC
Compatible Feed Connector	HVLV FC-48 Feed Connector

Calculations are based on installed chamber length.
 All above values are nominal.
 Min. installed storage includes 6" (152 mm) stone base, 6" (152 mm) stone above crown of chamber and typical stone surround at 5.75 (1.75 m) center-to-center spacing.

	Stone Foundation Depth		
	6"	12"	18"
	152 mm	305 mm	457 mm
Chamber and Stone Storage Per Chamber	55.73 ft ³	59.95 ft ³	64.17 ft ³
	1.58 m ³	1.70 m ³	1.82 m ³
Min. Effective Depth	4.00'	4.50'	5.0'
	1.22 m	1.37 m	1.52 m
Stone Required Per Chamber	1.77 yd ³	2.16 yd ³	2.55 yd ³
	1.35 m ³	1.65 m ³	1.95 m ³

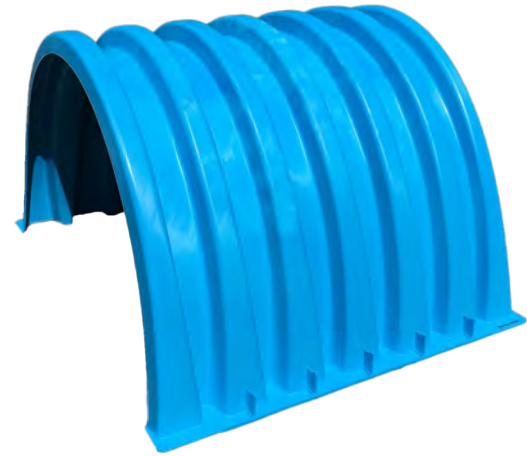

Recharger 360HD Chamber



Recharger 360HD End Cap

Recharger 360HD End Cap	
Size (L x W x H)	18" x 60" x 36.5"
	458 mm x 1525 mm x 927 mm
Installed Length	15"
	381 mm
End Cap Storage	5.17 ft ³ /ft
	0.48 m ³ /m
	6.46 ft ³ /unit (interlocked)
Min. Installed Storage	0.183 m ³ /unit (interlocked)
	12.40 ft ³ /ft
	1.15 m ³ /m
	15.50 ft ³ /unit
End Cap Weight	0.44 m ³ /unit
	22.0 lbs
Shipping	9.98 kg
	20 end caps/skid
	565 lbs/skid
Max. Inlet Opening in End Cap	11 skids/48' flatbed
	24" HDPE, 30" PVC
	600 mm HDPE, 750 mm PVC

Calculations are based on installed chamber length.
 Includes 6" (305 mm) stone above crown of chamber and typical stone surround at 5.75' (1.75 m) center-to-center spacing and stone foundation as listed in table.
 Stone void calculated at 40%.

For more information, contact CULTEC at (203) 775-4416 or visit www.cultec.com.



Three View Drawing

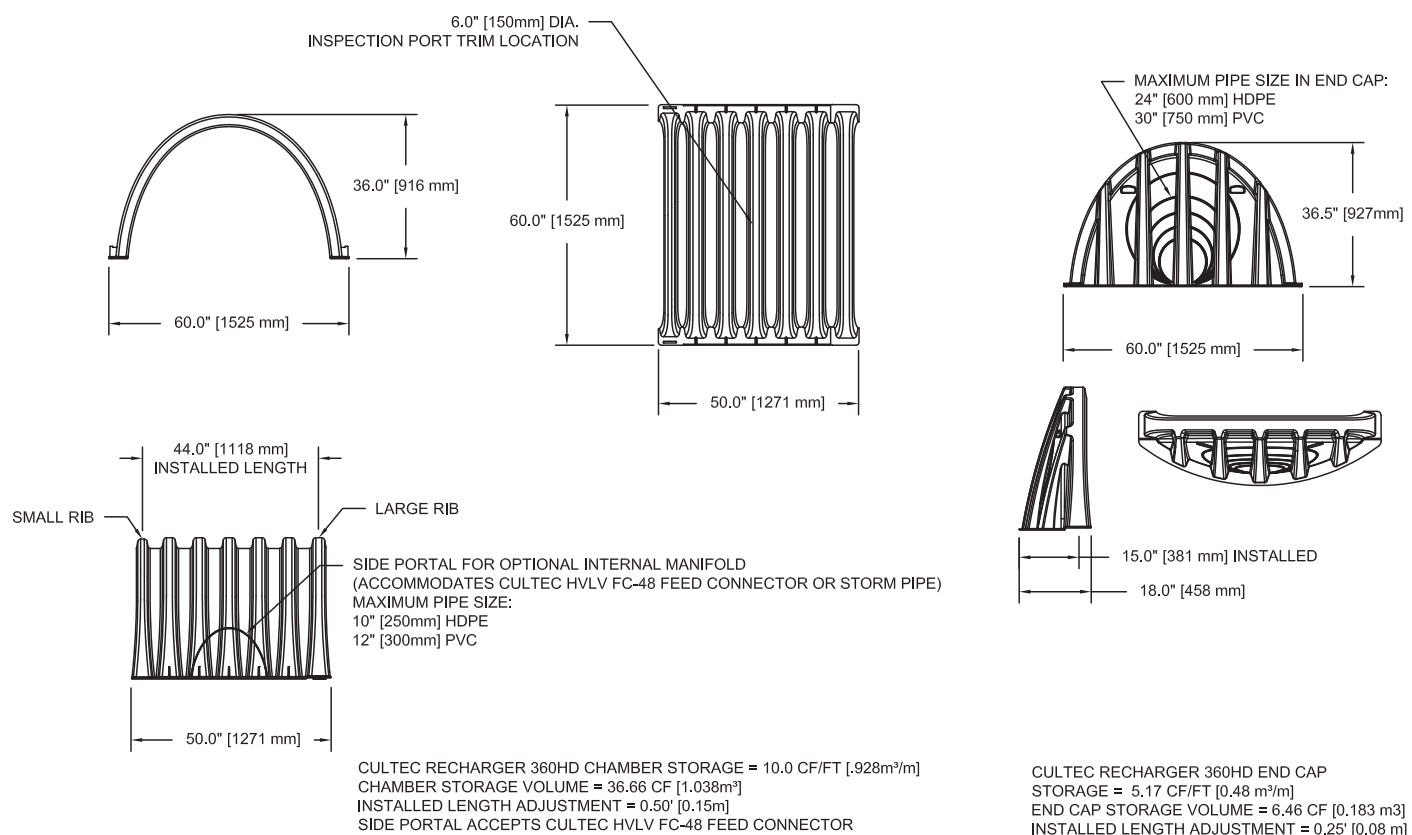

Recharger 360HD Chamber

Recharger 360HD End Cap

Typical Interlock Installation

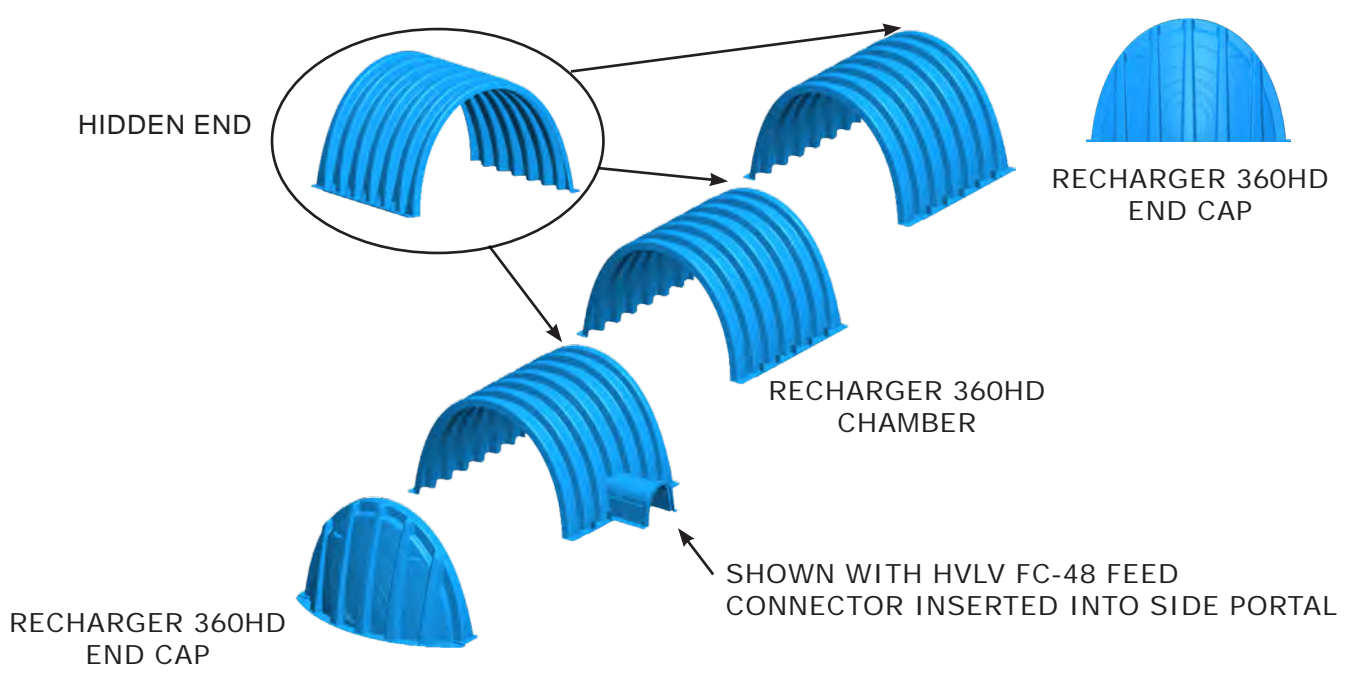

For more information, contact CULTEC at (203) 775-4416 or visit www.cultec.com.

Plan View Drawing

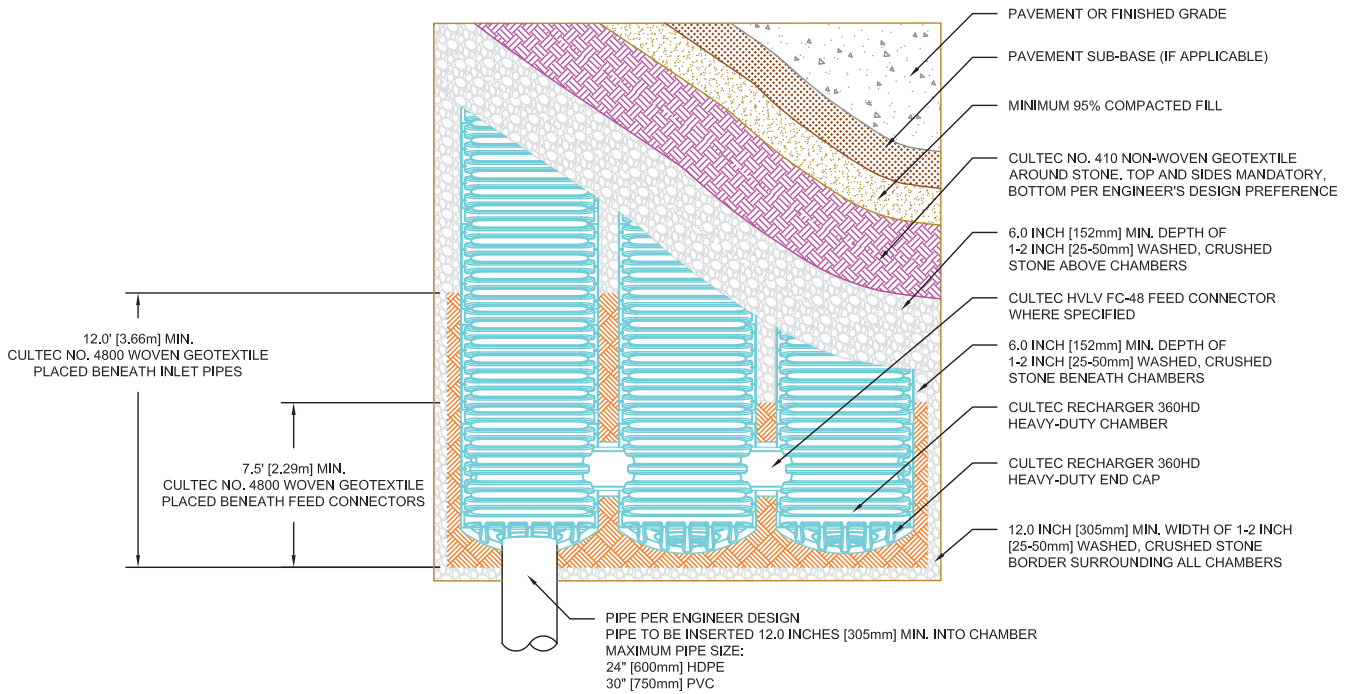

Typical Cross Section for Traffic Application

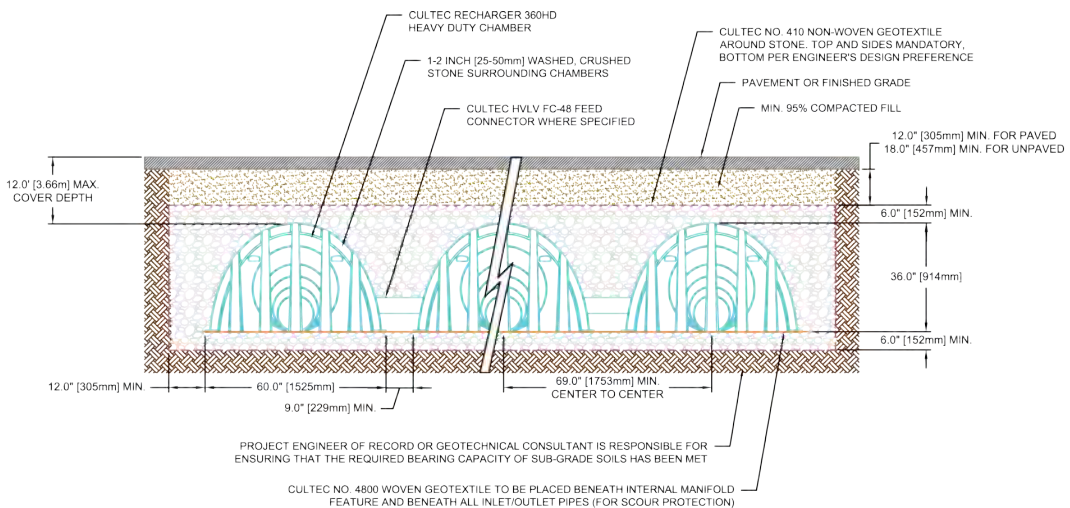

NOTES:

1. THE CHAMBERS SHALL BE DESIGNED AND TESTED IN ACCORDANCE WITH ASTM F2787 "STANDARD PRACTICE FOR STRUCTURAL DESIGN OF THERMOPLASTIC CORRUGATED WALL STORMWATER COLLECTION CHAMBERS." THE LOAD CONFIGURATION SHALL INCLUDE:
 - 1.a. INSTANTANEOUS AASHTO DESIGN TRUCK LIVE LOAD AT MINIMUM COVER
 - 1.b. MAXIMUM PERMANENT (50-YEAR) COVER LOAD
 - 1.c. 1-WEEK PARKED AASHTO DESIGN TRUCK LOAD
2. THE CHAMBERS SHALL MEET THE REQUIREMENTS OF ASTM F3430-20 "STANDARD SPECIFICATION FOR CELLULAR POLYPROPYLENE (PP) CORRUGATED WALL STORMWATER COLLECTION CHAMBERS" ACCORDING TO CULTEC'S RECOMMENDED INSTALLATION INSTRUCTIONS. THE STRUCTURAL DESIGN OF THE CHAMBERS SHALL INCLUDE THE FOLLOWING:
 - 3.a. THE CREEP MODULUS SHALL BE 50-YEAR AS SPECIFIED IN ASTM F3430
 - 3.b. THE MINIMUM SAFETY FACTOR FOR LIVE LOADS SHALL BE 1.75
 - 3.c. THE MINIMUM SAFETY FACTOR FOR DEAD LOADS SHALL BE 1.95

For more information, contact CULTEC at (203) 775-4416 or visit www.cultec.com.



CULTEC Recharger® 360HD Stormwater Chamber

Recharger® 360HD Bare Chamber Storage Volumes

Elevation		Incremental Storage Volume				Cumulative Storage	
in.	mm	ft³/ft	m³/m	ft³	m³	ft³	m³
36	914	0.022	0.002	0.08	0.002	3.3658	1.038
35	889	0.046	0.004	0.17	0.005	36.577	1.036
34	864	0.069	0.006	0.25	0.007	36.407	1.031
33	838	0.117	0.011	0.43	0.012	36.154	1.024
32	813	0.148	0.014	0.54	0.015	35.726	1.012
31	787	0.171	0.016	0.63	0.018	35.185	0.996
30	762	0.190	0.018	0.70	0.020	34.560	0.979
29	737	0.206	0.019	0.76	0.021	33.864	0.959
28	711	0.221	0.021	0.81	0.023	33.108	0.938
27	686	0.234	0.022	0.86	0.024	32.298	0.915
26	660	0.246	0.023	0.90	0.026	31.441	0.890
25	635	0.257	0.024	0.94	0.027	30.539	0.865
24	609	0.267	0.025	0.98	0.028	29.598	0.838
23	584	0.276	0.026	1.01	0.029	28.620	0.811
22	559	0.284	0.026	1.04	0.030	27.608	0.782
21	533	0.292	0.027	1.07	0.031	26.565	0.752
20	508	0.300	0.028	1.10	0.032	25.493	0.722
19	483	0.307	0.028	1.12	0.033	24.394	0.691
18	457	0.313	0.029	1.15	0.033	23.239	0.659
17	432	0.319	0.030	1.17	0.033	22.121	0.626
16	406	0.325	0.030	1.19	0.034	20.950	0.593
15	381	0.331	0.031	1.21	0.034	19.757	0.560
14	356	0.336	0.031	1.23	0.035	18.545	0.525
13	330	0.341	0.032	1.25	0.035	17.313	0.490
12	305	0.345	0.032	1.27	0.036	16.064	0.455
11	279	0.350	0.032	1.28	0.036	14.798	0.419
10	254	0.354	0.033	1.30	0.037	13.516	0.383
9	229	0.358	0.033	1.31	0.037	12.219	0.346
8	203	0.361	0.034	1.32	0.038	10.908	0.309
7	178	0.365	0.034	1.34	0.038	9.584	0.271
6	152	0.368	0.034	1.35	0.038	8.247	0.234
5	127	0.371	0.034	1.36	0.039	6.898	0.195
4	102	0.374	0.035	1.37	0.039	5.538	0.157
3	76	0.376	0.035	1.38	0.039	4.168	0.118
2	51	0.379	0.035	1.39	0.039	2.787	0.079
1	25	0.381	0.035	1.40	0.040	1.398	0.040
Total		9.998	0.929	36.66	1.038	36.658	1.038

Calculations are based on installed chamber length of 3.67' (1.12 m).

Recharger® 360HD Bare End Cap Storage Volumes

Elevation		Incremental Storage Volume				Cumulative Storage	
in.	mm	ft³/ft	m³/m	ft³	m³	ft³	m³
36	914	0.008	0.0007	0.01	0.000	6.460	0.183
35	889	0.016	0.0015	0.02	0.001	6.450	0.183
34	864	0.024	0.0022	0.03	0.001	6.430	0.182
33	838	0.032	0.0030	0.04	0.001	6.400	0.181
32	813	0.040	0.0037	0.05	0.001	6.360	0.180
31	787	0.048	0.0045	0.06	0.002	6.310	0.179
30	762	0.056	0.0052	0.07	0.002	6.250	0.177
29	737	0.064	0.0059	0.08	0.002	6.180	0.175
28	711	0.072	0.0067	0.09	0.003	6.100	0.173
27	686	0.080	0.0074	0.10	0.003	6.010	0.170
26	660	0.088	0.0082	0.11	0.003	5.910	0.167
25	635	0.096	0.0089	0.12	0.003	5.800	0.164
24	609	0.112	0.0104	0.14	0.004	5.680	0.161
23	584	0.120	0.0111	0.15	0.004	5.540	0.157
22	559	0.128	0.0119	0.16	0.005	5.390	0.153
21	533	0.136	0.0126	0.17	0.005	5.230	0.148
20	508	0.144	0.0134	0.18	0.005	5.060	0.143
19	483	0.152	0.0141	0.19	0.005	4.880	0.138
18	457	0.160	0.0149	0.20	0.006	4.690	0.133
17	432	0.160	0.0149	0.20	0.006	4.490	0.127
16	406	0.168	0.0156	0.21	0.006	4.290	0.121
15	381	0.176	0.0164	0.22	0.006	4.080	0.116
14	356	0.184	0.0171	0.23	0.007	3.860	0.109
13	330	0.192	0.0178	0.24	0.007	3.630	0.103
12	305	0.192	0.0178	0.24	0.007	3.390	0.096
11	279	0.200	0.0186	0.25	0.007	3.150	0.089
10	254	0.208	0.0193	0.26	0.007	2.900	0.082
9	229	0.208	0.0193	0.26	0.007	2.640	0.075
8	203	0.216	0.0201	0.27	0.008	2.380	0.067
7	178	0.224	0.0208	0.28	0.008	2.110	0.060
6	152	0.232	0.0216	0.29	0.008	1.830	0.052
5	127	0.232	0.0216	0.29	0.008	1.540	0.044
4	102	0.240	0.0223	0.30	0.008	1.250	0.035
3	76	0.240	0.0223	0.30	0.008	0.950	0.027
2	51	0.248	0.0230	0.31	0.009	0.650	0.018
1	25	0.272	0.0253	0.34	0.010	0.340	0.010
Total		5.168	0.480	6.46	0.183	6.460	0.183

Calculations are based on installed end cap length of 15" (381 mm).



CULTEC Recharger® 360HD Specifications

GENERAL

CULTEC Recharger® 360HD chambers are designed for underground stormwater management. The chambers may be used for retention, recharging, detention or controlling the flow of on-site stormwater runoff.

CHAMBER PARAMETERS

1. The chambers shall be manufactured in the U.S.A. or Canada by CULTEC, Inc. of Brookfield, CT (cultec.com, 203-775-4416).
2. The chambers shall be designed and tested in accordance with ASTM F2787 "Standard Practice for Structural Design of Thermoplastic Corrugated Wall Stormwater Collection Chambers". The load configuration shall include:
 - a. Instantaneous AASHTO Design Truck live load at minimum cover
 - b. Maximum permanent (50-year) cover load
 - c. 1-week parked AASHTO design truck load
3. The chambers shall meet the requirements of ASTM F3430-20 "Standard Specification for Cellular Polypropylene (PP) Corrugated Wall Stormwater Collection Chambers".
4. The installed chamber system shall provide resistance to the loads and load factors as defined in the AASHTO LRFD Bridge Design Specifications Section 12.12, when installed according to CULTEC's recommended installation instructions. The structural design of the chambers shall include the following:
 - a. The Creep Modulus shall be 50-year as specified in ASTM F3430
 - b. The minimum safety factor for live loads shall be 1.75
 - c. The minimum safety factor for dead loads shall be 1.95
5. The chamber shall be structural foam injection molded of blue virgin high molecular weight impact-modified polypropylene.
6. The chamber shall be arched in shape.
7. The chamber shall be open-bottomed.
8. The chamber shall be joined using an interlocking overlapping rib method. Connections must be fully shouldered overlapping ribs, having no separate couplings.
9. The nominal chamber dimensions of the CULTEC Recharger® 360HD shall be 36 inches (915 mm) tall, 60 inches (1525 mm) wide and 50 inches (1275 mm) long. The installed length of a joined Recharger 360HD shall be 3.67 feet (1.12 m).
10. Multiple chambers may be connected to form different length rows. Each row shall begin and end with a separately formed CULTEC Recharger® 360HD End Cap. Maximum inlet opening on the end cap is 24 inches (600 mm) HDPE or 30 inches (750 mm) PVC.
11. The chamber shall have two side portals to accept CULTEC HVLV™ FC-48 Feed Connectors to create an internal manifold. Maximum allowable pipe size in the side portal is 10 inches (250 mm) HDPE or 12 inches (300 mm) PVC.
12. The nominal chamber dimensions of the CULTEC HVLV™ FC-48 Feed Connector shall be 12 inches (305 mm) tall, 16 inches (406 mm) wide and 49 inches (1245 mm) long.
13. The nominal storage volume of the Recharger 360HD chamber shall be 10.0 ft³ / ft (0.928 m³ / m) - without stone. The nominal storage volume of a joined Recharger 360HD shall be 36.66 ft³ / unit (1.038 m³ / unit) - without stone.
14. The nominal storage volume of the HVLV™ FC-48 Feed Connector shall be 0.913 ft³ / ft (0.085 m³ / m) - without stone.
15. The Recharger 360HD chamber shall have 7 corrugations.
16. The chamber shall be manufactured in a facility employing CULTEC's Quality Control and Assurance Procedures.
17. Maximum allowable cover over the top of the chamber shall be 12 feet (3.66 m).

END CAP PARAMETERS

1. The CULTEC Recharger® 360HD End Cap (referred to as 'end cap') shall be manufactured in the U.S.A. or Canada by CULTEC, Inc. of Brookfield, CT (cultec.com, 203-775-4416).
2. The end cap shall be structural foam injection molded of blue virgin high molecular weight impact-modified polypropylene.
3. The end cap shall be arched in shape.
4. The end cap shall be open-bottomed.
5. The end cap shall be joined at the beginning and end of each row of chambers using an interlocking overlapping rib method. Connections must be fully shouldered overlapping ribs, having no separate couplings.
6. The end cap shall have 5 corrugations.
7. The nominal dimensions of the end cap shall be 36.5 inches (927 mm) tall, 60 inches (1525 mm) wide and 18 inches (458 mm) long. When joined with a Recharger 360HD Chamber, the installed length of the end cap shall be 15 inches (381 mm).
8. The nominal storage volume of the end cap shall be 5.17 ft³ / ft (0.48 m³ / m) - without stone. The nominal storage volume of an interlocked end cap shall be 6.46 ft³ / unit (0.183 m³ / unit) - without stone.
9. Maximum inlet opening on the end cap is 24 inches (600 mm) HDPE or 30 inches (750 mm) PVC.
10. The end cap shall be manufactured in a facility employing CULTEC's Quality Control and Assurance Procedures.
11. The end cap shall provide resistance to the loads and load factors as defined in the AASHTO LRFD Bridge Design Specifications Section 12.12.

For more information, contact CULTEC at (203) 775-4416 or visit www.cultec.com.

**APPENDIX I:
REFERENCES AND SOURCES**

References and Sources:

- Massachusetts Stormwater Handbook and Stormwater Standards, February 2008
- Federal Highway Administration, Hydraulic Engineering Circular No. 14, Third Edition (HEC-14), Hydraulic Design for Culverts and Channels, Publication No. FHWA-NHI-06-086, July 2006
- Town of Andover Zoning Bylaw, Recodified March 21, 2023
- Town of Andover GIS database,
<https://mimap.mvpc.org/map/index.html?viewer=andover>
- United States Department of Agriculture, Natural Resources Conservation Service, Web Soil Survey