

April 16, 2024
Revised July 30, 2024
Revised August 27, 2024

Long-Term Pollution Prevention Plan and Stormwater Operation and Maintenance Plan

P&G Andover Manufacturing Center Enhancement Project
30 Burtt Road
Andover, MA 01810

Prepared for:

Fennick McCredie Architecture
70 Franklin Street
Boston, MA

Prepared by:

Nitsch Engineering
2 Center Plaza, Suite 430
Boston, MA 02108

Nitsch Project #15363



Civil Engineering



Transportation
Engineering



Structural
Engineering



Resilience & Green
Infrastructure



Planning



Land Surveying



TABLE OF CONTENTS

SECTION 1 INTRODUCTION	1
SECTION 2 LONG-TERM POLLUTION PREVENTION PLAN	2
Storage of Hazardous Materials	2
Storage of Waste Products.....	2
Spill Prevention and Response	2
Minimize Soil Erosion	2
Management of Deicing Chemicals and Snow.....	2
Coordination with other Permits and Requirements.....	3
SECTION 3 STORMWATER MANAGEMENT SYSTEM OPERATION AND MAINTENANCE PLAN.....	4
Introduction	4
Stormwater Operation and Maintenance Requirements	4
Repair of the Stormwater Management System	5
Estimated Operations and Maintenance Budget.....	6
Reporting	6
STORMWATER MANAGEMENT SYSTEM INSPECTION FORM	7
FIGURES	
<i>Stormwater Management System Location Map</i>	
<i>Snow Storage Map</i>	
<i>Rain Guardian Maintenance Guide</i>	
<i>Stormceptor Maintenance Guide</i>	



SECTION 1 Introduction

The purpose of this document is to specify the pollution prevention measures and stormwater management system operation and maintenance for the Principio Validation site. The Responsible Party indicated below shall implement the management practices outlined in this document and proactively conduct operations at the project site in an environmentally responsible manner. Compliance with this Manual does not in any way dismiss the responsible party, owner, property manager, or occupants from compliance with other applicable federal, state or local laws.

Responsible Party: Keith Richardson
Andover Site Environmental and Sustainability Leader
30 Burt Road, Andover, MA 01810
(978)749-5358

This Document has been prepared in compliance with Standards 4 and 9 of the 2008 Massachusetts Department of Environmental Protection (MassDEP) Stormwater Management Standards, which state:

Standard 4

The Long-Term Pollution Prevention Plan shall include the proper procedures for the following:

1. Good housekeeping;
2. Storing materials and waste products inside or under cover;
3. Vehicle washing;
4. Routine inspections of stormwater best management practices;
5. Spill prevention and response;
6. Maintenance of lawns, gardens, and other landscaped areas;
7. Storage and use of fertilizers, herbicides, and pesticides;
8. Pet waste management;
9. Operation and management of septic systems; and
10. Proper management of deicing chemicals and snow.

Standard 9

The Long-Term Operation and Maintenance Plan shall at a minimum include:

1. Stormwater management system(s) owner(s);
2. The party or parties responsible for operation and maintenance, including how future property owners shall be notified of the presence of the stormwater management system and the requirement for operation and maintenance;
3. The routine and non-routine maintenance tasks to be undertaken after construction is complete and a schedule for implementing those tasks;
4. A plan that is drawn to scale and shows the location of all stormwater BMPs in each treatment train along with the discharge point;
5. A description and delineation of public safety features; and
6. An estimated operations and maintenance budget.

SECTION 2 Long-Term Pollution Prevention Plan

The Responsible Party shall implement the following good housekeeping procedures at the project site to reduce the possibility of accidental releases and to reduce safety hazards.

Storage of Hazardous Materials

To prevent leaks and spills, keep hazardous materials and waste products under cover or inside. Use drip pans or spill containment systems to prevent chemicals from entering the drainage system. Inspect storage areas for materials and waste products at least once per year to determine amount and type of the material on site, and if the material requires disposal.

Securely store liquid petroleum products and other liquid chemicals in federally- and state-approved containers. Restrict access to maintenance personnel and administrators.

Storage of Waste Products

Collect and store all waste materials in securely lidded dumpster(s) or other secure containers as applicable to the material. Keep dumpster lids closed and the areas around them clean. Do not fill the dumpsters with liquid waste or hose them out. Sweep areas around the dumpster regularly and put the debris in the garbage, instead of sweeping or hosing it into the parking lot. Legally dispose of collected waste on a regular basis.

Segregate liquid wastes from solid waste and recycle through hazardous waste disposal companies, whenever possible. Contact a hazardous waste hauler for proper disposal to a hazardous waste collection center.

Spill Prevention and Response

Implement spill response procedures for releases of significant materials such as fuels, oils, or chemical materials onto the ground or other area that could reasonably be expected to discharge to surface or groundwater.

1. For minor spills, keep fifty (50) gallon spill control kits and Speedy Dry at all shop and work areas.
2. Immediately contact applicable Federal, State, and local agencies for reportable quantities as required by law.
3. Immediately perform applicable containment and cleanup procedures following a spill release.
4. Promptly remove and dispose of all material collected during the response in accordance with Federal, State, and local requirements. A licensed emergency response contractor may be required to assist in cleanup of releases depending on the amount of the release, and the ability of the Contractor to perform the required response.
5. Reportable quantities of chemicals, fuels, or oils are established under the Clean Water Act and enforced through MassDEP.

Minimize Soil Erosion

Soil erosion facilitates mechanical transport of nutrients, pathogens, and organic matter to surface water bodies. Repair all areas where erosion is occurring throughout the project site. Stabilize bare soil with riprap, seed, mulch, or vegetation.

Management of Deicing Chemicals and Snow

The qualified contractor selected for snow plowing and deicing shall be made fully aware of the requirements of this section.



During typical snow plowing operations, snow shall be pushed to the designated snow removal areas. Snow shall not be stockpiled in wetland resource areas or the 100-foot Buffer Zone or catch basins. In severe conditions where snow cannot be stockpiled on site, the snow shall be removed from the site and properly disposed of in accordance with DEP Guideline BRP601-01.

Use of sand is permitted only for impervious roadways and parking areas.

Before winter begins, the property owner and the contractor shall review snow plowing, deicing, and stockpiling procedures. Areas designated for stockpiling should be cleaned of any debris. Street and parking lot sweeping should be followed in accordance with the Operation and Maintenance Plan.

Coordination with other Permits and Requirements

Certain conditions of other approvals affecting the long-term management of the property shall be considered part of this Long-Term Pollution Prevention Plan. The Owner shall become familiar with those documents and comply with the guidelines set forth in those documents.

SECTION 3 Stormwater Management System Operation and Maintenance Plan

Introduction

This Operation and Maintenance Plan (O&M Plan) for P&G Andover Manufacturing Center Enhancement Project is required under Standard 9 of the 2008 MassDEP Stormwater Handbook to provide best management practices for implementing maintenance activities for the stormwater management system in a manner that minimizes impacts to wetland resource areas.

The Owner shall implement this O&M Plan and proactively conduct operations at the site in an environmentally responsible manner. Compliance with this O&M Plan does not in any way dismiss the Owner from compliance with other applicable Federal, State or local laws.

Routine maintenance during construction and post-development phases of the project, as defined in the Operation and Maintenance Plan, shall be permitted without amendment to the Order of Conditions. A continuing condition in the Certificate of Compliance shall ensure that maintenance can be performed without triggering further filings under the Wetlands Protection Act.

All stormwater best management practices (BMPs) shall be operated and maintained in accordance with the design plans and the Operation and Maintenance Plan approved by the issuing authority. The Owner shall:

1. Maintain an operation and maintenance log for the last three years, including inspections, repairs, replacement, and disposal (for disposal the log shall indicate the type of material and the disposal location). This is a rolling log in which the responsible party records all operation and maintenance activities for the past three years.
2. Make this log available to MassDEP and the Conservation Commission upon request; and
3. Allow members and agents of the MassDEP and the Conservation Commission to enter and inspect the premises to evaluate and ensure that the Owner complies with the Operation and Maintenance requirements for each BMP.

Stormwater Operation and Maintenance Requirements

Inspect and maintain the stormwater management system as directed below. Refer to the design drawings for the location of each component of the system. Repairs to any component of the system shall be made as soon as possible to prevent any potential pollutants (including silt) from entering the resource areas.

Deep Sump and Hooded Catch Basins

Inspect or clean catch basins four times per year and at the end of foliage and snow-removal seasons. Other inspection and maintenance requirements include:

1. Remove organic material, sediment and hydrocarbons four times per year or whenever the depth of deposits is greater than or equal to one half the depth from the bottom of the invert of the lowest pipe in the basin.
2. Always clean out catch basins after street sweeping. If any evidence of hydrocarbons is found during inspection, immediately remove the material using absorbent pads or other suitable measures and dispose of legally. Remove other accumulated debris as necessary.
3. If handling runoff from land uses with higher potential pollutant loads or discharging runoff near or to a critical area, more frequent cleaning may be necessary.
4. Transport and disposal of accumulated sediment off-site shall be in accordance with applicable local, state and federal guidelines and regulations.



Area Drains

Inspect area drains at least once per month and remove debris from the grate. Clean out accumulated sediments at least once per year and more frequently as necessary.

Water Quality Units (Proprietary Separators)

Maintain water quality units according to the recommendations set forth by the manufacturer. General inspection and maintenance procedures for proprietary devices are provided below:

1. Inspect units following completion of construction, prior to being put into service.
2. Inspect units at least twice per year following installation and no less than once per year thereafter.
3. Inspect units immediately after any oil, fuel or chemical spill.
4. All inspections shall include checking the oil level and sediment depth in the unit. Removal of sediments/oils shall occur per manufacturer recommendations.
5. A licensed waste management company shall remove captured petroleum waste products from any oil, chemical or fuel spills and dispose.
6. OSHA confined space entry protocols shall be followed if entry into the unit is required.

Subsurface Detention/Infiltration Structures

1. Inspect subsurface detention/infiltration structures twice per year. Inspect the inlets and observation ports to determine if there is accumulated sediment within the system. Remove all debris and accumulated sediment that may clog the system.

Rain Guardian Inlets

Maintain Rain Guardian units with the recommendations set forth by the manufacturer. General Inspection and maintenance procedures for the proprietary devices are provided below:

1. Inspect the units following completion of construction, prior to being put into service.
2. Inspect the units at least twice per year following installation and no less than once per year thereafter.
3. Inspect units immediately after any oil, fuel or chemical spill.
4. All inspections shall include checking the oil level and sediment depth in the unit. Removal of sediments/oils shall occur per manufacturer recommendations.
5. A licensed waste management company shall remove captured petroleum waste products from any oil, chemical or fuel spills and dispose.
6. OSHA confined space entry protocols shall be followed if entry into the unit is required.

Repair of the Stormwater Management System

The stormwater management system shall be maintained. The repair of any component of the system shall be made as soon as possible to prevent any potential pollutants including silt from entering the resource areas or the existing closed drainage system.



Estimated Operations and Maintenance Budget

An Operations and Maintenance Budget was prepared in compliance with the MassDEP Stormwater Standards.

Table 2. Operations and Maintenance Budget

BMP Type	# of BMPs	Annual O & M Cost (per BMP)	Total Cost
Catch Basin	31	\$240-\$480	\$7,440-\$14,880
Subsurface Infiltration System	4	\$200-\$400	\$800-\$1,600
Water Quality Units	19	\$120-\$360	\$2,280-\$6,840
Total:			\$10,520-\$23,320

Reporting

The Owner shall maintain a record of drainage system inspections and maintenance (per this Plan) and submit a yearly report to the Andover Conservation Commission.

STORMWATER MANAGEMENT SYSTEM INSPECTION FORM

P&G Andover Manufacturing Center Enhancement Project Inspected by: _____ Andover, MA Date: _____		
Component	Status/Inspection	Action Taken
Deep Sump Catch Basins, Area Drains and Drain Manholes		
CB 131		
CB 120		
CB 119		
CB 101		
CB 100		
CB 102		
CB 103		
CB 104		



CB 105		
CB 107		
CB 108		
EX CB 1		
EX CB 2		
CB 128		
CB 129		
CB 130		
CB 126 Silt Prison		
CB 121 Silt Prison		



CB 134 Silt Prison		
CB 123 Silt Prison		
CB 124 Silt Prison		
CB 122 Silt Prison		
CB 133 Silt Prison		
CB 132 Silt Prison		
CB 111		
CB 112		
CB 110		
CB 109		

DMH 257		
DMH 249		
DMH 258		
DMH 202		
DMH 205		
DMH 206		
DMH 207		
DMH 217		
DMH 200		
DMH 229		



DMH 235		
DMH 260		
DMH 201		
DMH 251		
DMH 252		
DMH 253		
DMH 240		
DMH 228		
DMH 256		
DMH 239		



DMH 242		
DMH 241		
DMH 247		
DMH 248		
DMH 216		
DMH 230		
DMH 251		
AD 253		
WQS 245		
WQS 233		



WQS 244		
WQS 204		
WQS 246		
WQS 205		
WQS 203		
WQS 206		
WQS 208		
WQS 207		
WQS 212		
WQS 209		

Subsurface System #1		
Subsurface System #2		
Subsurface System #3		
Subsurface System #4		
Outlet Control Structures		
Flared End Section #1		
Existing Flared End Section 48" Pipe		
Rain Guardian #1		
Rain Guardian #2		
Rain Guardian #3		



Rain Guardian #4		
General site conditions – evidence of erosion, etc.		

SUBMIT COPIES OF STORMWATER MANAGEMENT SYSTEM INSPECTION FORM TO THE ANDOVER CONSERVATION COMMISSION WITH THE YEARLY REPORT.



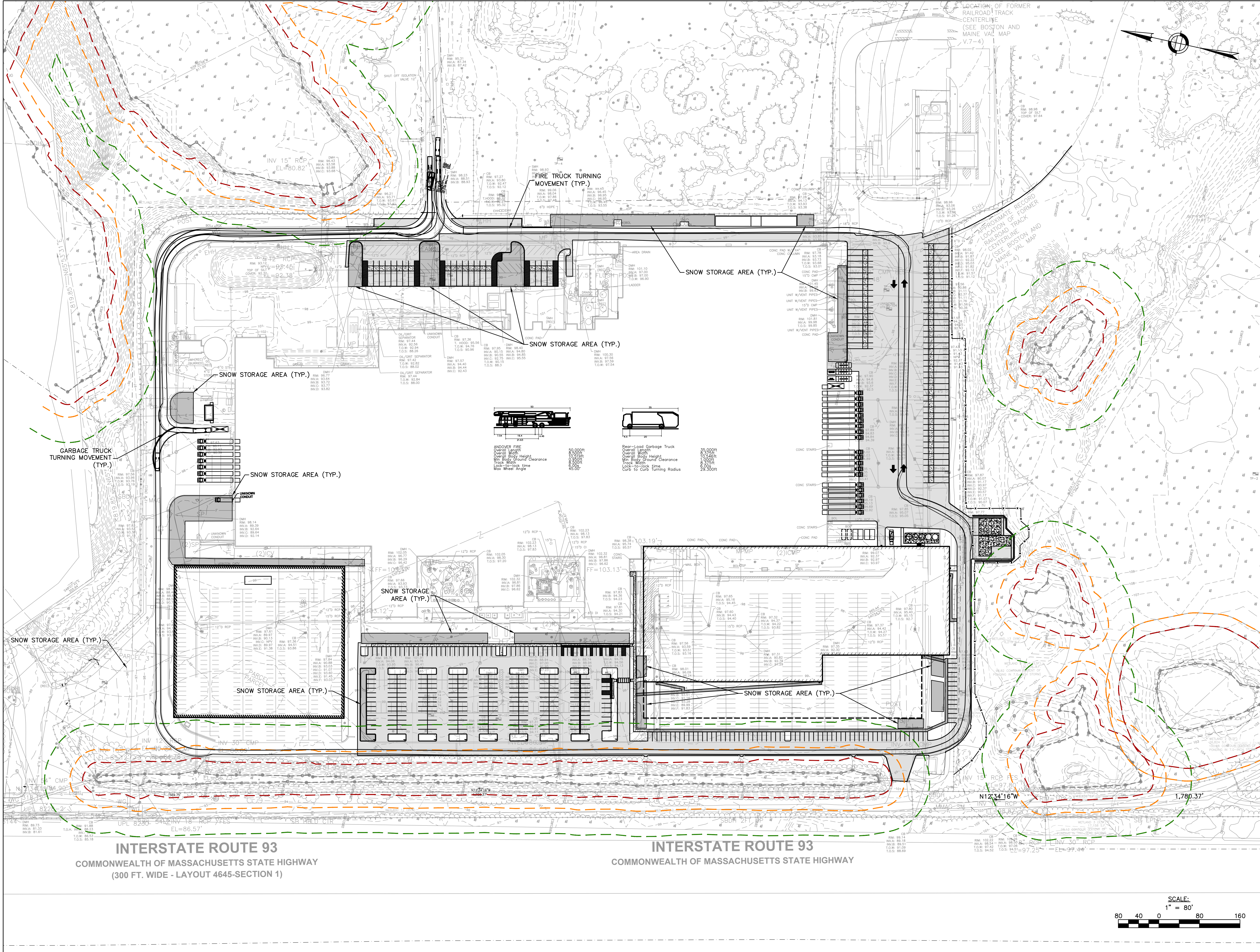

Project:
**P&G ANDOVER
 MANUFACTURING
 CENTER
 ENHANCEMENT
 PROJECT**
 30 BURTT ROAD
 ANDOVER, MA 01810

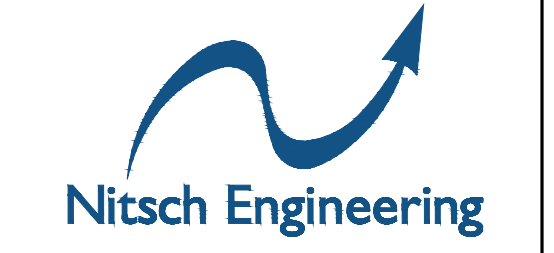

PERMITTING SET
 NOT FOR
 CONSTRUCTION

16 APRIL 2024

Key Plan:

Stamp:

No.	Date	Revision
13	07/12/2024	BULLETIN 13
14	07/30/2024	RESPONSE TO PEER REVIEW COMMENTS
15	08/27/2024	RESPONSE TO PEER REVIEW COMMENTS

Job No.: 15363
 Drawn By: BJB/OFY/LMC
 Checked By: DLC
 Date: 04/16/2024
 Scale: AS NOTED

Drawing Title:
**SNOW STORAGE AND
 FIRETRUCK TURNING
 PLAN**

Drawing No.:
C-003

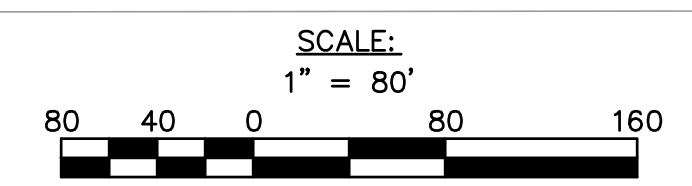

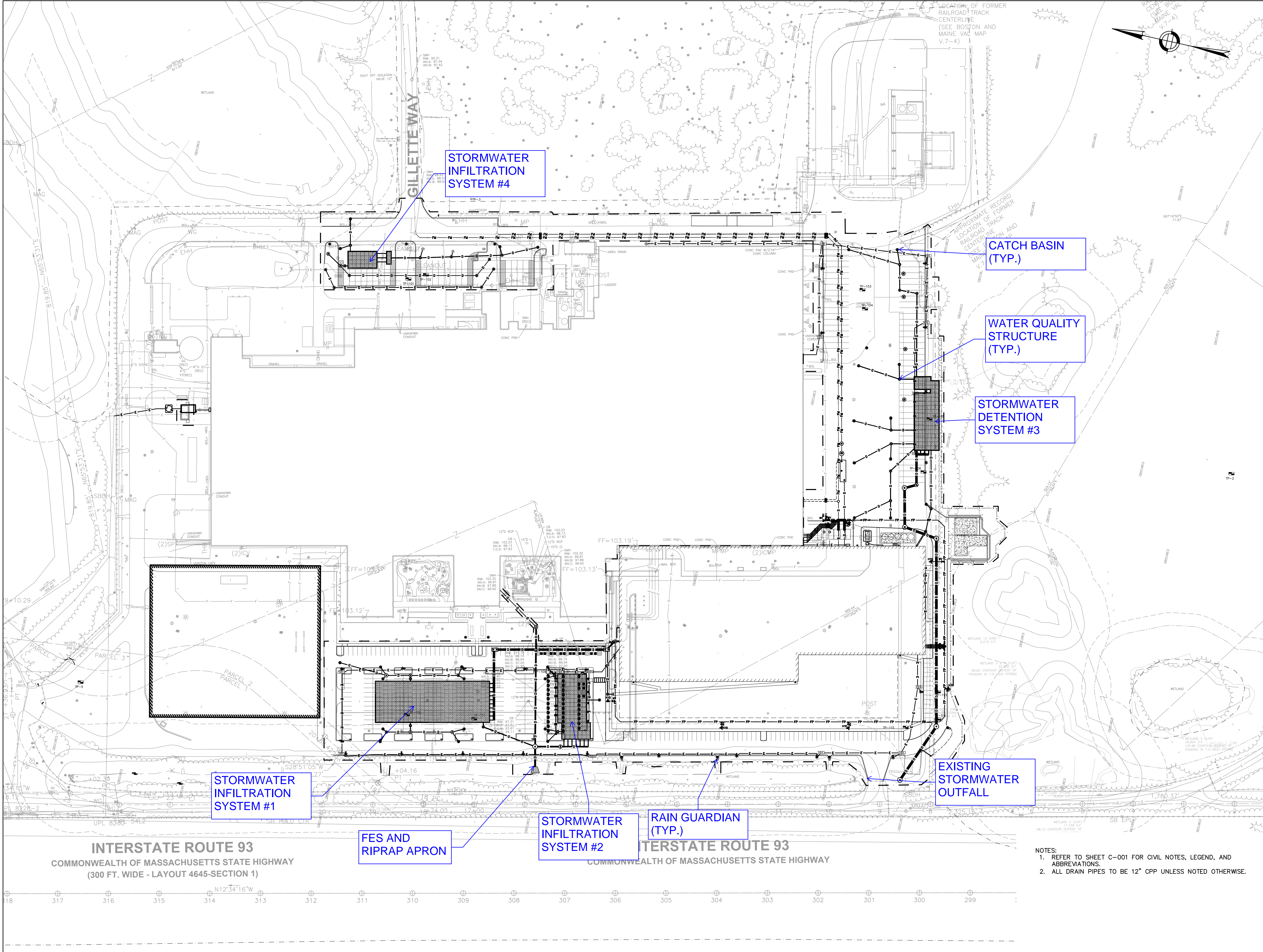

Project:
**P&G ANDOVER
 MANUFACTURING
 CENTER
 ENHANCEMENT
 PROJECT**
 30 BURTT ROAD
 ANDOVER, MA 01810

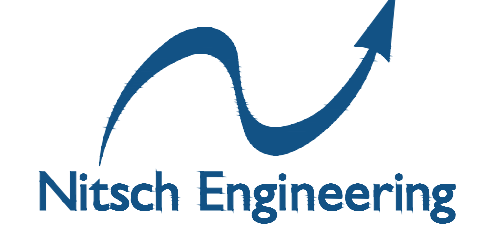

PERMITTING SET
 NOT FOR
 CONSTRUCTION

16 APRIL 2024

Key Plan:

Stamp:

No.	Date	Revision
13	07/12/2024	BULLETIN 13
14	07/30/2024	RESPONSE TO PEER REVIEW COMMENTS
15	08/27/2024	RESPONSE TO PEER REVIEW COMMENTS

Job No.:	15363
Drawn By:	BJB/OFY/LMC
Checked By:	DLC
Date:	04/16/2024
Scale:	AS NOTED

Drawing Title:
**SITE UTILITY
 PLAN**

Drawing No.:

NOTES:
 1. REFER TO SHEET C-001 FOR CIVIL NOTES, LEGEND, AND ABBREVIATIONS.
 2. ALL DRAIN PIPES TO BE 12" CPP UNLESS NOTED OTHERWISE.



PRETREATMENT FOR BIORETENTION

Rain Gardens • Swales • Filtration Basins • Infiltration Basins



TURRET



FOXHOLE



BUNKER

Maintenance Guide

Rain Guardian pretreatment chambers simplify bioretention maintenance by collecting sand, leaves, grass clippings, and other debris in an easy to clean, confined location. Regularly maintaining the Rain Guardian sustains its functionality by maximizing storage and filtration capacities. Maintenance frequency is variable and depends on many factors such as rainfall frequency, drainage area size and land use type, and season of the year. The general cleaning process is similar for all Rain Guardian models (i.e. Bunker, Foxhole, and Turret).

Following rain events, inspect the pretreatment chamber for debris on the top grate, within the chamber, and on the vertical, drop-in filter wall. The maintenance steps described below should be completed if areas of the top grate are clogged, the chamber is >75% full, or the vertical filter wall is clogged. Maintenance should be completed when stormwater has completely drained from the bioretention practice. The filter wall allows the chamber to dry between rain events, which further simplifies maintenance by ensuring removed debris is largely dry. Ensure all debris collected during cleaning of the chamber is completely removed from the site and properly disposed of according to local environmental rules. Once cleaning is complete, reinstall the filter wall with filter fabric facing the inside of the chamber and replace the top grate. For the Foxhole, reinstall the top lid, including optional lid anchor screws if equipped.



Clear Debris from Top Grate

- Foxhole only—remove top lid, including optional lid anchor screws if equipped
- Leaf litter and garbage commonly accumulate on the top grate
- Simply remove and dispose of debris by hand or with a shovel prior to removing top grate



Remove Debris from Inside Chamber

- Remove top grate and place on paved inlet to avoid damage to nearby plants
- Remove and dispose of accumulated debris within chamber using a shovel



Clean Filter Wall

- Remove drop-in filter by lifting vertically
- Clean filter wall with a stiff bristled broom or rinse clean with pressurized water

Stormceptor[®] STC
Operation and Maintenance Guide

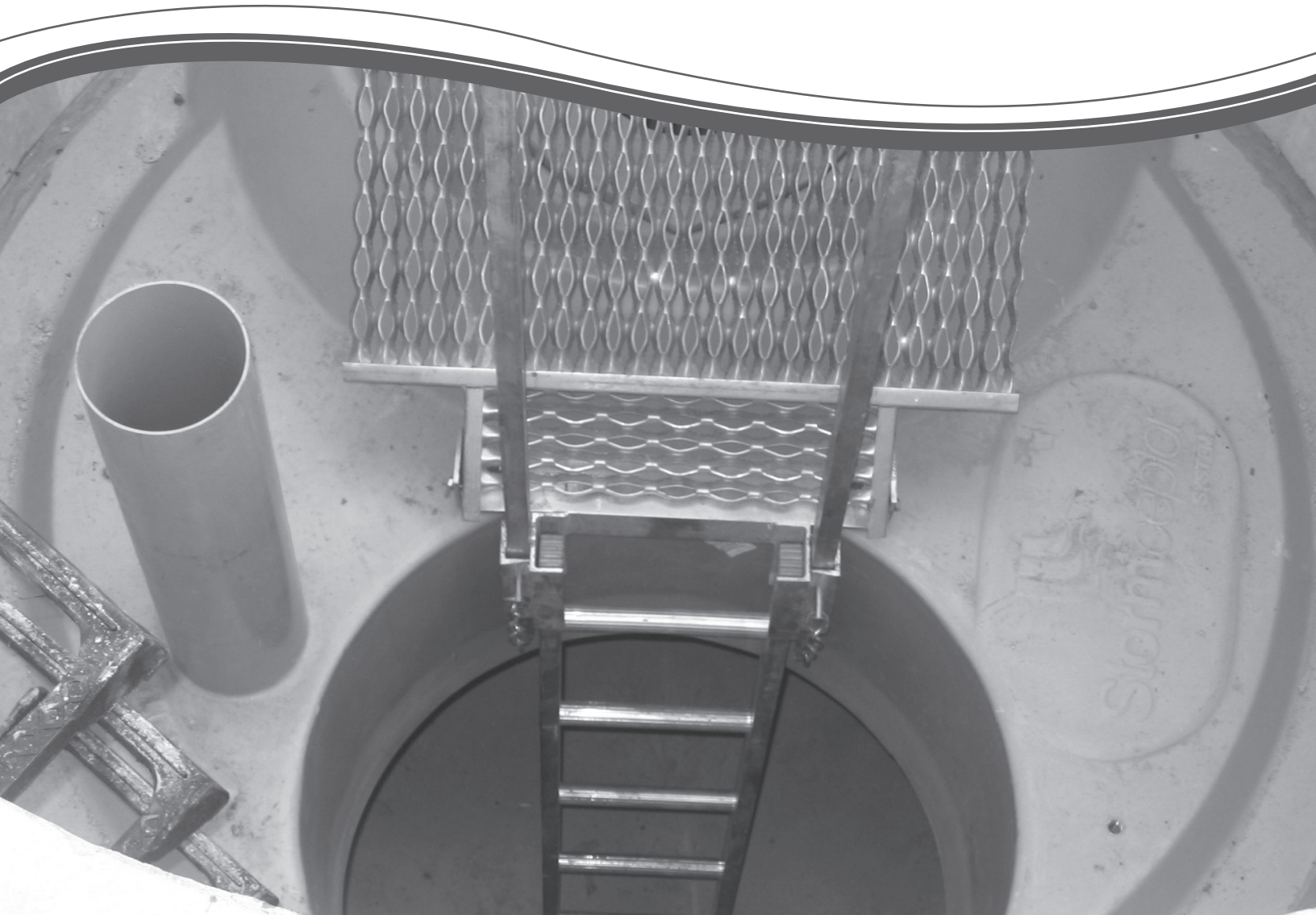

Stormceptor Design Notes

- Only the STC 450i is adaptable to function with a catch basin inlet and/or inline pipes.
- Only the Stormceptor models STC 450i to STC 7200 may accommodate multiple inlet pipes.

Inlet and outlet invert elevation differences are as follows:

Inlet and Outlet Pipe Invert Elevations Differences			
Inlet Pipe Configuration	STC 450i	STC 900 to STC 7200	STC 11000 to STC 16000
Single inlet pipe	3 in. (75 mm)	1 in. (25 mm)	3 in. (75 mm)
Multiple inlet pipes	3 in. (75 mm)	3 in. (75 mm)	Only one inlet pipe.

Maximum inlet and outlet pipe diameters:

Inlet/Outlet Configuration	Inlet Unit STC 450i	In-Line Unit STC 900 to STC 7200	Series* STC 11000 to STC 16000
Straight Through	24 inch (600 mm)	42 inch (1050 mm)	60 inch (1500 mm)
Bend (90 degrees)	18 inch (450 mm)	33 inch (825 mm)	33 inch (825 mm)

- The inlet and in-line Stormceptor units can accommodate turns to a maximum of 90 degrees.
- Minimum distance from top of grade to crown is 2 feet (0.6 m)
- Submerged conditions. A unit is submerged when the standing water elevation at the proposed location of the Stormceptor unit is greater than the outlet invert elevation during zero flow conditions. In these cases, please contact your local Stormceptor representative and provide the following information:
 - Top of grade elevation
 - Stormceptor inlet and outlet pipe diameters and invert elevations
 - Standing water elevation
 - Stormceptor head loss, $K = 1.3$ (for submerged condition, $K = 4$)



OPERATION AND MAINTENANCE GUIDE

Table of Content

1. About Stormceptor	4
2. Stormceptor Design Overview	4
3. Key Operation Features	6
4. Stormceptor Product Line.....	7
5. Sizing the Stormceptor System.....	10
6. Spill Controls.....	12
7. Stormceptor Options.....	14
8. Comparing Technologies	17
9. Testing.....	18
10. Installation	18
11. Stormceptor Construction Sequence.....	18
12. Maintenance	19

1. About Stormceptor

The Stormceptor® STC (Standard Treatment Cell) was developed by Imbrium™ Systems to address the growing need to remove and isolate pollution from the storm drain system before it enters the environment. The Stormceptor STC targets hydrocarbons and total suspended solids (TSS) in stormwater runoff. It improves water quality by removing contaminants through the gravitational settling of fine sediments and floatation of hydrocarbons while preventing the re-suspension or scour of previously captured pollutants.

The development of the Stormceptor STC revolutionized stormwater treatment, and created an entirely new category of environmental technology. Protecting thousands of waterways around the world, the Stormceptor System has set the standard for effective stormwater treatment.

1.1. Patent Information

The Stormceptor technology is protected by the following patents:

- Australia Patent No. 693,164 • 693,164 • 707,133 • 729,096 • 779401
- Austrian Patent No. 289647
- Canadian Patent No 2,009,208 • 2,137,942 • 2,175,277 • 2,180,305 • 2,180,383 • 2,206,338 • 2,327,768 (Pending)
- China Patent No 1168439
- Denmark DK 711879
- German DE 69534021
- Indonesian Patent No 16688
- Japan Patent No 9-11476 (Pending)
- Korea 10-2000-0026101 (Pending)
- Malaysia Patent No PI9701737 (Pending)
- New Zealand Patent No 314646
- United States Patent No 4,985,148 • 5,498,331 • 5,725,760 • 5,753,115 • 5,849,181 • 6,068,765 • 6,371,690
- Stormceptor OSR Patent Pending • Stormceptor LCS Patent Pending

2. Stormceptor Design Overview

2.1. Design Philosophy

The patented Stormceptor System has been designed to focus on the environmental objective of providing long-term pollution control. The unique and innovative Stormceptor design allows for continuous positive treatment of runoff during all rainfall events, while ensuring that all captured pollutants are retained within the system, even during intense storm events.

An integral part of the Stormceptor design is PCSWMM for Stormceptor - sizing software developed in conjunction with Computational Hydraulics Inc. (CHI) and internationally acclaimed expert, Dr. Bill James. Using local historical rainfall data and continuous simulation modeling, this software allows a Stormceptor unit to be designed for each individual site and the corresponding water quality objectives.

By using PCSWMM for Stormceptor, the Stormceptor System can be designed to remove a wide range of particles (typically from 20 to 2,000 microns), and can also be customized to remove a specific particle size distribution (PSD). The specified PSD should accurately reflect what is in the stormwater runoff to ensure the device is achieving the desired water quality objective. Since stormwater runoff contains small particles (less than 75 microns), it is important to design a treatment system to remove smaller particles in addition to coarse particles.

2.2. Benefits

The Stormceptor System removes free oil and suspended solids from stormwater, preventing spills and non-point source pollution from entering downstream lakes and rivers. The key benefits, capabilities and applications of the Stormceptor System are as follows:

- Provides continuous positive treatment during all rainfall events
- Can be designed to remove over 80% of the annual sediment load
- Removes a wide range of particles
- Can be designed to remove a specific particle size distribution (PSD)
- Captures free oil from stormwater
- Prevents scouring or re-suspension of trapped pollutants
- Pre-treatment to reduce maintenance costs for downstream treatment measures (ponds, swales, detention basins, filters)
- Groundwater recharge protection
- Spills capture and mitigation
- Simple to design and specify
- Designed to your local watershed conditions
- Small footprint to allow for easy retrofit installations
- Easy to maintain (vacuum truck)
- Multiple inlets can connect to a single unit
- Suitable as a bend structure
- Pre-engineered for traffic loading (minimum AASHTO HS-20)
- Minimal elevation drop between inlet and outlet pipes
- Small head loss
- Additional protection provided by an 18" (457 mm) fiberglass skirt below the top of the insert, for the containment of hydrocarbons in the event of a spill.

2.3. Environmental Benefit

Freshwater resources are vital to the health and welfare of their surrounding communities. There is increasing public awareness, government regulations and corporate commitment to reducing the pollution entering our waterways. A major source of this pollution originates from stormwater runoff from urban areas. Rainfall runoff carries oils, sediment and other contaminants from roads and parking lots discharging directly into our streams, lakes and coastal waterways.

The Stormceptor System is designed to isolate contaminants from getting into the natural environment. The Stormceptor technology provides protection for the environment from spills that occur at service stations and vehicle accident sites, while also removing contaminated sediment in runoff that washes from roads and parking lots.

3. Key Operation Features

3.1. Scour Prevention

A key feature of the Stormceptor System is its patented scour prevention technology. This innovation ensures pollutants are captured and retained during all rainfall events, even extreme storms. The Stormceptor System provides continuous positive treatment for all rainfall events, including intense storms. Stormceptor slows incoming runoff, controlling and reducing velocities in the lower chamber to create a non-turbulent environment that promotes free oils and floatable debris to rise and sediment to settle.

The patented scour prevention technology, the fiberglass insert, regulates flows into the lower chamber through a combination of a weir and orifice while diverting high energy flows away through the upper chamber to prevent scouring. Laboratory testing demonstrated no scouring when tested up to 125% of the unit's operating rate, with the unit loaded to 100% sediment capacity (NJDEP, 2005). Second, the depth of the lower chamber ensures the sediment storage zone is adequately separated from the path of flow in the lower chamber to prevent scouring.

3.2. Operational Hydraulic Loading Rate

Designers and regulators need to evaluate the treatment capacity and performance of manufactured stormwater treatment systems. A commonly used parameter is the "operational hydraulic loading rate" which originated as a design methodology for wastewater treatment devices.

Operational hydraulic loading rate may be calculated by dividing the flow rate into a device by its settling area. This represents the critical settling velocity that is the prime determinant to quantify the influent particle size and density captured by the device. PCSWMM for Stormceptor uses a similar parameter that is calculated by dividing the hydraulic detention time in the device by the fall distance of the sediment.

$$v_{sc} = \frac{H}{\theta_H} = \frac{Q}{A_s}$$

Where:

v_{sc} = critical settling velocity, ft/s (m/s)

H = tank depth, ft (m)

θ_H = hydraulic detention time, ft/s (m/s)

Q = volumetric flow rate, ft³/s (m³/s)

A_s = surface area, ft² (m²)

(Tchobanoglous, G. and Schroeder, E.D. 1987. Water Quality. Addison Wesley.)

Unlike designing typical wastewater devices, stormwater systems are designed for highly variable flow rates including intense peak flows. PCSWMM for Stormceptor incorporates all of the flows into its calculations, ensuring that the operational hydraulic loading rate is considered not only for one flow rate, but for all flows including extreme events.

3.3. Double Wall Containment

The Stormceptor System was conceived as a pollution identifier to assist with identifying illicit discharges. The fiberglass insert has a continuous skirt that lines the concrete barrel wall for a depth of 18 inches (457 mm) that provides double wall containment for hydrocarbons storage. This protective barrier ensures that toxic floatables do not migrate through the concrete wall into the surrounding soils.

4. Stormceptor Product Line

4.1. Stormceptor Models

A summary of Stormceptor models and capacities are listed in Table 1.

Table 1. Stormceptor Models

Stormceptor Model	Total Storage Volume U.S. Gal (L)	Hydrocarbon Storage Capacity U.S. Gal (L)	Maximum Sediment Capacity ft ³ (L)
STC 450i	470 (1,780)	86 (330)	46 (1,302)
STC 900	952 (3,600)	251 (950)	89 (2,520)
STC 1200	1,234 (4,670)	251 (950)	127 (3,596)
STC 1800	1,833 (6,940)	251 (950)	207 (5,861)
STC 2400	2,462 (9,320)	840 (3,180)	205 (5,805)
STC 3600	3,715 (1,406)	840 (3,180)	373 (10,562)
STC 4800	5,059 (1,950)	909 (3,440)	543 (15,376)
STC 6000	6,136 (23,230)	909 (3,440)	687 (19,453)
STC 7200	7,420 (28,090)	1,059 (4,010)	839 (23,757)
STC 11000	11,194 (42,370)	2,797 (10, 590)	1,086 (30,752)
STC 13000	13,348 (50,530)	2,797 (10, 590)	1,374 (38,907)
STC 16000	15,918 (60,260)	3,055 (11, 560)	1,677 (47,487)

NOTE: Storage volumes may vary slightly from region to region. For detailed information, contact your local Stormceptor representative.

4.2. Inline Stormceptor

The Inline Stormceptor, Figure 1, is the standard design for most stormwater treatment applications. The patented Stormceptor design allows the Inline unit to maintain continuous positive treatment of total suspended solids (TSS) year-round, regardless of flow rate. The Inline Stormceptor is composed of a precast concrete tank with a fiberglass insert situated at the invert of the storm sewer pipe, creating an upper chamber above the insert and a lower chamber below the insert.

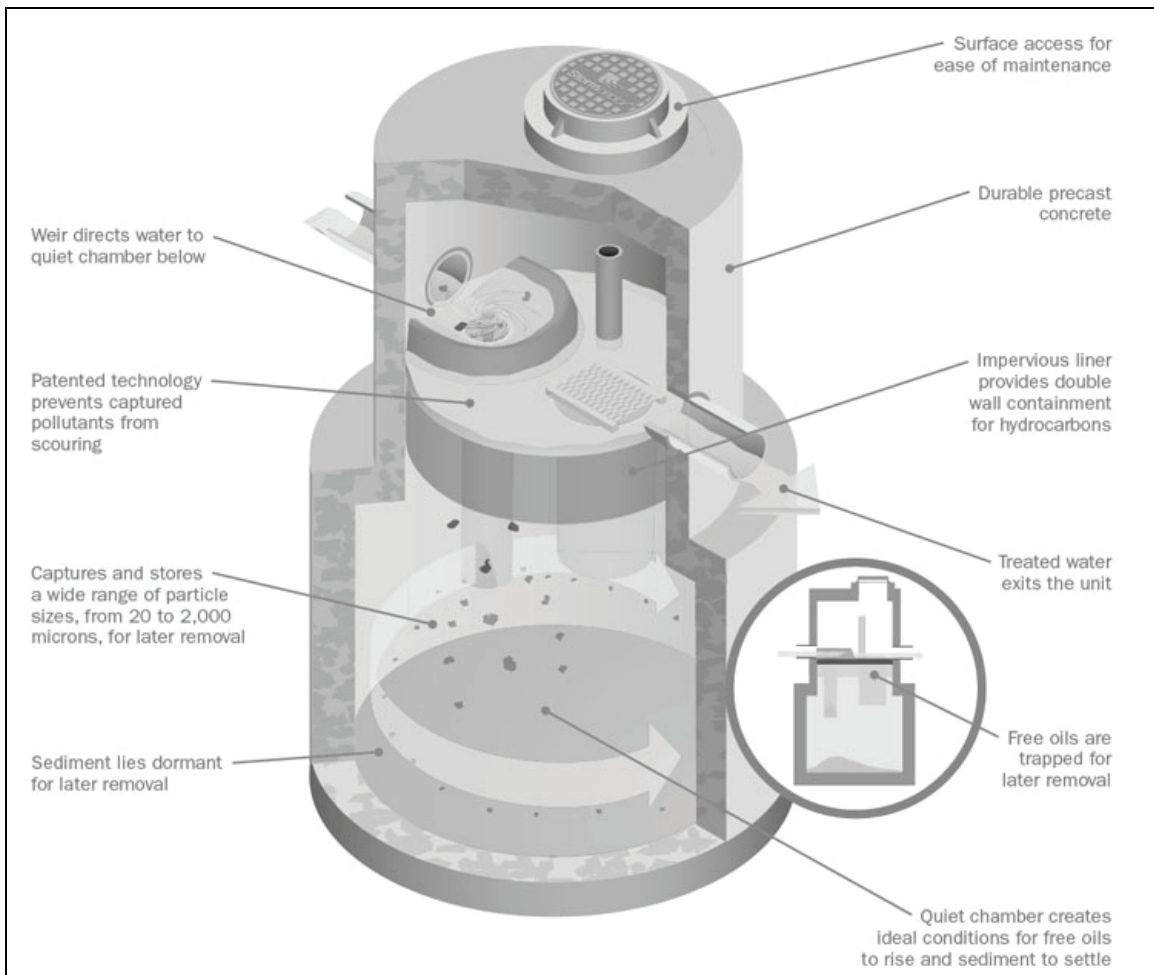

Figure 1. Inline Stormceptor

Operation

As water flows into the Stormceptor unit, it is slowed and directed to the lower chamber by a weir and drop tee. The stormwater enters the lower chamber, a non-turbulent environment, allowing free oils to rise and sediment to settle. The oil is captured underneath the fiberglass insert and shielded from exposure to the concrete walls by a fiberglass skirt. After the pollutants separate, treated water continues up a riser pipe, and exits the lower chamber on the downstream side of the weir before leaving the unit. During high flow events, the Stormceptor System's patented scour prevention technology ensures continuous pollutant removal and prevents re-suspension of previously captured pollutants.

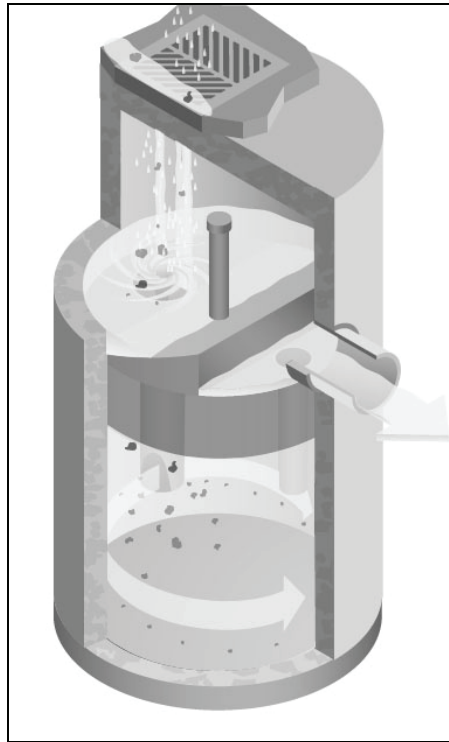

Figure 2. Inlet Stormceptor

4.3. Inlet Stormceptor

The Inlet Stormceptor System, Figure 2, was designed to provide protection for parking lots, loading bays, gas stations and other spill-prone areas. The Inlet Stormceptor is designed to remove sediment from stormwater introduced through a grated inlet, a storm sewer pipe, or both.

The Inlet Stormceptor design operates in the same manner as the Inline unit, providing continuous positive treatment, and ensuring that captured material is not re-suspended.

4.4. Series Stormceptor

Designed to treat larger drainage areas, the Series Stormceptor System, Figure 3, consists of two adjacent Stormceptor models that function in parallel. This design eliminates the need for additional structures and piping to reduce installation costs.

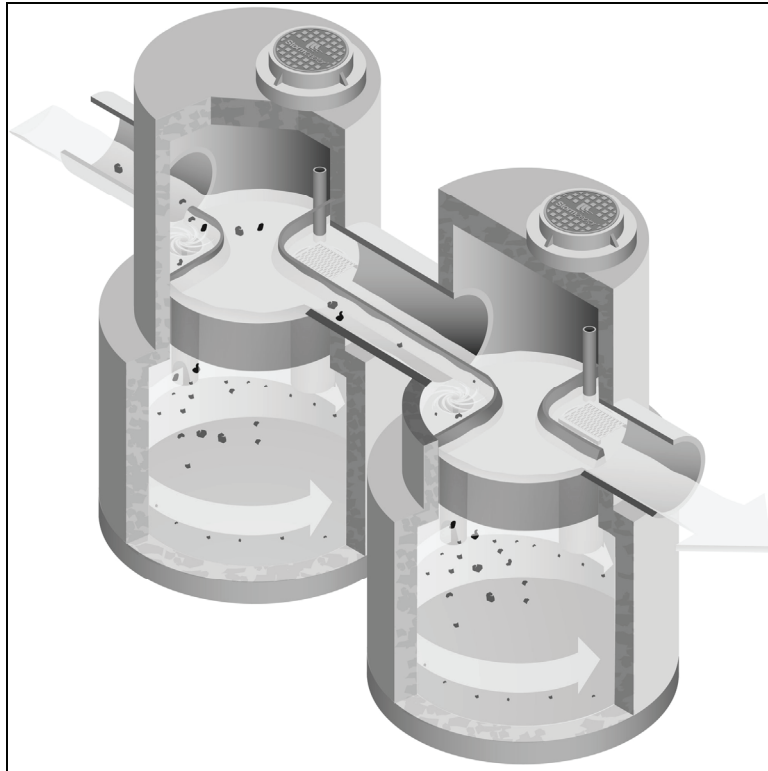

Figure 3. Series System

The Series Stormceptor design operates in the same manner as the Inline unit, providing continuous positive treatment, and ensuring that captured material is not re-suspended.

5. Sizing the Stormceptor System

The Stormceptor System is a versatile product that can be used for many different aspects of water quality improvement. While addressing these needs, there are conditions that the designer needs to be aware of in order to size the Stormceptor model to meet the demands of each individual site in an efficient and cost-effective manner.

PCSWMM for Stormceptor is the support tool used for identifying the appropriate Stormceptor model. In order to size a unit, it is recommended the user follow the seven design steps in the program. The steps are as follows:

STEP 1 – Project Details

The first step prior to sizing the Stormceptor System is to clearly identify the water quality objective for the development. It is recommended that a level of annual sediment (TSS) removal be identified and defined by a particle size distribution.

STEP 2 – Site Details

Identify the site development by the drainage area and the level of imperviousness. It is recommended that imperviousness be calculated based on the actual area of imperviousness based on paved surfaces, sidewalks and rooftops.

STEP 3 – Upstream Attenuation

The Stormceptor System is designed as a water quality device and is sometimes used in conjunction with onsite water quantity control devices such as ponds or underground detention systems. When possible, a greater benefit is typically achieved when installing a Stormceptor unit upstream of a detention facility. By placing the Stormceptor unit upstream of a detention structure, a benefit of less maintenance of the detention facility is realized.

STEP 4 – Particle Size Distribution

It is critical that the PSD be defined as part of the water quality objective. PSD is critical for the design of treatment system for a unit process of gravity settling and governs the size of a treatment system. A range of particle sizes has been provided and it is recommended that clays and silt-sized particles be considered in addition to sand and gravel-sized particles. Options and sample PSDs are provided in PCSWMM for Stormceptor. The default particle size distribution is the Fine Distribution, Table 2, option.

Table 2. Fine Distribution

Particle Size	Distribution	Specific Gravity
20	20%	1.3
60	20%	1.8
150	20%	2.2
400	20%	2.65
2000	20%	2.65

If the objective is the long-term removal of 80% of the total suspended solids on a given site, the PSD should be representative of the expected sediment on the site. For example, a system designed to remove 80% of coarse particles (greater than 75 microns) would provide relatively poor removal efficiency of finer particles that may be naturally prevalent in runoff from the site.

Since the small particle fraction contributes a disproportionately large amount of the total available particle surface area for pollutant adsorption, a system designed primarily for coarse particle capture will compromise water quality objectives.

STEP 5 – Rainfall Records

Local historical rainfall has been acquired from the U.S. National Oceanic and Atmospheric Administration, Environment Canada and regulatory agencies across North America. The rainfall data provided with PCSMM for Stormceptor provides an accurate estimation of small storm hydrology by modeling actual historical storm events including duration, intensities and peaks.

STEP 6 – Summary

At this point, the program may be executed to predict the level of TSS removal from the site. Once the simulation has completed, a table shall be generated identifying the TSS removal of each Stormceptor unit.

STEP 7 – Sizing Summary

Performance estimates of all Stormceptor units for the given site parameters will be displayed in a tabular format. The unit that meets the water quality objective, identified in Step 1, will be highlighted.

5.1. PCSWMM for Stormceptor

The Stormceptor System has been developed in conjunction with PCSWMM for Stormceptor as a technological solution to achieve water quality goals. Together, these two innovations model, simulate, predict and calculate the water quality objectives desired by a design engineer for TSS removal.

PCSWMM for Stormceptor is a proprietary sizing program which uses site specific inputs to a computer model to simulate sediment accumulation, hydrology and long-term total suspended solids removal. The model has been calibrated to field monitoring results from Stormceptor units that have been monitored in North America. The sizing methodology can be described by three processes:

1. Determination of real time hydrology
2. Buildup and wash off of TSS from impervious land areas
3. TSS transport through the Stormceptor (settling and discharge). The use of a calibrated model is the preferred method for sizing stormwater quality structures for the following reasons:
 - » The hydrology of the local area is properly and accurately incorporated in the sizing (distribution of flows, flow rate ranges and peaks, back-to-back storms, inter-event times)
 - » The distribution of TSS with the hydrology is properly and accurately considered in the sizing
 - » Particle size distribution is properly considered in the sizing
 - » The sizing can be optimized for TSS removal
 - » The cost benefit of alternate TSS removal criteria can be easily assessed
 - » The program assesses the performance of all Stormceptor models. Sizing may be selected based on a specific water quality outcome or based on the Maximum Extent Practicable

For more information regarding PCSWMM for Stormceptor, contact your local Stormceptor representative, or visit www.imbriumsystems.com to download a free copy of the program.

5.2. Sediment Loading Characteristics

The way in which sediment is transferred to stormwater can have a considerable effect on which type of system is implemented. On typical impervious surfaces (e.g. parking lots) sediment will build over time and wash off with the next rainfall. When rainfall patterns are examined, a short intense storm will have a higher concentration of sediment than a long slow drizzle. Together with rainfall data representing the site's typical rainfall patterns, sediment loading characteristics play a part in the correct sizing of a stormwater quality device.

Typical Sites

For standard site design of the Stormceptor System, PCSWMM for Stormceptor is utilized to accurately assess the unit's performance. As an integral part of the product's design, the program can be used to meet local requirements for total suspended solid removal. Typical installations of manufactured stormwater treatment devices would occur on areas such as paved parking lots or paved roads. These are considered "stable" surfaces which have non – erodible surfaces.

Unstable Sites

While standard sites consist of stable concrete or asphalt surfaces, sites such as gravel parking lots, or maintenance yards with stockpiles of sediment would be classified as "unstable". These types of sites do not exhibit first flush characteristics, are highly erodible and exhibit atypical sediment loading characteristics and must therefore be sized more carefully. Contact your local Stormceptor representative for assistance in selecting a proper unit sized for such unstable sites.

6. Spill Controls

When considering the removal of total petroleum hydrocarbons (TPH) from a storm sewer system there are two functions of the system: oil removal, and spill capture.

'Oil Removal' describes the capture of the minute volumes of free oil mobilized from impervious surfaces. In this instance relatively low concentrations, volumes and flow rates are considered. While the Stormceptor unit will still provide an appreciable oil removal function during higher flow events and/or with higher TPH concentrations, desired effluent limits may be exceeded under these conditions.

'Spill Capture' describes a manner of TPH removal more appropriate to recovery of a relatively high volume of a single phase deleterious liquid that is introduced to the storm sewer system over a relatively short duration. The two design criteria involved when considering this manner of introduction are overall volume and the specific gravity of the material. A standard Stormceptor unit will be able to capture and retain a maximum spill volume and a minimum specific gravity.

For spill characteristics that fall outside these limits, unit modifications are required. Contact your local Stormceptor Representative for more information.

One of the key features of the Stormceptor technology is its ability to capture and retain spills. While the standard Stormceptor System provides excellent protection for spill control, there are additional options to enhance spill protection if desired.

6.1. Oil Level Alarm

The oil level alarm is an electronic monitoring system designed to trigger a visual and audible alarm when a pre-set level of oil is reached within the lower chamber. As a standard, the oil

level alarm is designed to trigger at approximately 85% of the unit's available depth level for oil capture. The feature acts as a safeguard against spills caused by exceeding the oil storage capacity of the separator and eliminates the need for manual oil level inspection.

The oil level alarm installed on the Stormceptor insert is illustrated in Figure 4.

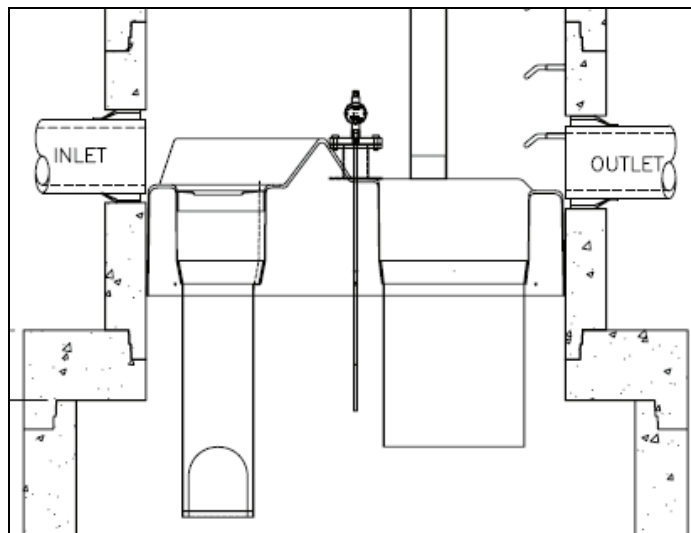

Figure 4. Oil level alarm

6.2. Increased Volume Storage Capacity

The Stormceptor unit may be modified to store a greater spill volume than is typically available. Under such a scenario, instead of installing a larger than required unit, modifications can be made to the recommended Stormceptor model to accommodate larger volumes. Contact your local Stormceptor representative for additional information and assistance for modifications.

7. Stormceptor Options

The Stormceptor System allows flexibility to incorporate to existing and new storm drainage infrastructure. The following section identifies considerations that should be reviewed when installing the system into a drainage network. For conditions that fall outside of the recommendations in this section, please contact your local Stormceptor representative for further guidance.

7.1. Installation Depth Minimum Cover

The minimum distance from the top of grade to the crown of the inlet pipe is 24 inches (600 mm). For situations that have a lower minimum distance, contact your local Stormceptor representative.

7.2. Maximum Inlet and Outlet Pipe Diameters

Maximum inlet and outlet pipe diameters are illustrated in Figure 5. Contact your local Stormceptor representative for larger pipe diameters

Upper Chamber Diameter	Maximum Pipe Diameters for Straight Through and 90° Bends (Based on Concrete Pipe)	
Inlet Stormceptor	24 inch (600 mm)  24 inch (600 mm)	 18 inch (450mm) 18 inch (450mm)
Inline Stormceptor	42 inch (1050 mm)  42 inch (1050 mm)	 33 inch (825 mm) 33 inch (825 mm)
Inline Stormceptor or Series Stormceptor	60 inch (1500 mm)  60 inch (1500 mm)	 42 inch (1050 mm) 42 inch (1050 mm)

Figure 5. Maximum pipe diameters for straight through and bend applications

*The bend should only be incorporated into the second structure (downstream structure) of the Series Stormceptor System

7.3. Bends

The Stormceptor System can be used to change horizontal alignment in the storm drain network up to a maximum of 90 degrees. Figure 6 illustrates the typical bend situations of the Stormceptor System. Bends should only be applied to the second structure (downstream structure) of the Series Stormceptor System.

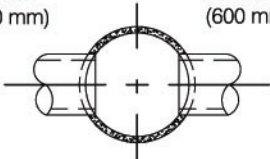
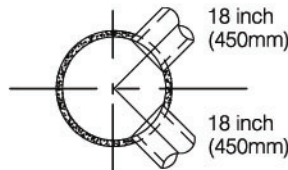
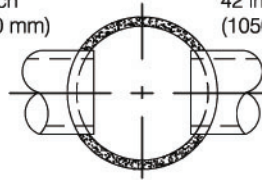
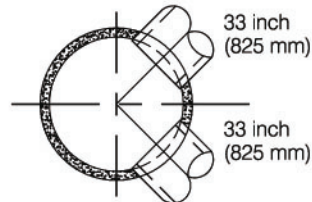
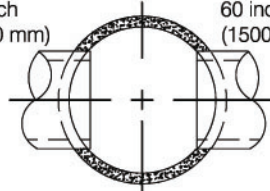
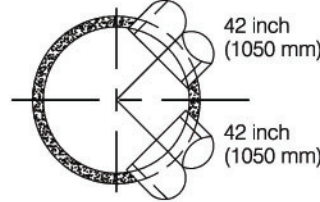
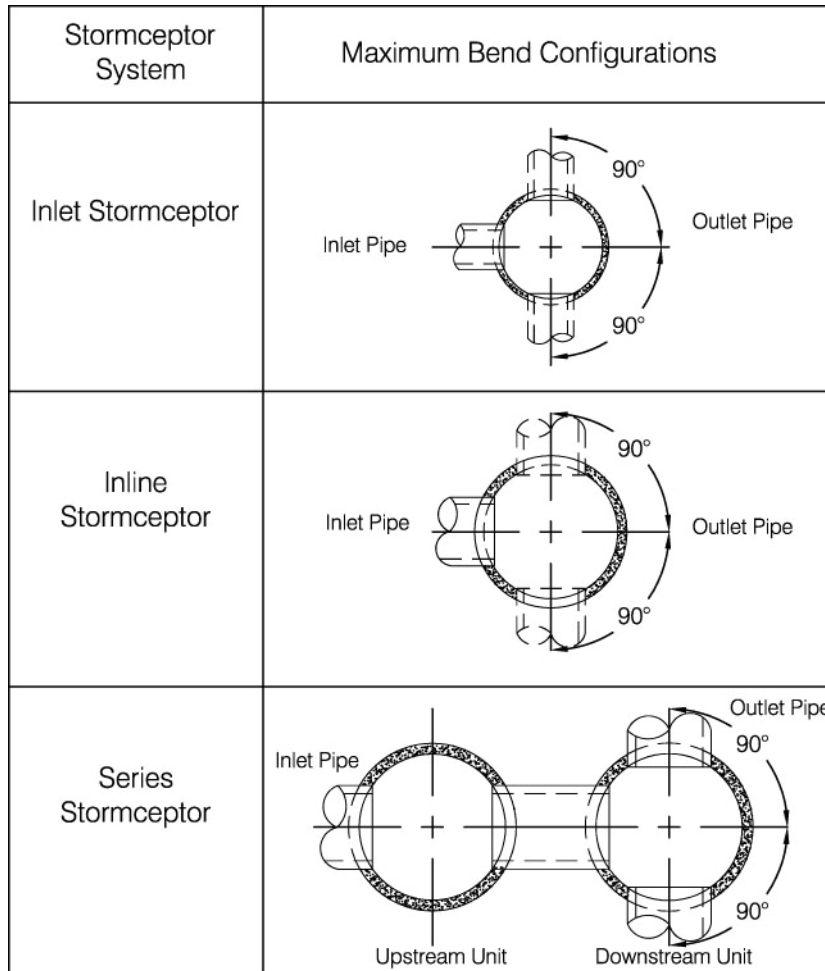

Figure 6. Maximum bend angles

7.4. Multiple Inlet Pipes

The Inlet and Inline Stormceptor System can accommodate two or more inlet pipes. The maximum number of inlet pipes that can be accommodated into a Stormceptor unit is a function of the number, alignment and diameter of the pipes and its effects on the structural integrity of the precast concrete. When multiple inlet pipes are used for new developments, each inlet pipe shall have an invert elevation 3 inches (75 mm) higher than the outlet pipe invert elevation.

7.5. Inlet/Outlet Pipe Invert Elevations

Recommended inlet and outlet pipe invert differences are listed in Table 3.

Table 3. Recommended Drops Between Inlet and Outlet Pipe Inverts

Number of Inlet Pipes	Inlet System	In-Line System	Series System
1	3 inches (75 mm)	1 inch (25 mm)	3 inches (75 mm)
>1	3 inches (75 mm)	3 inches (75 mm)	Not Applicable

7.6. Shallow Stormceptor

In cases where there may be restrictions to the depth of burial of storm sewer systems. In this situation, for selected Stormceptor models, the lower chamber components may be increased in diameter to reduce the overall depth of excavation required.

7.7. Customized Live Load

The Stormceptor system is typically designed for local highway truck loading (AASHTO HS- 20). When the project requires live loads greater than HS-20, the Stormceptor System may be customized structurally for a pre-specified live load. Contact your local Stormceptor representative for customized loading conditions.

7.8. Pre-treatment

The Stormceptor System may be sized to remove sediment and for spills control in conjunction with other stormwater BMPs to meet the water quality objective. For pretreatment applications, the Stormceptor System should be the first unit in a treatment train. The benefits of pre-treatment include the extension of the operational life (extension of maintenance frequency) of large stormwater management facilities, prevention of spills and lower total life-cycle maintenance cost.

7.9. Head loss

The head loss through the Stormceptor System is similar to a 60 degree bend at a manhole. The K value for calculating minor losses is approximately 1.3 (minor loss = $k \cdot 1.3v^2/2g$).

However, when a Submerged modification is applied to a Stormceptor unit, the corresponding K value is 4.

7.10. Submerged

The Submerged modification, Figure 7, allows the Stormceptor System to operate in submerged or partially submerged storm sewers. This configuration can be installed on all models of the Stormceptor System by modifying the fiberglass insert. A customized weir height and a secondary drop tee are added.

Submerged instances are defined as standing water in the storm drain system during zero flow conditions. In these instances, the following information is necessary for the proper design and application of submerged modifications:

- Stormceptor top of grade elevation
- Stormceptor outlet pipe invert elevation
- Standing water elevation

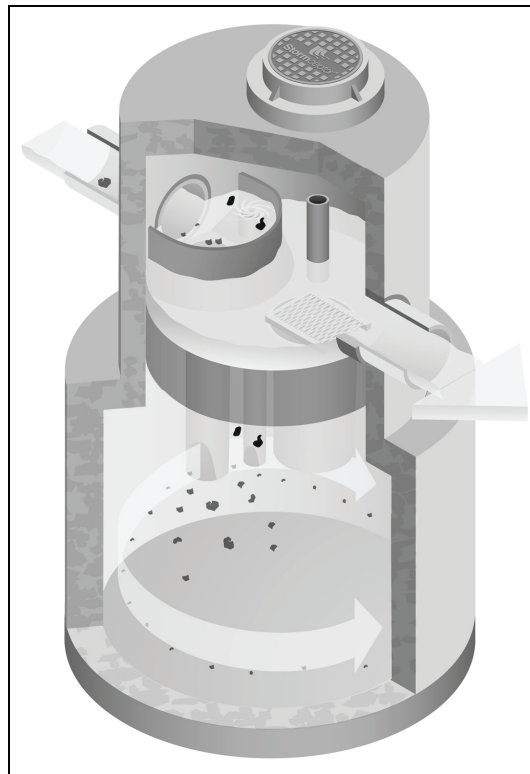

Figure 7. Submerged Stormceptor

8. Comparing Technologies

Designers have many choices available to achieve water quality goals in the treatment of stormwater runoff. Since many alternatives are available for use in stormwater quality treatment it is important to consider how to make an appropriate comparison between “approved alternatives”. The following is a guide to assist with the accurate comparison of differing technologies and performance claims.

8.1. Particle Size Distribution (PSD)

The most sensitive parameter to the design of a stormwater quality device is the selection of the design particle size. While it is recommended that the actual particle size distribution (PSD) for sites be measured prior to sizing, alternative values for particle size should be selected to represent what is likely to occur naturally on the site. A reasonable estimate of a particle size distribution likely to be found on parking lots or other impervious surfaces should consist of a wide range of particles such as 20 microns to 2,000 microns (Ontario MOE, 1994).

There is no absolute right particle size distribution or specific gravity and the user is cautioned to review the site location, characteristics, material handling practices and regulatory requirements when selecting a particle size distribution. When comparing technologies, designs using different PSDs will result in incomparable TSS removal efficiencies. The PSD of the TSS removed needs to be standard between two products to allow for an accurate comparison.

8.2. Scour Prevention

In order to accurately predict the performance of a manufactured treatment device, there must be confidence that it will perform under all conditions. Since rainfall patterns cannot be predicted, stormwater quality devices placed in storm sewer systems must be able to withstand extreme events, and ensure that all pollutants previously captured are retained in the system.

In order to have confidence in a system’s performance under extreme conditions, independent validation of scour prevention is essential when examining different technologies. Lack of independent verification of scour prevention should make a designer wary of accepting any product’s performance claims.

8.3. Hydraulics

Full scale laboratory testing has been used to confirm the hydraulics of the Stormceptor System. Results of lab testing have been used to physically design the Stormceptor System and the sewer pipes entering and leaving the unit. Key benefits of Stormceptor are:

- Low head loss (typical k value of 1.3)
- Minimal inlet/outlet invert elevation drop across the structure
- Use as a bend structure
- Accommodates multiple inlets

The adaptability of the treatment device to the storm sewer design infrastructure can affect the overall performance and cost of the site.

8.4. Hydrology

Stormwater quality treatment technologies need to perform under varying climatic conditions. These can vary from long low intensity rainfall to short duration, high intensity storms. Since a treatment device is expected to perform under all these conditions, it makes sense that any system’s design should accommodate those conditions as well.

Long-term continuous simulation evaluates the performance of a technology under the varying conditions expected in the climate of the subject site. Single, peak event design does not provide this information and is not equivalent to long-term simulation. Designers should request long-term simulation performance to ensure the technology can meet the long-term water quality objective.

9. Testing

The Stormceptor System has been the most widely monitored stormwater treatment technology in the world. Performance verification and monitoring programs are completed to the strictest standards and integrity. Since its introduction in 1990, numerous independent field tests and studies detailing the effectiveness of the Stormceptor System have been completed.

- Coventry University, UK – 97% removal of oil, 83% removal of sand and 73% removal of peat
- National Water Research Institute, Canada, - scaled testing for the development of the Stormceptor System identifying both TSS removal and scour prevention.
- New Jersey TARP Program – full scale testing of an STC 900 demonstrating 75% TSS removal of particles from 1 to 1000 microns. Scour testing completed demonstrated that the system does not scour. The New Jersey Department of Environmental Protection was followed.
- City of Indianapolis – full scale testing of an STC 900 demonstrating over 80% TSS removal of particles from 50 microns to 300 microns at 130% of the unit's operating rate. Scour testing completed demonstrated that the system does not scour.
- Westwood Massachusetts (1997), demonstrated >80% TSS removal
- Como Park (1997), demonstrated 76% TSS removal
- Ontario MOE SWAMP Program – 57% removal of 1 to 25 micron particles
- Laval Quebec – 50% removal of 1 to 25 micron particles

10. Installation

The installation of the concrete Stormceptor should conform in general to state highway, or local specifications for the installation of manholes. Selected sections of a general specification that are applicable are summarized in the following sections.

10.1. Excavation

Excavation for the installation of the Stormceptor should conform to state highway, or local specifications. Topsoil removed during the excavation for the Stormceptor should be stockpiled in designated areas and should not be mixed with subsoil or other materials.

Topsoil stockpiles and the general site preparation for the installation of the Stormceptor should conform to state highway or local specifications.

The Stormceptor should not be installed on frozen ground. Excavation should extend a minimum of 12 inches (300 mm) from the precast concrete surfaces plus an allowance for shoring and bracing where required. If the bottom of the excavation provides an unsuitable foundation additional excavation may be required.

In areas with a high water table, continuous dewatering may be required to ensure that the excavation is stable and free of water.

10.2. Backfilling

Backfill material should conform to state highway or local specifications. Backfill material should be placed in uniform layers not exceeding 12 inches (300mm) in depth and compacted to state highway or local specifications.

11. Stormceptor Construction Sequence

The concrete Stormceptor is installed in sections in the following sequence:

1. Aggregate base
2. Base slab
3. Lower chamber sections
4. Upper chamber section with fiberglass insert
5. Connect inlet and outlet pipes
6. Assembly of fiberglass insert components (drop tee, riser pipe, oil cleanout port and orifice plate)
7. Remainder of upper chamber
8. Frame and access cover

The precast base should be placed level at the specified grade. The entire base should be in contact with the underlying compacted granular material. Subsequent sections, complete with joint seals, should be installed in accordance with the precast concrete manufacturer's recommendations.

Adjustment of the Stormceptor can be performed by lifting the upper sections free of the excavated area, re-leveling the base and re-installing the sections. Damaged sections and gaskets should be repaired or replaced as necessary. Once the Stormceptor has been constructed, any lift holes must be plugged with mortar.

12. Maintenance

12.1. Health and Safety

The Stormceptor System has been designed considering safety first. It is recommended that confined space entry protocols be followed if entry to the unit is required. In addition, the fiberglass insert has the following health and safety features:

- Designed to withstand the weight of personnel
- A safety grate is located over the 24 inch (600 mm) riser pipe opening
- Ladder rungs can be provided for entry into the unit, if required

12.2. Maintenance Procedures

Maintenance of the Stormceptor system is performed using vacuum trucks. No entry into the unit is required for maintenance (in most cases). The vacuum service industry is a well-established sector of the service industry that cleans underground tanks, sewers and catch basins. Costs to clean a Stormceptor will vary based on the size of unit and transportation distances.

The need for maintenance can be determined easily by inspecting the unit from the surface. The depth of oil in the unit can be determined by inserting a dipstick in the oil inspection/cleanout port.

Similarly, the depth of sediment can be measured from the surface without entry into the Stormceptor via a dipstick tube equipped with a ball valve. This tube would be inserted through the riser pipe. Maintenance should be performed once the sediment depth exceeds the guideline values provided in the Table 4.

Table 4. Sediment Depths Indicating Required Servicing*

Particle Size	Specific Gravity
Model	Sediment Depth inches (mm)
450i	8 (200)
900	8 (200)
1200	10 (250)
1800	15 (381)
2400	12 (300)
3600	17 (430)
4800	15 (380)
6000	18 (460)
7200	15 (381)
11000	17 (380)
13000	20 (500)
16000	17 (380)
* based on 15% of the Stormceptor unit's total storage	

Although annual servicing is recommended, the frequency of maintenance may need to be increased or reduced based on local conditions (i.e. if the unit is filling up with sediment more quickly than projected, maintenance may be required semi-annually; conversely once the site has stabilized maintenance may only be required every two or three years).

Oil is removed through the oil inspection/cleanout port and sediment is removed through the riser pipe. Alternatively oil could be removed from the 24 inches (600 mm) opening if water is removed from the lower chamber to lower the oil level below the drop pipes.

The following procedures should be taken when cleaning out Stormceptor:

1. Check for oil through the oil cleanout port
2. Remove any oil separately using a small portable pump
3. Decant the water from the unit to the sanitary sewer, if permitted by the local regulating authority, or into a separate containment tank
4. Remove the sludge from the bottom of the unit using the vacuum truck
5. Re-fill Stormceptor with water where required by the local jurisdiction

12.3. Submerged Stormceptor

Careful attention should be paid to maintenance of the Submerged Stormceptor System. In cases where the storm drain system is submerged, there is a requirement to plug both the inlet and outlet pipes to economically clean out the unit.

12.4. Hydrocarbon Spills

The Stormceptor is often installed in areas where the potential for spills is great. The Stormceptor System should be cleaned immediately after a spill occurs by a licensed liquid waste hauler.

12.5. Disposal

Requirements for the disposal of material from the Stormceptor System are similar to that of any other stormwater Best Management Practice (BMP) where permitted. Disposal options for the sediment may range from disposal in a sanitary trunk sewer upstream of a sewage treatment plant, to disposal in a sanitary landfill site. Petroleum waste products collected in the Stormceptor (free oil/chemical/fuel spills) should be removed by a licensed waste management company.

12.6. Oil Sheens

With a steady influx of water with high concentrations of oil, a sheen may be noticeable at the Stormceptor outlet. This may occur because a rainbow or sheen can be seen at very small oil concentrations (<10 mg/L). Stormceptor will remove over 98% of all free oil spills from storm sewer systems for dry weather or frequently occurring runoff events.

The appearance of a sheen at the outlet with high influent oil concentrations does not mean the unit is not working to this level of removal. In addition, if the influent oil is emulsified the Stormceptor will not be able to remove it. The Stormceptor is designed for free oil removal and not emulsified conditions.



SUPPORT

Drawings and specifications are available at www.ContechES.com.

Site-specific design support is available from our engineers.

©2020 Contech Engineered Solutions LLC, a QUIKRETE Company

Contech Engineered Solutions LLC provides site solutions for the civil engineering industry. Contech's portfolio includes bridges, drainage, sanitary sewer, stormwater, and earth stabilization products. For information, visit www.ContechES.com or call 800.338.1122

NOTHING IN THIS CATALOG SHOULD BE CONSTRUED AS A WARRANTY. APPLICATIONS SUGGESTED HEREIN ARE DESCRIBED ONLY TO HELP READERS MAKE THEIR OWN EVALUATIONS AND DECISIONS, AND ARE NEITHER GUARANTEES NOR WARRANTIES OF SUITABILITY FOR ANY APPLICATION. CONTECH MAKES NO WARRANTY WHATSOEVER, EXPRESS OR IMPLIED, RELATED TO THE APPLICATIONS, MATERIALS, COATINGS, OR PRODUCTS DISCUSSED HEREIN. ALL IMPLIED WARRANTIES OF MERCHANTABILITY AND ALL IMPLIED WARRANTIES OF FITNESS FOR ANY PARTICULAR PURPOSE ARE DISCLAIMED BY CONTECH. SEE CONTECH'S CONDITIONS OF SALE (AVAILABLE AT WWW.CONTECHES.COM/COS) FOR MORE INFORMATION.